

# RING TONGUE Non-insulated DIN 46234

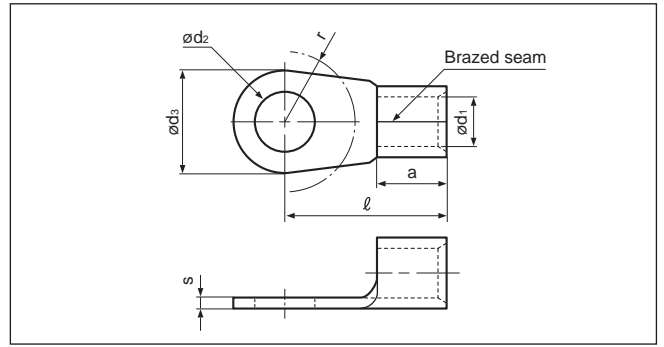

Applicable Wire mm <sup>2</sup>	Stud Size Metric	Part No.	Nominal Size DIN46234	Dimensions mm (in.)							Tool No.	Qty/box
				$\phi d_2$	$\phi d_3$	r	$\ell$	a	$\phi d_1$	s		
0.1 to <0.5	2	GS2-0.5	2-0.5	2.2 (.087)	5.0 (.197)	5.0 (.197)	9.8 (.386)	4.0 (.157)	1.0 (.039)	0.5 (.020)	WC-0510DIN	2,000
	2.5	GS2.5-0.5	2.5-0.5	2.7 (.106)	5.0 (.197)	5.0 (.197)	9.8 (.386)					
	3	GS3-0.5	3-0.5	3.2 (.126)	5.0 (.197)	5.0 (.197)	9.8 (.386)					
	3.5	GS3.5-0.5	3.5-0.5	3.7 (.146)	6.0 (.236)	5.0 (.197)	12.0 (.472)					
	4	GS4-0.5	4-0.5	4.3 (.169)	6.5 (.256)	6.0 (.236)	11.7 (.461)					
	5	GS5-0.5		5.3 (.209)	8.0 (.315)	6.5 (.256)	11.0 (.433)					
0.5 to 1	2	GS2-1		2.2 (.087)	6.0 (.236)	4.5 (.177)	11.0 (.433)	5.0 (.197)	1.6 (.063)	0.8 (.031)	WC-0510DIN	2,000
	2.5	GS2.5-1	2.5-1	2.7 (.106)	6.0 (.236)	4.5 (.177)	11.0 (.433)	5.0 (.197)				
	3	GS3-1	3-1	3.2 (.126)	6.0 (.236)	4.5 (.177)	11.0 (.433)	5.0 (.197)				
	3	GS3L-1		3.2 (.126)	6.5 (.256)	3.5 (.138)	8.0 (.315)	4.0 (.157)				
	3.5	GS3.5-1	3.5-1	3.7 (.146)	6.0 (.236)	4.5 (.177)	11.0 (.433)	5.0 (.197)				
	3.5	GS3.5L-1		3.7 (.146)	6.5 (.256)	3.5 (.138)	8.0 (.315)	4.0 (.157)				
	4	GS4S-1		4.3 (.169)	6.5 (.256)	3.5 (.138)	8.0 (.315)	4.0 (.157)				
	4	GS4M-1		4.3 (.169)	7.0 (.276)	5.5 (.217)	11.0 (.433)	5.0 (.197)				
	4	GS4-1	4-1	4.3 (.169)	8.0 (.315)	6.0 (.236)	12.0 (.472)	5.0 (.197)				
	5	GS5S-1		5.3 (.209)	8.0 (.315)	6.0 (.236)	12.0 (.472)	5.0 (.197)				
	5	GS5-1	5-1	5.3 (.209)	10.0 (.394)	6.5 (.256)	13.0 (.512)	5.0 (.197)				
	6	GS6S-1		6.5 (.256)	10.0 (.394)	6.5 (.256)	13.0 (.512)	5.0 (.197)				
	6	GS6-1		6.5 (.256)	12.0 (.472)	10.0 (.394)	17.0 (.669)	5.0 (.197)				
	8	GS8-1		8.4 (.331)	12.0 (.472)	10.0 (.394)	17.0 (.669)	5.0 (.197)				
>1 to 2.5	3	GS3-2.5	3-2.5	3.2 (.126)	6.0 (.236)	4.5 (.177)	11.0 (.433)	5.0 (.197)	2.3 (.091)	0.8 (.031)	WC-0510DIN	2,000
	3.5	GS3.5-2.5	3.5-2.5	3.7 (.146)	6.0 (.236)	4.5 (.177)	11.0 (.433)					
	3.5	GS3.5L-2.5		3.7 (.146)	6.8 (.268)	4.5 (.177)	11.0 (.433)					
	4	GS4S-2.5		4.3 (.169)	6.8 (.268)	4.5 (.177)	11.0 (.433)					
	4	GS4-2.5	4-2.5	4.3 (.169)	8.0 (.315)	6.0 (.236)	12.0 (.472)					
	5	GS5S-2.5		5.3 (.209)	8.0 (.315)	6.0 (.236)	12.0 (.472)					
	5	GS5-2.5	5-2.5	5.3 (.209)	10.0 (.394)	6.5 (.256)	14.0 (.551)					
	6	GS6S-2.5		6.5 (.256)	10.0 (.394)	6.5 (.256)	14.0 (.551)					
	6	GS6-2.5	6-2.5	6.5 (.256)	11.0 (.433)	7.5 (.295)	16.0 (.630)					
	8	GS8-2.5	8-2.5	8.4 (.331)	14.0 (.551)	10.0 (.394)	17.0 (.669)					
	10	GS10-2.5		10.5 (.413)	18.0 (.709)	12.0 (.472)	20.0 (.787)					
	12	GS12-2.5		13.0 (.512)	18.0 (.709)	12.0 (.472)	20.0 (.787)					
	16	GS16-2.5		17.0 (.669)	27.0(1.063)	16.0 (.630)	26.0(1.024)	4.8 (.189)				500
>2.5 to 6	4	GS4-6	4-6	4.3 (.169)	8.0 (.315)	6.0 (.236)	14.0 (.551)	6.0 (.236)	3.6 (.142)	1.0 (.039)	WC-0510DIN	1,000
	5	GS5-6	5-6	5.3 (.209)	10.0 (.394)	6.5 (.256)	15.0 (.591)					
	6	GS6-6	6-6	6.5 (.256)	11.0 (.433)	7.5 (.295)	16.0 (.630)					
	8	GS8-6	8-6	8.4 (.331)	14.0 (.551)	10.0 (.394)	19.0 (.748)					
	10	GS10-6	10-6	10.5 (.413)	18.0 (.709)	12.0 (.472)	21.0 (.827)					
	12	GS12-6		13.0 (.512)	18.0 (.709)	12.0 (.472)	21.0 (.827)					

Note:1) Contact J.S.T.(U.K.) Ltd for the above tools.  
 2) Delivery lead times may vary depending on the product. Contact JST for details.

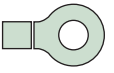
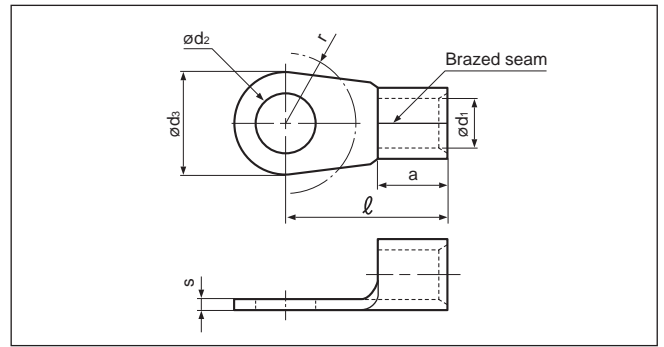
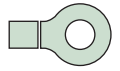
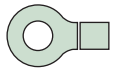

Applicable Wire mm <sup>2</sup>	Stud Size Metric	Part No.	Nominal Size DIN46234	Dimensions mm (in.)							Tool No.	Qty/box
				ød <sub>2</sub>	ød <sub>1</sub>	r	ℓ	a	ød <sub>1</sub>	s		
>6 to 10	4	GS4-10		4.3 (.169)	10.0 (.394)	6.5 (.256)	16.0 (.630)	8.0 (.315)	4.5 (.177)	1.1 (.043)	WC-0510DIN WC-1016DIN	500
	6	GS6-10	6-10	6.5 (.256)	11.0 (.433)	7.5 (.295)	17.0 (.669)					
	8	GS8-10	8-10	8.4 (.331)	14.0 (.551)	10.0 (.394)	20.0 (.787)					
	10	GS10-10	10-10	10.5 (.413)	18.0 (.709)	12.0 (.472)	21.0 (.827)					
	12	GS12-10	12-10	13.0 (.512)	22.0 (.866)	13.0 (.512)	23.0 (.906)					
>10 to 16	5	GS5-16	5-16	5.3 (.209)	11.0 (.433)	7.5 (.295)	20.0 (.787)	10.0 (.394)	5.8 (.228)	1.2 (.047)	WC-1016DIN	200
	6	GS6-16	6-16	6.5 (.256)	11.0 (.433)	7.5 (.295)	20.0 (.787)					
	8	GS8-16	8-16	8.4 (.331)	14.0 (.551)	10.0 (.394)	22.0 (.866)					
	10	GS10-16	10-16	10.5 (.413)	18.0 (.709)	12.0 (.472)	24.0 (.945)					
	12	GS12-16	12-16	13.0 (.512)	22.0 (.866)	13.0 (.512)	26.0(1.024)					
>16 to 25	5	GS5-25	5-25	5.3 (.209)	12.0 (.472)	7.5 (.295)	25.0 (.984)	11.0 (.433)	7.5 (.295)	1.5 (.059)	—	100
	6	GS6-25	6-25	6.5 (.256)	12.0 (.472)	7.5 (.295)	25.0 (.984)					
	8	GS8-25	8-25	8.4 (.331)	16.0 (.630)	10.0 (.394)	25.0 (.984)					
	10	GS10-25	10-25	10.5 (.413)	18.0 (.709)	12.0 (.472)	26.0(1.024)					
	12	GS12-25	12-25	13.0 (.512)	22.0 (.866)	13.0 (.512)	31.0(1.220)					
>25 to 35	6	GS6-35	6-35	6.5 (.256)	15.0 (.591)	10.0 (.394)	26.0(1.024)	12.0 (.472)	9.0 (.354)	1.6 (.063)	—	100
	8	GS8-35	8-35	8.4 (.331)	16.0 (.630)	10.0 (.394)	26.0(1.024)					
	10	GS10-35	10-35	10.5 (.413)	18.0 (.709)	12.0 (.472)	27.0(1.063)					
	12	GS12-35	12-35	13.0 (.512)	22.0 (.866)	13.0 (.512)	31.0(1.220)					
	16	GS16-35	16-35	17.0 (.669)	28.0(1.102)	16.0 (.630)	36.0(1.417)					
>35 to 50	6	GS6-50	6-50	6.5 (.256)	18.0 (.709)	12.0 (.472)	34.0(1.339)	16.0 (.630)	11.0 (.433)	1.8 (.071)	—	50
	8	GS8-50	8-50	8.4 (.331)	18.0 (.709)	12.0 (.472)	34.0(1.339)					
	10	GS10-50	10-50	10.5 (.413)	18.0 (.709)	12.0 (.472)	34.0(1.339)					
	12	GS12-50	12-50	13.0 (.512)	22.0 (.866)	13.0 (.512)	36.0(1.417)					
	16	GS16-50	16-50	17.0 (.669)	28.0(1.102)	16.0 (.630)	40.0(1.575)					
>50 to 70	6	GS6-70	6-70	6.5 (.256)	22.0 (.866)	13.0 (.512)	38.0(1.496)	18.0 (.709)	13.0 (.512)	2.0 (.079)	—	25
	8	GS8-70	8-70	8.4 (.331)	22.0 (.866)	13.0 (.512)	38.0(1.496)					
	10	GS10-70	10-70	10.5 (.413)	22.0 (.866)	13.0 (.512)	38.0(1.496)					
	12	GS12-70	12-70	13.0 (.512)	22.0 (.866)	13.0 (.512)	38.0(1.496)					
	16	GS16-70	16-70	17.0 (.669)	28.0(1.102)	16.0 (.630)	42.0(1.654)					
	20	GS20-70		21.0 (.827)	32.0(1.260)	18.0 (.709)	45.0(1.772)	19.0(.748)	13.3(.524)			

Note: 1) Contact J.S.T.(U.K.) Ltd for the above tools.

2) Delivery lead times may vary depending on the product. Contact JST for details.

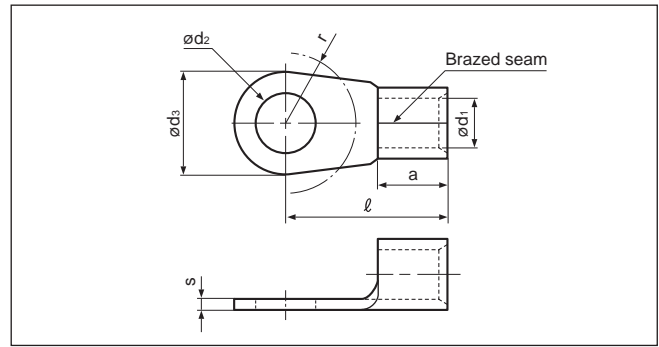
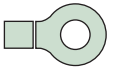

Applicable Wire mm <sup>2</sup>	Stud Size Metric	Part No.	Nominal Size DIN46234	Dimensions mm (in.)							Tool No.	Qty/box	
				$\phi d_2$	$\phi d_3$	r	$\ell$	a	$\phi d_1$	s			
>70 to 95	8	GS8-95	8-95	8.4 (.331)	24.0 (.945)	13.0 (.512)	42.0(1.654)	20.0 (.787)	15.0(.591)	2.5 (.098)	—	25	
	10	GS10-95	10-95	10.5 (.413)	24.0 (.945)	13.0 (.512)	42.0(1.654)						
	10	GS10L-95		10.5 (.413)	27.0(1.063)	14.0 (.551)	40.7(1.602)						
	12	GS12-95	12-95	13.0 (.512)	24.0 (.945)	13.0 (.512)	42.0(1.654)						
	12	GS12L-95		13.0 (.512)	27.0(1.063)	14.0 (.551)	40.7(1.602)						
	16	GS16-95	16-95	17.0 (.669)	28.0(1.102)	16.0 (.630)	44.0(1.732)						
	16	GS16LL-95		17.0 (.669)	32.0(1.260)	18.0 (.709)	52.0(2.047)						
	20	GS20L-95		21.0 (.827)	32.0(1.260)	18.0 (.709)	52.0(2.047)						
>95 to 120	8	GS8-120	8-120	8.4 (.331)	24.0 (.945)	13.0 (.512)	44.0(1.732)	22.0 (.866)	16.5 (.650)	3.0 (.118)	—	25	
	10	GS10-120	10-120	10.5 (.413)	24.0 (.945)	13.0 (.512)	44.0(1.732)						
	12	GS12-120	12-120	13.0 (.512)	24.0 (.945)	13.0 (.512)	44.0(1.732)						
	16	GS16-120	16-120	17.0 (.669)	28.0(1.102)	16.0 (.630)	48.0(1.890)						
	16	GS16S-120		17.0 (.669)	32.0(1.260)	20.0 (.787)	53.0(2.087)						
	20	GS20-120		21.0 (.827)	32.0(1.260)	25.0 (.984)	53.0(2.087)						
>120 to 150	10	GS10-150	10-150	10.5 (.413)	30.0(1.181)	16.0 (.630)	50.0(1.969)	24.0 (.946)	19.0 (.748)	3.2 (.126)	—	25	
	12	GS12-150	12-150	13.0 (.512)	30.0(1.181)	16.0 (.630)	50.0(1.969)						
	16	GS16-150	16-150	17.0 (.669)	30.0(1.181)	16.0 (.630)	50.0(1.969)						
	20	GS20-150		21.0 (.827)	36.0(1.417)	30.0(1.181)	63.0(2.480)						
>150 to 185	10	GS10-185	10-185	10.5 (.413)	36.0 (1.417)	16.0 (.630)	50.0 (1.969)	28.0 (1.102)	21.0 (.827)	3.5 (.138)	—	20	
	12	GS12-185	12-185	13.0 (.512)									
	16	GS16-185	16-185	17.0 (.669)									
>185 to 240	10	GS10-240	10-240	10.5 (.413)	38.0(1.496)	20.0 (.787)	56.0(2.205)	32.0(1.260)	23.5(.925)	4.0 (.157)	—	10	
	12	GS12-240	12-240	13.0 (.512)	38.0(1.496)	20.0 (.787)	56.0(2.205)						
	16	GS16-240	16-240	17.0 (.669)	38.0(1.496)	20.0 (.787)	56.0(2.205)						
>240 to 300	10	GS10-300		10.5 (.413)	50.5(1.988)		26.0(1.024)	69.0(2.717)	35.5 (1.398)	28.0 (1.102)	4.5 (.177)	—	5
	12	GS12L-300		13.0 (.512)			30.0(1.181)	80.5(3.169)					
	16	GS16-300		17.0 (.669)			26.0(1.024)	69.0(2.717)					
	22	GS22L-300		23.0 (.906)			30.0(1.181)	80.5(3.169)					

Note: 1) Contact J.S.T.(U.K.) Ltd for the above tools.  
 2) Delivery lead times may vary depending on the product. Contact JST for details.