

D.C. VOLUME AND BALANCE STEREO CONTROL CIRCUIT

The TCA730A is a monolithic integrated circuit for controlling volume and balance in stereo amplifiers by means of a d.c. voltage.

Features:

- physiological volume control
- balance control
- internal amplifier
- high-ohmic signals inputs
- internal supply voltage stabilization
- converter for the control voltage

QUICK REFERENCE DATA

Supply voltage (pin 8)	V_p	typ. 15 V
Supply current (pin 8)	I_p	typ. 35 mA
Input voltage range (r.m.s. value)	$V_{i(rms)}$	0,1 to 1,7 V
Nominal input voltage; $m = 1$ (r.m.s. value)	$V_{i(rms)}$	typ. 0,5 V
Input resistance	R_i	typ. 250 k Ω
Output voltage at nominal output power (r.m.s. value)	$V_{o(rms)}$	typ. 1 V
Volume control range	G_v	+20 to -80 dB
Channel balance	ΔG_v	typ. 1 dB
Balance control range	G_v	+5 to -7 dB
Total distortion at $V_{o(rms)} = 1$ V	d_{tot}	typ. 0,1 %
Channel separation	α	typ. 55 dB
Signal-to-noise ratio	S/N	typ. 67 dB
Frequency response (-1 dB)		20 Hz to 20 kHz
Volume control voltage range	V_{13-15}	2 to 9,5 V
Balance control voltage range	V_{12-15}	2,5 to 9,0 V
Supply voltage range (pin 8)	V_p	13,5 to 16,5 V
Ambient temperature range	T_{amb}	-30 to +80 °C

PACKAGE OUTLINE

16-lead DIL; plastic (SOT-38).

TCA730A

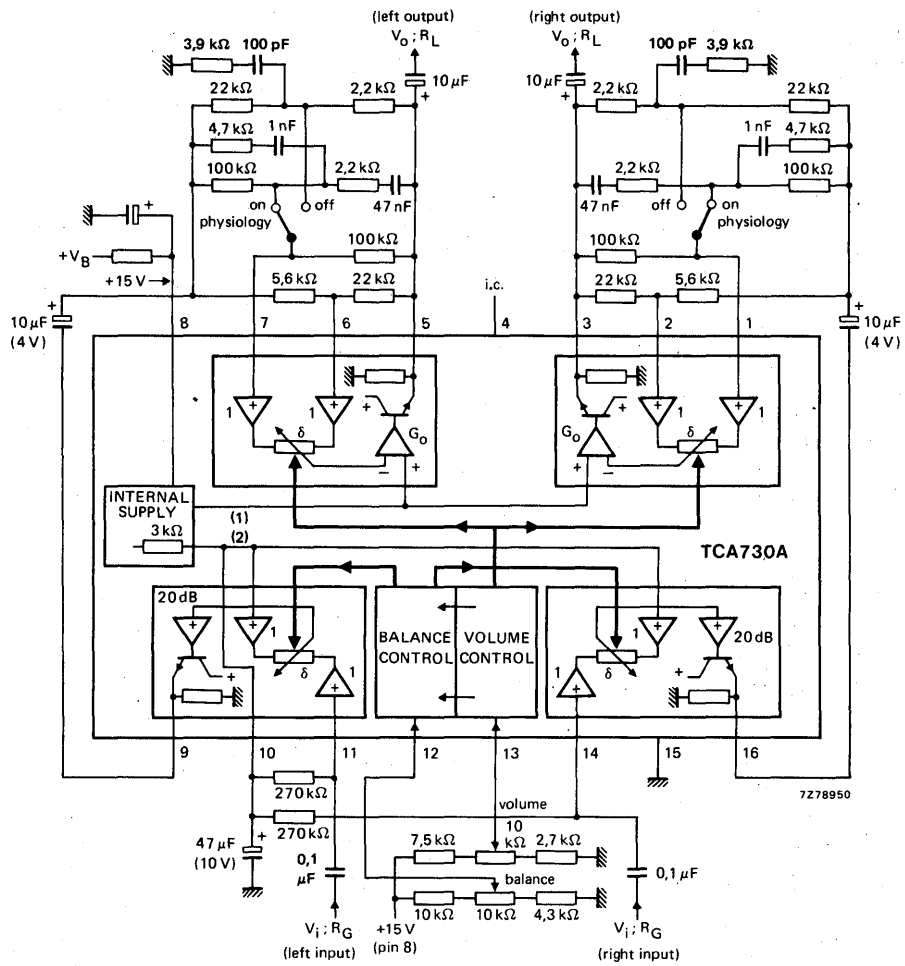

- (1) $6,6 V_{BE}; V_1 = 4,6 V$
- (2) $0,35 V_p + 0,65 V_{BE}; V_2 = 5,7 V.$

Fig. 1 Block diagram with external circuitry.

RATINGS

Limiting values in accordance with the Absolute Maximum System (IEC 134)

Supply voltage (pin 8)	V_p	max.	18 V
Input voltages	$V_{11-15}; V_{14-15}$	min.	0 V
		max.	V_p V
Control voltages	$V_{12-15}; V_{13-15}$	min.	-5 V
		max.	12 V
Total power dissipation	P_{tot}	max.	900 mW
Storage temperature range	T_{stg}		-55 to +150 °C
Operating ambient temperature range	T_{amb}		-30 to +80 °C

CHARACTERISTICS

$V_p = 15$ V; $T_{amb} = 25$ °C; measured in Fig. 1; balance control in mid-position ($V_{12-10} = 0$); physiology switch off; $f = 1$ kHz; $R_G = 22$ k Ω ; $R_L = 5,6$ k Ω ; unless otherwise specified.

Supply voltage range (pin 8)	V_p	13,5 to 16,5 V	
Supply current	I_p	typ.	35 mA
			25 to 43 mA
Control range			
Voltage gain range	G_v	0 to 20 dB	
Voltage gain at $V_{13-15} = 9,5$ V (0,63 V_p)	G_v	typ.	20 dB
			18 to 22 dB
Voltage attenuation range	G_v	0 to -80 dB	
Voltage attenuation at $V_{13-15} = 3$ V (0,2 V_p)	G_v	>	-75 dB
		typ.	-80 dB
Balance control range at $G_v = -10$ dB		+5 to -7 dB	

Control inputs

Recommended control voltage range			
volume	V_{13-15}	2 to 9,5 V	
balance	V_{12-15}	2,5 to 9,0 V	
Control voltage for $G_v = -10$ dB; $V_{12-10} = 0$	V_{13-15}	6,7 to 7,1 V*	
Control voltage for balance 0 dB; $V_{13-15} = 6,9$ V	V_{12-10}	typ. 0 \pm 0,2 V	
Internal supply voltage (0,35 V_p + 0,65 V_{BE})	V_{10-15}	typ.	5,9 V
			5,7 to 6,1 V
Output resistance (pin 10)	R_{o10}	typ.	3 k Ω
Control current			
volume ($V_{13-15} = 6,9$ V)	I_{13}	typ.	15 μ A
		<	50 μ A
balance ($V_{12-15} = 5,9$ V)	I_{12}	typ.	8 μ A
		<	25 μ A
Input resistance			
pin 13 (volume)	R_{i13}	typ.	500 k Ω
pin 12 (balance)	R_{i12}	typ.	600 k Ω

* Typical value 6,9 V.

TCA730A

CHARACTERISTICS (continued)

Signal processing

Frequency response (-1 dB)	f	20 Hz to 20 kHz
Input resistance; $R_{i11-10} = R_{i14-10} = 270 \text{ k}\Omega$ (pins 11; 14)	$R_{i11;14}$	typ. 250 $\text{k}\Omega$
Output resistance (pins 3; 5)	$R_{o3;5}$	typ. 10 Ω
Maximum input voltage; $V_{o(rms)} < 1 \text{ V}$; $d_{tot} = 0,7\%$ (r.m.s. value)	$V_{i(rms)}$	> 1,3 V typ. 1,7 V
Maximum output voltage; $V_{i(rms)} < 1 \text{ V}$; $d_{tot} = 0,7\%$ (r.m.s. value)	$V_{o(rms)}$	> 1,8 V typ. 2,0 V
Nominal input voltage; $m = 1$ (r.m.s. value)	$V_{i(rms)}$	typ. 0,5 V
Nominal output voltage at nominal output power (r.m.s. value)	$V_{o(rms)}$	typ. 1 V
Total distortion		
$V_{o(rms)} = 1 \text{ V}$; $G_v = \text{maximum}$	d_{tot}	typ. 0,07 % < 0,2 %
$V_{o(rms)} = 1 \text{ V}$; $V_{i(rms)} = 1 \text{ V}$	d_{tot}	typ. 0,2 %
$V_{o(rms)} = 50 \text{ mV}$; $V_{i(rms)} = 150 \text{ mV}$	d_{tot}	typ. 0,03 % < 0,1 %
$V_{o(rms)} = 50 \text{ mV}$; $V_{i(rms)} = 1 \text{ V}$	d_{tot}	typ. 0,2 %
Output noise voltage; $f = 20 \text{ Hz to } 20 \text{ kHz}$ signal plus noise voltage (r.m.s. value)		
$G_v = -60 \text{ dB}$	$V_{no(rms)}$	typ. 6 μV
$G_v = -10 \text{ dB}$	$V_{no(rms)}$	typ. 15 μV
$G_v = \text{maximum (+20 dB)}$	$V_{no(rms)}$	typ. 100 μV
noise voltage; weighted conform DIN45405 (peak value)		
$G_v = -60 \text{ dB}$	$V_{no(m)}$	typ. 15 μV
$G_v = -10 \text{ dB}$	$V_{no(m)}$	typ. 35 μV < 80 μV
$G_v = \text{maximum (+20 dB)}$	$V_{no(m)}$	typ. 230 μV < 350 μV
Channel separation; $G_v = \pm 20 \text{ dB}$; $V_i = V_o < 1 \text{ V}$		
$f = 250 \text{ Hz to } 12,5 \text{ kHz}$	α	> 52 dB typ. 53 dB
$f = 40 \text{ Hz to } 16 \text{ kHz}$	α	> 46 dB typ. 50 dB
Channel balance		
$G_v = +15 \text{ to } -50 \text{ dB}$	ΔG_v	typ. 1 dB < 2 dB
$G_v < 50 \text{ dB}$	ΔG_v	typ. 2 dB

Amplifier characteristics

Input resistance (pins 11 and 14)	$R_{i11;14}$	>	3 M Ω
D.C. output voltages (0,35 V _P – 1,35 V _{BE})	V ₃₋₁₅ ; V ₁₆₋₁₅	typ.	4,2 V
(6,6 V _{BE})	V ₃₋₁₅ ; V ₁₆₋₁₅	typ.	4,6 V
Quiescent input currents (pins 1,2,6,7,11,14)	I ₁ ; I ₂ ; I ₆ ; I ₇ ; I ₁₁ ; I ₁₄	<	0,5 μ A 2 μ A
Input resistance (pins 1,2,6 and 7) of physiology; without external circuitry	$R_{i1;2;6;7}$	>	1 M Ω
Internal load resistance at outputs (pins 3,5,9,16)	R ₃₋₁₅ ; R ₅₋₁₅ ; R ₉₋₁₅ ; R ₁₀₋₁₅	typ.	2 k Ω
Maximum gain; no load	G ₃₋₁ ; G ₃₋₂ ; G ₅₋₆ ; G ₅₋₇	typ.	> 40 dB 43 dB

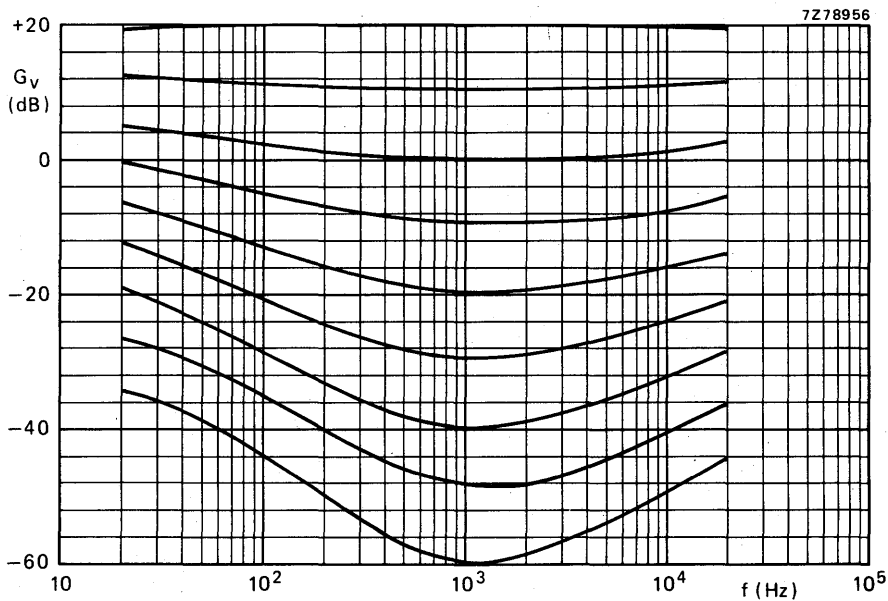

Fig. 2 Frequency response volume control with physiology.

TCA730A

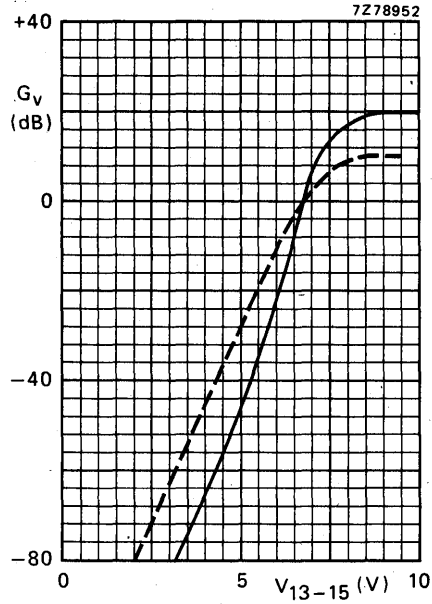

Fig. 3 Volume control curves; without physiology; balance = 0; $V_{12-10} = 0$.
 — $G_v \text{ tot}; G_v 5-11; G_v 3-14$
 - - - $G_v 9-11; G_v 16-14$

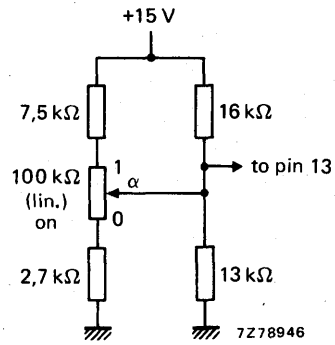
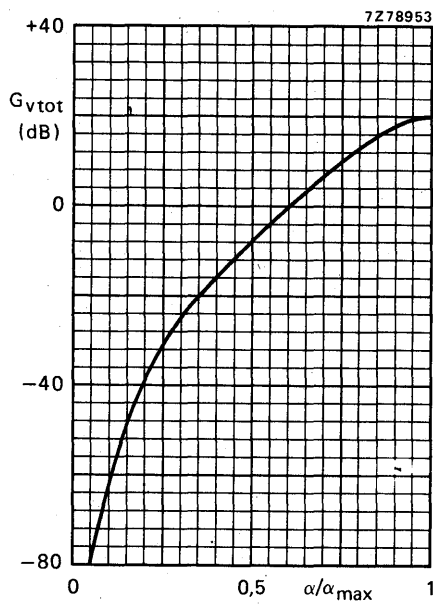

Fig. 4 Volume adjustment curve; balance = 0; $V_{12-10} = 0$.



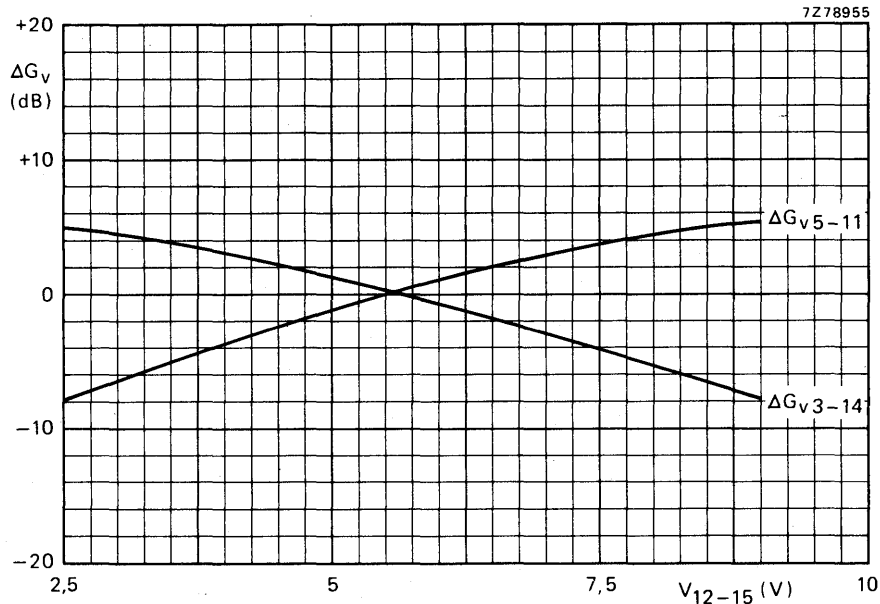

Fig. 5 Balance control curves; $G_{v \text{ tot}} = -10$ dB ($V_{13-15} = 6,9$ V); for balance = 0.

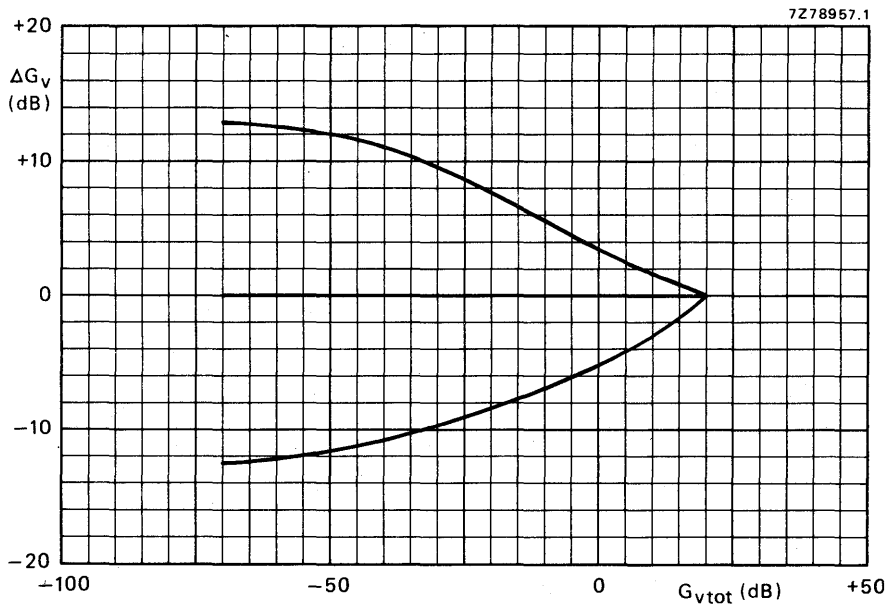
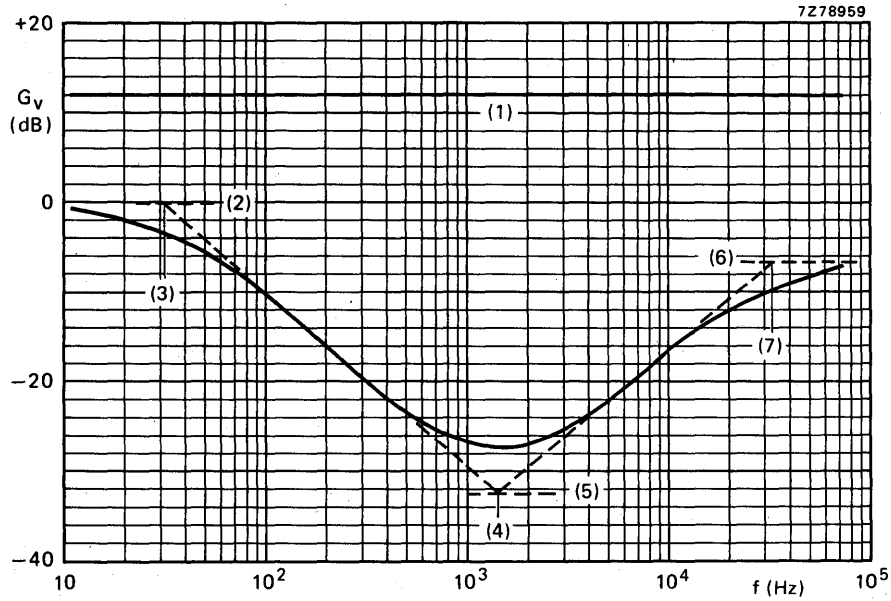

Fig. 6 Balance control range; $V_{12-15} = 2,5$ to $9,0$ V.



- (1) $G_v = R_2/R_1$
- (2) $G_v = R_42/R_31$
- (3) $G_v = 1/2\pi \cdot R_42 \cdot C_42$
- (4) $G_v = 1/2\pi \cdot R_41 \cdot C_31 = 1/2\pi \cdot R_31 \cdot C_31$
- (5) $G_v \approx R_41/R_32$
- (6) $G_v \approx R_41/R_32$
- (7) $G_v = 1/2\pi \cdot R_32 \cdot C_31$

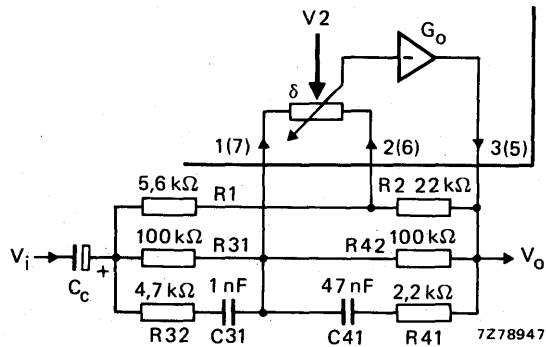

Fig. 7 Frequency response of the physiology part.

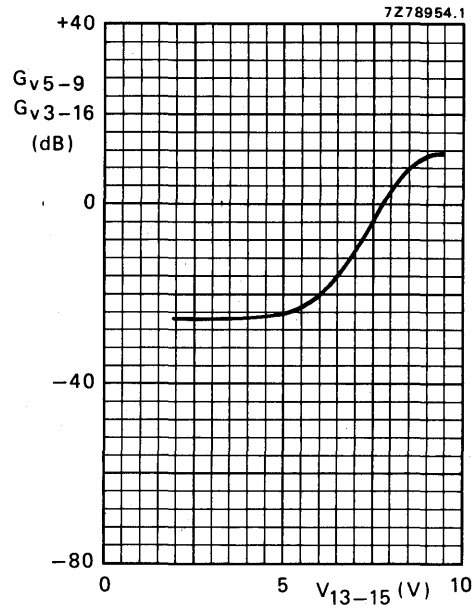

Fig. 8 Physiology control curve; $f = 1$ kHz; balance = 0; $V_{12-15} = 0$.



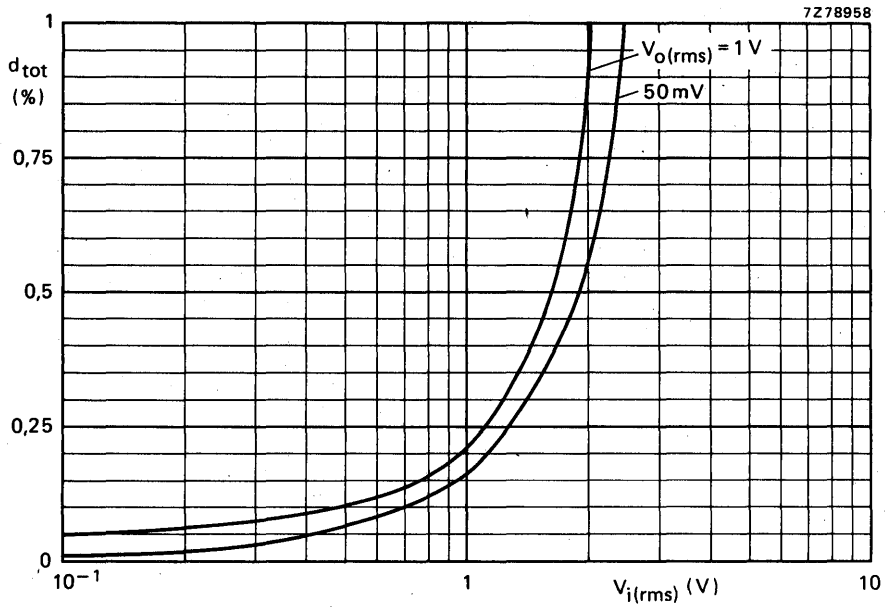

Fig. 9 Total distortion as a function of r.m.s. input voltage; $f = 1\text{ kHz}$; $R_L = 5,6\text{ k}\Omega$.

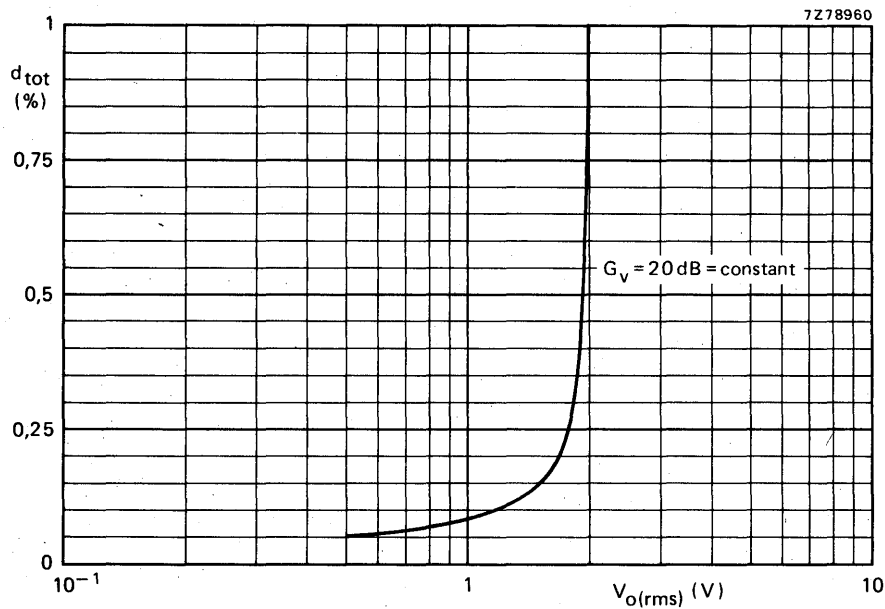

Fig. 10 Total distortion as a function of r.m.s. output voltage; $f = 1\text{ kHz}$; $R_L = 5,6\text{ k}\Omega$.

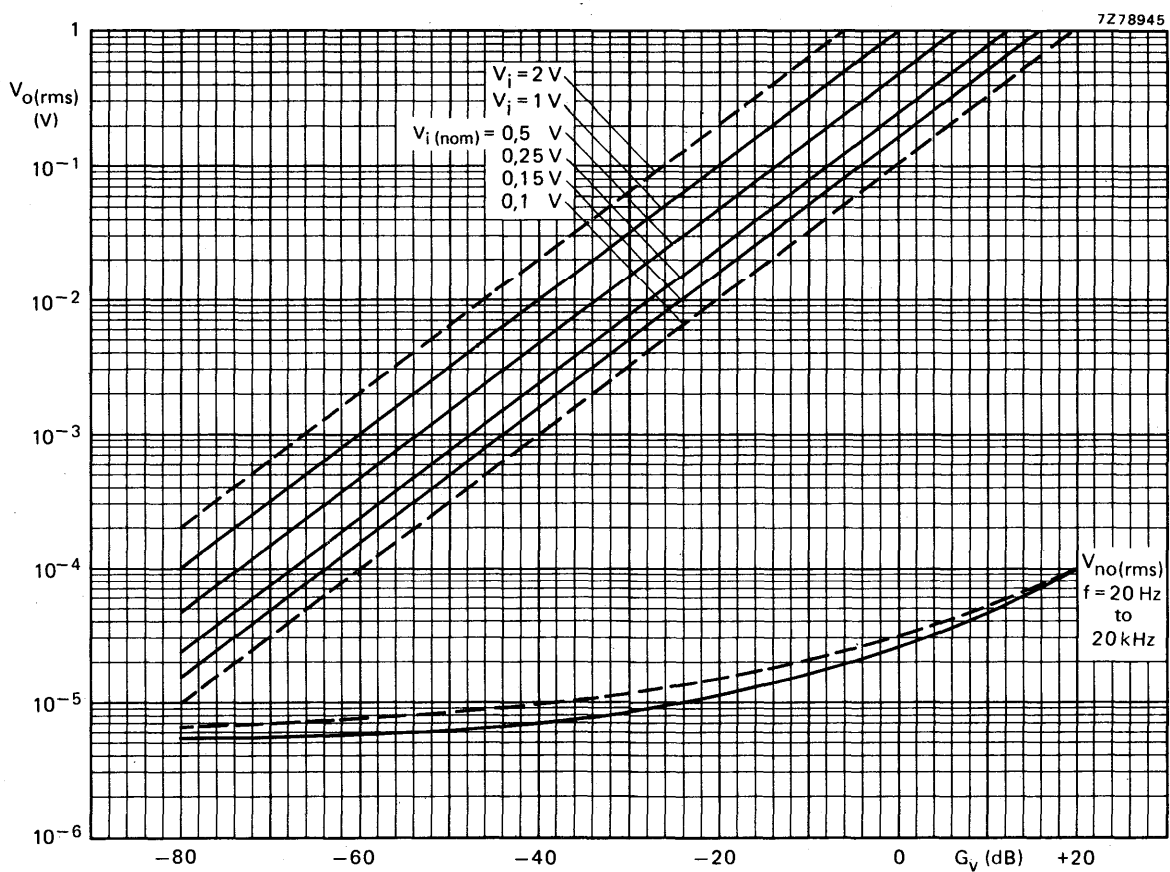
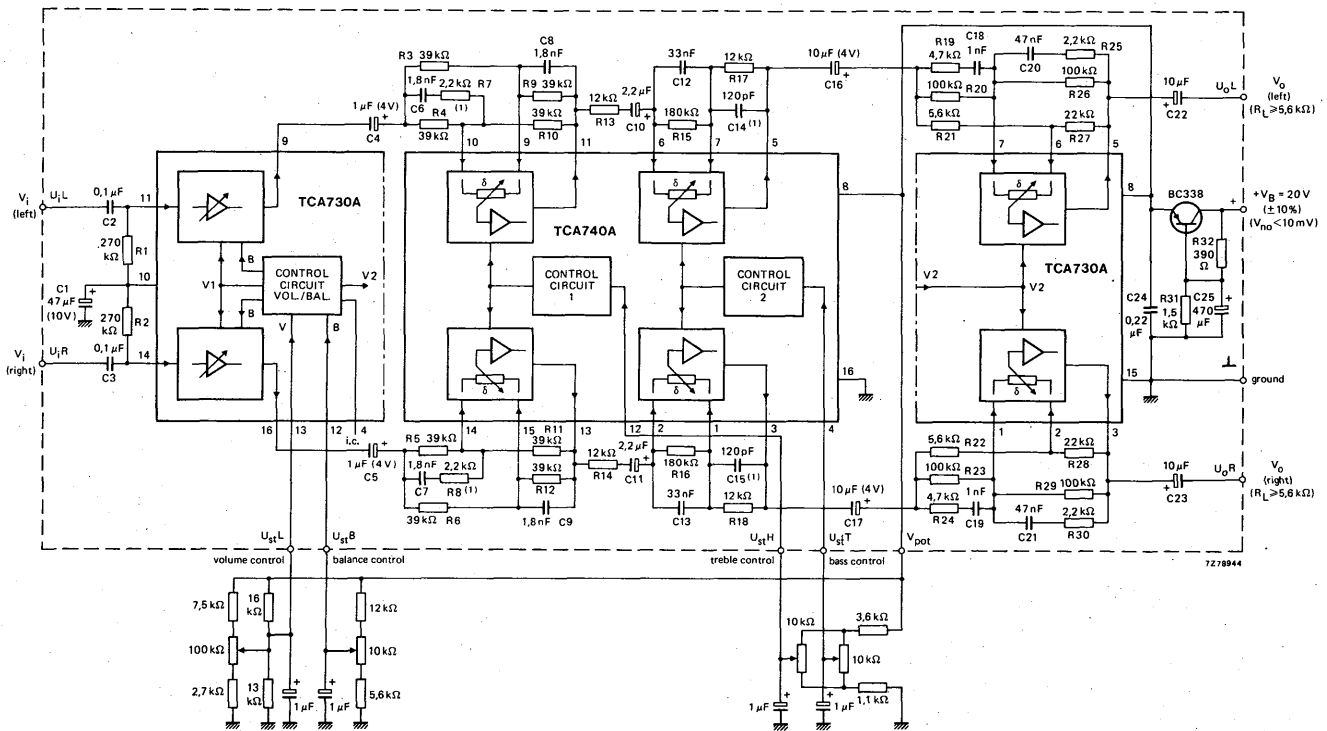

Fig. 11 The r.m.s. output voltage as a function of voltage gain; $P_{O(nom)}$ relative to $V_{O(rms)} = 1\text{ V}$.
— without physiological volume control; - - - with physiological volume control.



APPLICATION INFORMATION



(1) RC network for limiting treble boost (linear: f_{-3dB} = 100 kHz).

Fig. 12 Application diagram for TCA730A and TCA740A. For printed-circuit board see Fig. 13.

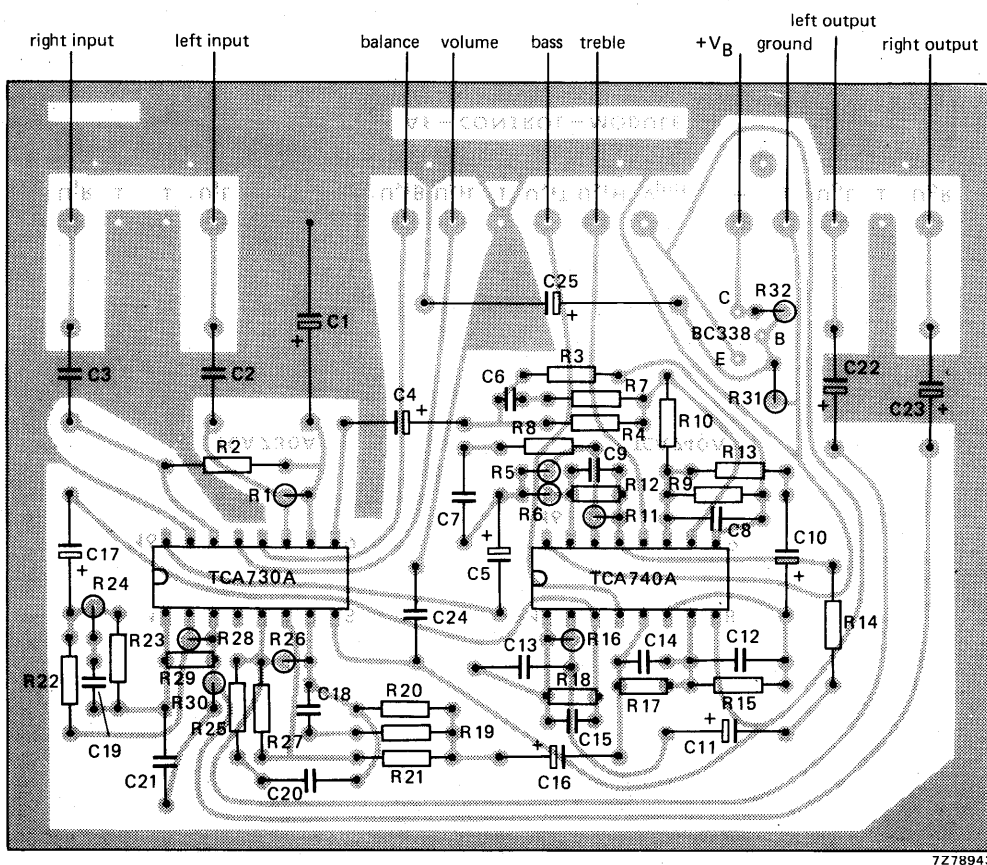
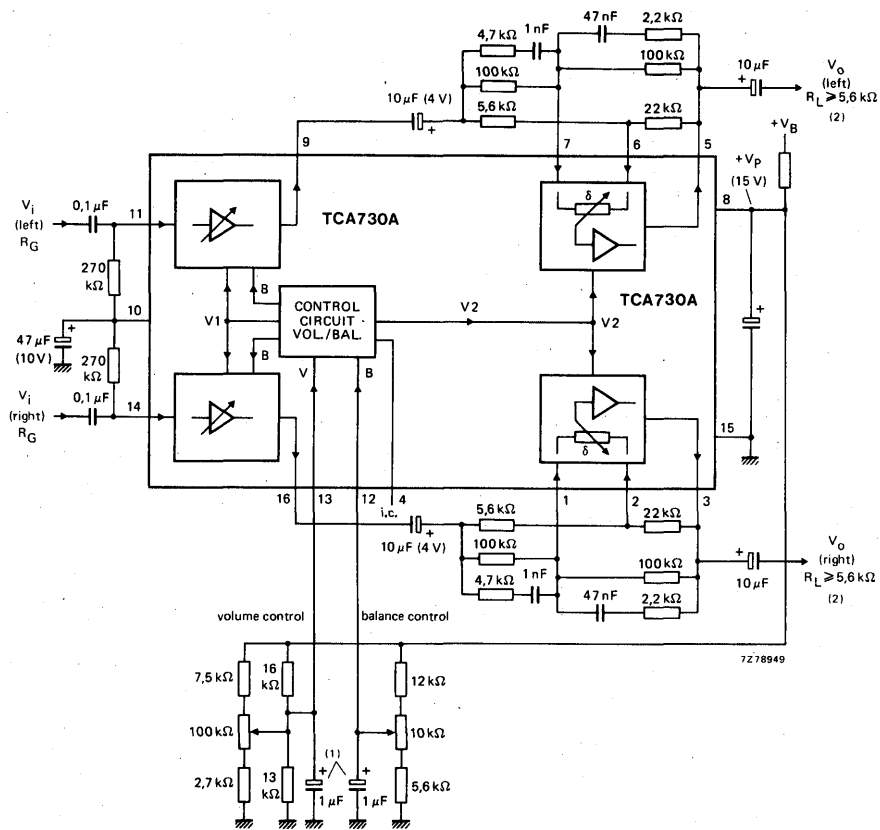

Fig. 13 Printed-circuit board component side, showing component layout; for circuit diagram see Fig. 12.



TCA730A

APPLICATION INFORMATION (continued)



- (1) C13-15 = C12-15 = 1 μF are intended for suppression of the noise when adjusting the mechanical potentiometers.
- (2) For rejecting noise, caused by switching on or off, corresponding muting switches can be used before or in the output power stage.

Fig. 14 Application example of TCA730A used for volume and balance control.