



## LINE OSCILLATOR COMBINATION FOR TV SET

- SYNC-PULSE SEPARATION
- OPTIONAL NOISE INVERSION
- GENERATION OF A LINE FREQUENCY VOLTAGE BY MEANS OF AN OSCILLATOR
- PHASE COMPARISON BETWEEN SYNC-PULSE AND THE OSCILLATOR WAVEFORM
- PHASE COMPARISON BETWEEN THE OSCILLATOR WAVEFORM AND THE MIDDLE OF THE LINE FLY-BACK PULSE
- AUTOMATIC SWITCHING OF THE VARIABLE TRANSCONDUCTANCE AND THE VARIABLE TIME CONSTANT TO ACHIEVE NOISE SUPPRESSION AND, BY SWITCHING OFF, POSSIBILITY OF TAPE-VIDEO-REGISTERED REPRODUCTION
- SHAPING AND AMPLIFICATION OF THE OSCILLATOR WAVEFORM TO OBTAIN PULSES FOR THE CONTROL OF DRIVING STAGES IN HORIZONTAL DEFLECTION CIRCUITS USING EITHER TRANSISTORS OR THYRISTORS

### DESCRIPTION

The line oscillator combination TBA920 is a monolithic integrated circuit intended for the horizontal deflection of the black and white and colour TV sets picture tube.

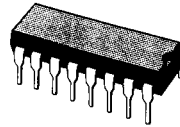

**TBA920-TBA920S**  
**DIP16**  
(Plastic Package)

### PIN CONNECTIONS

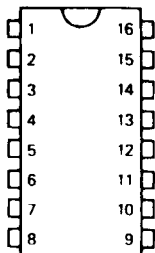

E88TBA920-01

- 1 - Positive supply
- 2 - Driver line stage pulse, driving an output stage
- 3 - Input control voltage for pulse width
- 4 - Phase discriminator output between fly-back pulse and oscillator
- 5 - Fly-back pulse input
- 6 - Synchro-pulse input
- 7 - Synchro pulse output
- 8 - Video signal input
- 9 - Noise gate input
- 10 - Switch emission-magnetoscope
- 11 - Time constant switch
- 12 - Oscillator control voltage loop
- 13 - Oscillator decoupling
- 14 - Tuning oscillator capacitor
- 15 - Oscillator control voltage
- 16 - Ground

BLOCK DIAGRAM

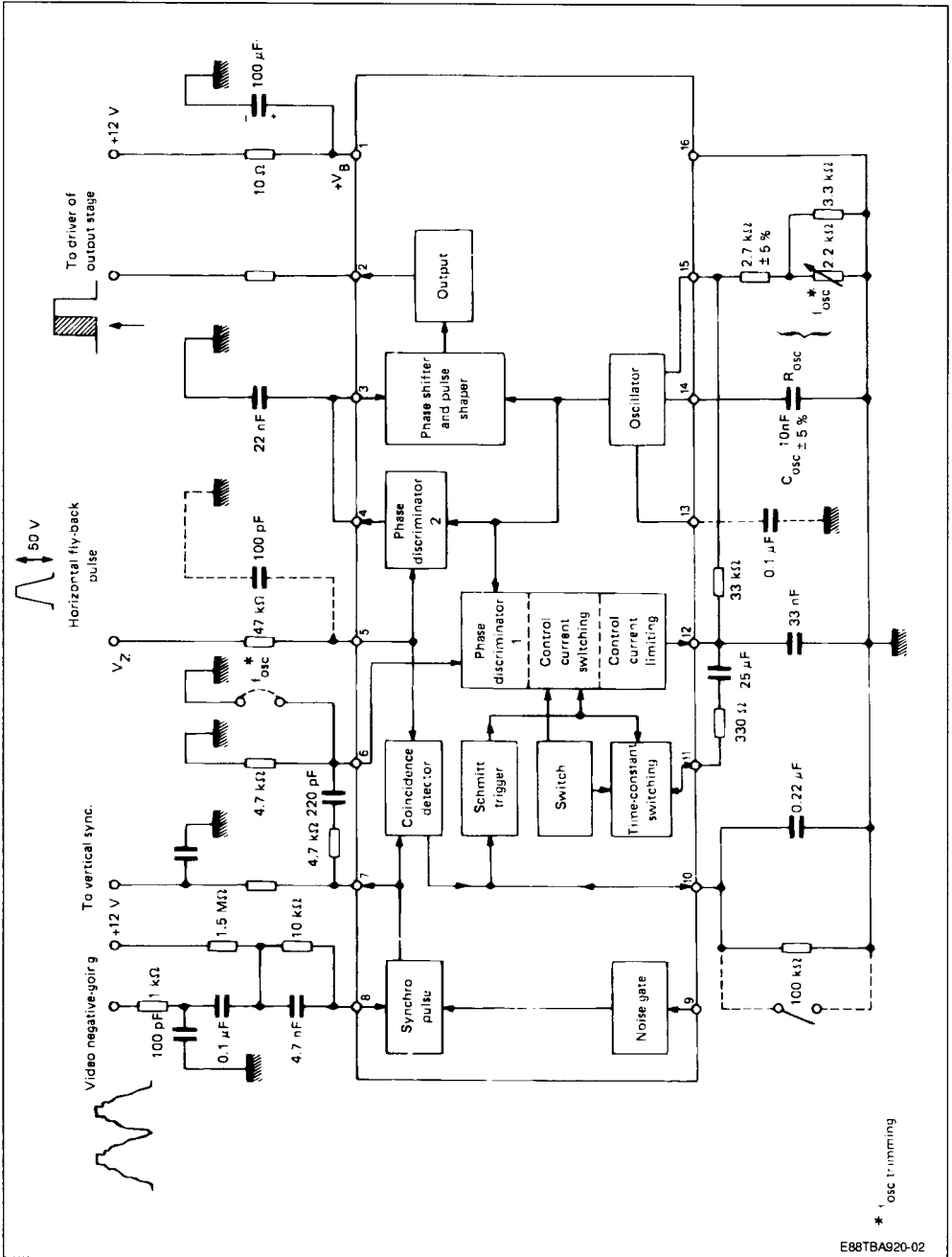

E88TBA920-02

## ABSOLUTE MAXIMUM RATINGS

Symbol	Parameter	Value	Unit
$V_{CC}$	Supply Voltage $V_{1-16}$	4 to 14	V
$P_{tot}$	Total Power Dissipation	600	mW
$T_{amb}$	Ambient Temperature	- 20 to 60	°C
$T_{stg}$	Storage Temperature	- 55 to 150	°C

## ELECTRICAL OPERATING CHARACTERISTICS

 $T_{amb} = 25\text{ °C}$ ,  $V_{CC} = 12\text{ V}$  (unless otherwise specified)

Symbol	Parameter	Min.	Typ.	Max.	Unit
$V_i$	Video Signal (pin 8) Input Voltage (positive synchro-pulse)	1	3	7	V
$I_i$	Input Current			0.2	mA
$I_i$	Fly-back (pin 5) Input Current	0.1	1	2	mA
$V_i$	Input Voltage		$\pm 0.8$		V
$Z_i$	Input Resistance		0.4		k $\Omega$
$I_i$	Noise Gate (pin 9) Input Current		20		$\mu$ A
$V_i$	Input Voltage		0.7		V
$V_o$	Synchro Pulse (pin 7) Output Voltage	9	10		V
$Z_o$	Output Impedance on Rise Time		50		$\Omega$
$Z_o$	Output Impedance on Fall Time		2.2		k $\Omega$
$I_o$	Line Amplifier Output Current (peak to peak)		25	200	mA
$V_o$	Output Voltage	9	10		V
$t_P$	Output Pulse Duration (adjust by $V_{3-16}$ )	12		32	$\mu$ s
	Fly-back Pulse Phase Control Delay accepted between output pulse and fly-back pulse	0		15	$\mu$ s
$I_o$	Output Current During Fly-back Pulse		$\pm 0.5$		mA
	Line Oscillator (no synchronized) for 625 Lines		15625 $\pm 5\%$		Hz
	At Supply Cut-off, without synchronized for 625 Lines		15625 $\pm 10\%$		Hz
	Phase Control between Oscillator and Synchro-pulse • with Emission Pull in Range		$\pm 1$		kHz
	Keep in Range		$\pm 1$		kHz
S	Sensibility • with Magnetoscope Keep in Range		3		kHz/ $\mu$ s
	Pull in Range		$\pm 350$		Hz
S	Sensibility		$\pm 350$		Hz
			$\pm 1$		kHz/ $\mu$ s
For TBA 9205 only					
$\Delta F_o$	Oscillator (pin 14) Oscillator Frequency Spread $R_{15-6} = 3.3\text{ k}\Omega$ $C_{14-16} = 10\text{ nF}$		$\leq 1.5$		%
$\Delta F_o$	Oscillator Frequency Range (figure 1 and 2)		$\pm 5$		%
$\Delta t$	Phase Position (pin 5-6) Phase spread between Front End Synch Pulse and Fly-back Pulse Center (figure 1)		$\leq \pm 0.4$		$\mu$ s

APPLICATION : EUROPEAN STANDARD 625 LINES

Figure 1.

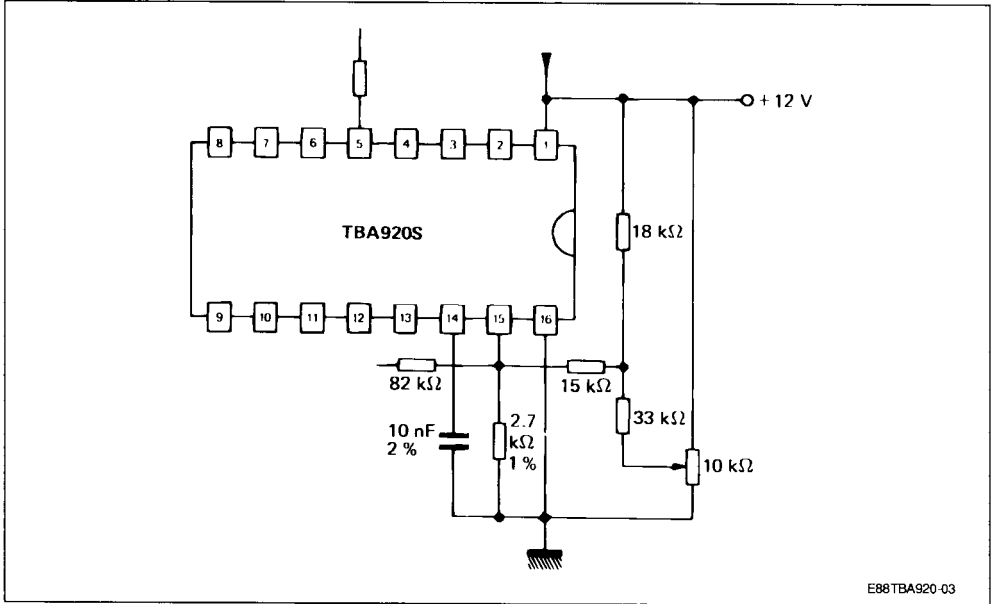
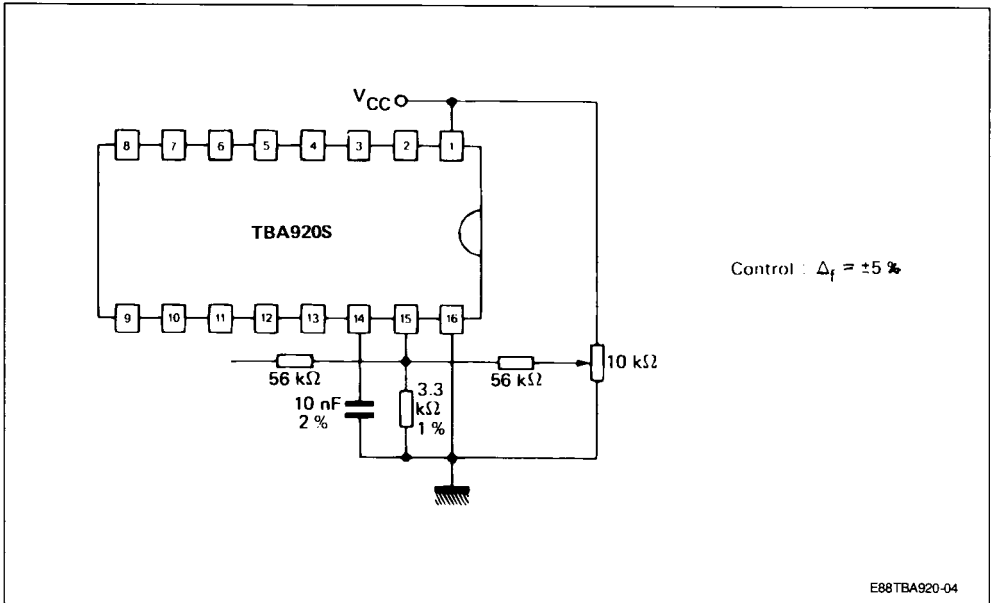

Figure 2.



PACKAGE MECHANICAL DATA

16 PINS – PLASTIC DIP

