

## 30W BTL×2CH AUDIO POWER AMPLIFIER

The thermal resistance  $\theta_{j-T}$  of TA8233AH package designed for low thermal resistance, has high efficiency of heat radiation.

The temperature rise of chip can be reduced, and the influence from the degradation of the features due to the temperature rise at the high output can also be reduced.

This stereo audio power IC, designed for car audio use, has two built-in channels to reduce the characteristic difference between L and R channels. It also contains output short detection circuit, output clip detection and various kind of protection.

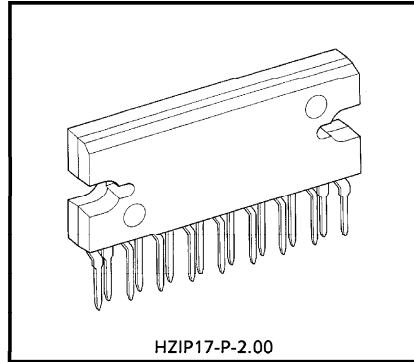

Weight : 9.8g (Typ.)

### FEATURES

- High power
  - :  $P_{OUT(1)} = 30W$  (Typ.) / Channel  
( $V_{CC} = 14.4V$ ,  $f = 1kHz$ ,  $THD = 10\%$ ,  $R_L = 2\Omega$ )
  - $P_{OUT(2)} = 26W$  (Typ.) / Channel  
( $V_{CC} = 13.2V$ ,  $f = 1kHz$ ,  $THD = 10\%$ ,  $R_L = 2\Omega$ )
  - $P_{OUT(3)} = 19W$  (Typ.) / Channel  
( $V_{CC} = 13.2V$ ,  $f = 1kHz$ ,  $THD = 10\%$ ,  $R_L = 4\Omega$ )
- Low thermal resistance :  $\theta_{j-T} = 1.5^\circ C / W$  (Infinite Heat Sink)
- Low distortion ratio :  $THD = 0.04\%$  (Typ.)  
( $V_{CC} = 13.2V$ ,  $f = 1kHz$ ,  $P_{OUT} = 1W$ ,  $R_L = 4\Omega$ ,  $G_V = 50dB$ )
- Low noise :  $V_{NO} = 0.30mV_{rms}$  (Typ.)  
( $V_{CC} = 13.2V$ ,  $R_L = 4\Omega$ ,  $G_V = 50dB$ ,  $R_g = 0\Omega$ ,  $BW = 20Hz \sim 20kHz$ )
- Built-in stand-by function : (With pin④ set at LOW, Power is turned OFF.)  $I_{SB} = 1\mu A$  (Typ.)
- Built-in output clip detection circuit : (pin① : Open Collector (Active Low))
- Built-in output short detection circuit : (pin⑨ : Open Collector (Active Low))
- Built-in various protection circuits : Thermal Shut Down, Over Voltage, Out  $\rightarrow$   $V_{CC}$  Short, Out  $\rightarrow$  GND Short and OUT-OUT Short.
- Operating supply voltage :  $V_{CC(opr)} = 9 \sim 18V$

● The information contained herein is presented only as a guide for the applications of our products. No responsibility is assumed by TOSHIBA CORPORATION for any infringements of intellectual property or other rights of the third parties which may result from its use. No license is granted by implication or otherwise under any intellectual property or other rights of TOSHIBA CORPORATION or others.

● TOSHIBA is continually working to improve the quality and the reliability of its products. Nevertheless, semiconductor devices in general can malfunction or fail due to their inherent electrical sensitivity and vulnerability to physical stress. It is the responsibility of the buyer, when utilizing TOSHIBA products, to observe standards of safety, and to avoid situations in which a malfunction or failure of a TOSHIBA product could cause loss of human life, bodily injury or damage to property.

In developing your designs, please ensure that TOSHIBA products are used within specified operating ranges as set forth in the most recent products specifications. Also, please keep in mind the precautions and conditions set forth in the TOSHIBA Semiconductor Reliability Handbook.

**BLOCK DIAGRAM**

TA8233AH ( $G_V = 50\text{dB}$ )

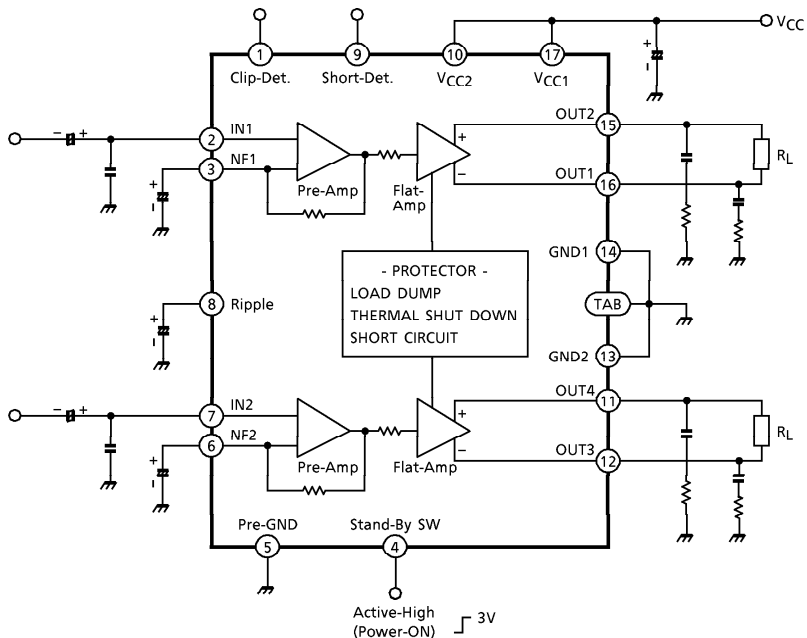

**CAUTION AND APPLICATION METHOD**

(Description is made only on the single channel.)

1. Voltage gain adjustment

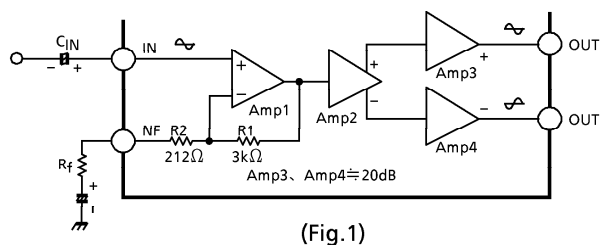

- Amp1 : Pre-Amp
- Amp2 : Phase Amp
- Amp3 : POWER Amp (Flat-Amp)
- Amp4 : POWER Amp (Flat-Amp)

This IC has the amplifier constructions as shown in Fig.1. The Pre-Amp (Amp 1) is provided to the primary stage, and the input voltage is amplified by the Flat Amps, Amp 3 and Amp 4 of each channel through the phase Amp (Amp 2). Since the input offset is prevented by Pre-Amp when  $V_{CC}$  is set to ON, this circuit can remarkably reduce the pop noise.

The total closed loop gain  $G_V$  of this IC can be obtained by expression below when the closed loop voltage gain of Amp 1 is  $G_{V1}$ .

$$G_{V1} = 20 \log \frac{R_1 + (R_f + R_2)}{R_f + R_2} \text{ (dB)} \dots\dots\dots (1)$$

The closed loop voltage gain of POWER Amp, Amp 3 and Amp 4 is fixed at  $G_{V3} \cong G_{V4} = 20\text{dB}$ . Therefore, the total closed circuit voltage gain  $G_V$  is obtained through BTL connection by the expression as below.

$$G_V = G_{V1} + G_{V3} + 6 \text{ (dB)} \dots\dots\dots (2)$$

For example, when  $R_f = 0\Omega$ ,  $G_V$  is obtained by the expressions (1) and (2) as below.

$$G_V \cong 24 + 20 + 6 = 50\text{dB}$$

The voltage gain is reduced when  $R_f$  is increased. (Fig.2)

With the voltage gain reduced, since (1) the oscillation stability is reduced, and (2) the pop noise changes when  $V_{CC}$  is set to ON, refer to the items 3 and 4.

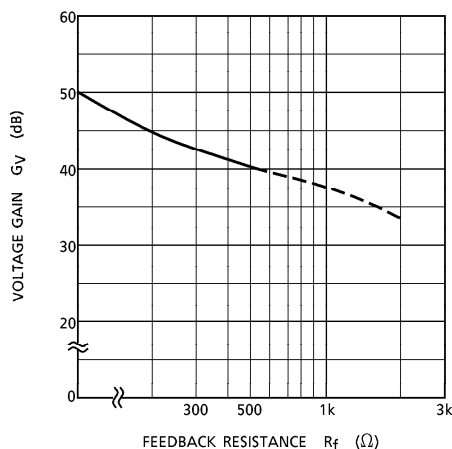

(Fig.2)

2. Stand-by SW function

By means of controlling pin④ (Stand-by terminal) to High and Low, the power supply can be set to ON and OFF. The threshold voltage of pin④ is set at 2.1V ( $3V_{BE}$ ), and the Power Supply current is about  $1\mu\text{A}$  (Typ.) at the stand-by state.

Control Voltage of pin④ :  $V(\text{SB})$

Stand-By	Power	$V(\text{SB})$ (V)
ON	OFF	0~2
OFF	ON	3~ $V_{CC}$

Adjustage of Stand-by SW

- (1) Since  $V_{CC}$  can directly be controlled to ON or OFF by the microcomputer, the switching relay can be omitted.
- (2) Since the control current is microscopic, the switching relay of small current capacity is satisfactory for switching

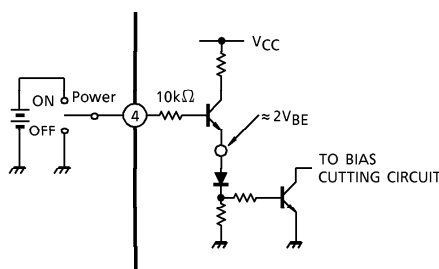

(Fig.3) With pin④ set to High, Power is turned ON

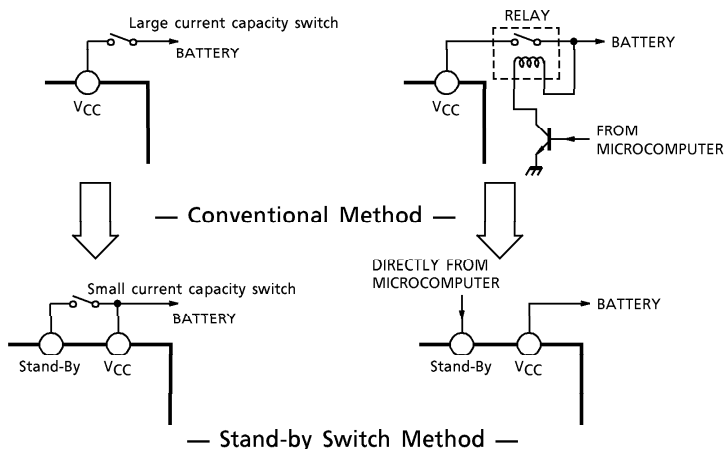

3. Preventive measure against oscillation

For preventing the oscillation, it is advisable to use C4, the condenser of polyester film having small characteristic fluctuation of the temperature and the frequency.

The condenser (C6) between input and GND is effective for preventing oscillation which is generated with a feedback signal from a output stage.

The resistance R to be series applied to C4 is effective for phase correction of high frequency, and improves the oscillation allowance.

- (1) Voltage gain to be used ( $G_V$  Setting)
- (2) Capacity value of condenser
- (3) Kind of condenser
- (4) Layout of printed board

In case of its use with the voltage gain  $G_V$  reduced or with the feedback amount increased, care must be taken because the phase-inversion is caused by the high frequency resulting in making the oscillation liable generated.

4. Adjustment of output offset (When the power supply turn on)

As this IC is constructed with DC circuit on the Pre-Amp stage, it is necessary to lower a input offset or output offset by agreement with the each leading edge time constant of the input voltage in the Pre-Amp stage and NF terminal voltage.

Concretely, monitor the output DC voltage and vary the capacity value in input condenser and NF condenser (See Fig.4)

(Reference) In case of setting the condition ( $G_V = 40\text{dB}$ ) with  $R_f = 470\Omega$

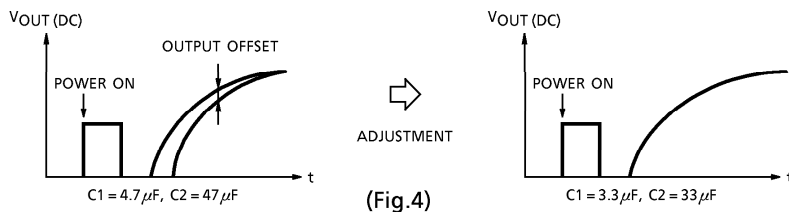

5. Output clip detection function (pin①)

The output clip detection terminal of pin① has the open collector output structure on chip as shown in Fig.5. In case that the output waveform is clipping, the clip detection circuit is operated and NPN Tr. is turned on.

It is possible to improve the tone quality with the current of flowing into pin① and with controlling the volume, tone control circuit through L.P.F smoothing circuit as shown in Fig.5. In case of being unused this function, use this IC as open connection on pin①.

(Application)

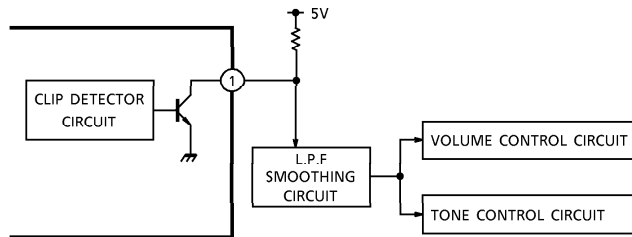

pin① : Open Collector Output (Active Low)

(Fig.5)

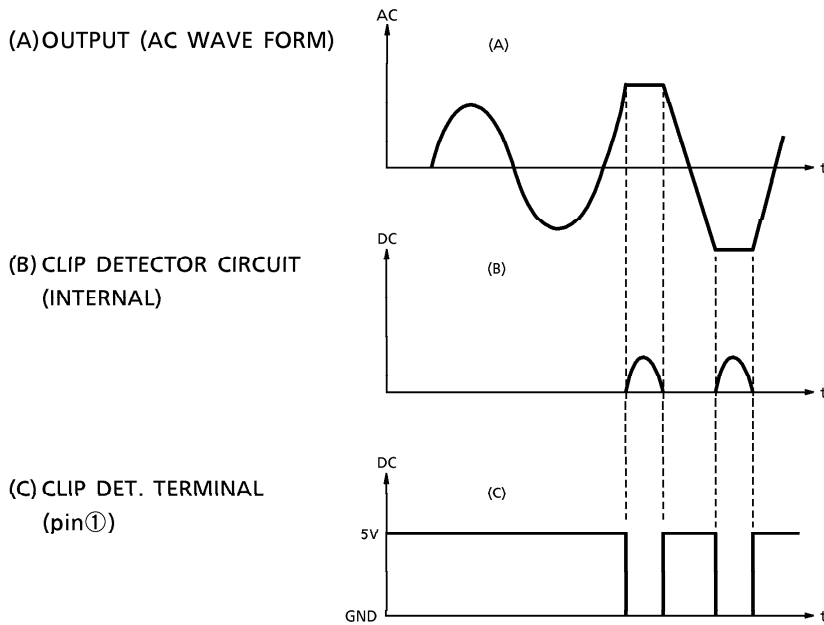

6. Output to  $V_{CC}$ , output to gnd short detection function (pin⑨)

The Output Short Detection Terminal of pin⑨ has open collector output structure on chip as shown in Fig.6.

In unusual case that output terminal of Power Amp. is condition of output to  $V_{CC}$  or output to GND short, it is possible to protect all the system of apparatus as well as power IC protection.

In case of being unused this function, use this IC as open-connection on pin⑨.

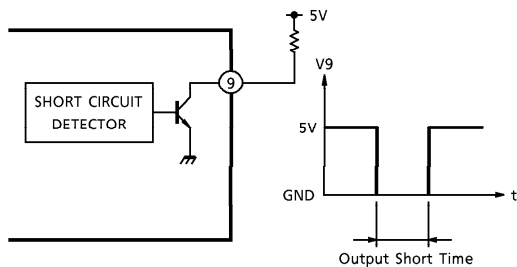

pin⑨ : Open Collector Output (Active Low)

(Fig.6)

(Application)

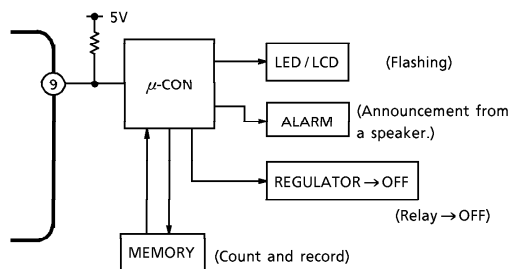

(Fig.7)

7. Rapid ripple discharging circuit at the time of  $V_{CC}$  OFF

This circuit is effective in such a mode where the  $V_{CC}$  and the stand-by terminals become high or Low simultaneously ; for instance, for a pop noise produced when the power is turned ON or OFF repeatedly by operating the ignition key.

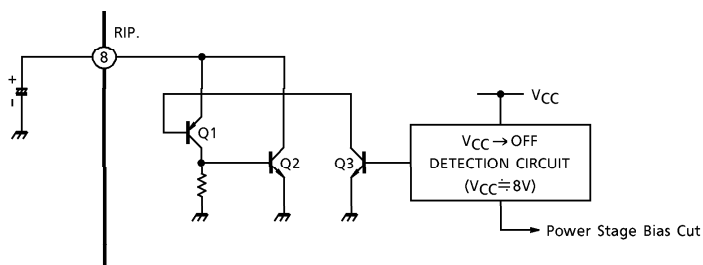

(Fig.8)

When  $V_{CC}$  is OFF, this detection circuit detect  $V_{CC} \doteq 8V$  internally on IC.

(1) The power stage bias circuit is cut.

(2) pin⑧ : Ripple Capacitor is rapidly discharged by turning Q3 ON and then Q1 and Q2 ON.

(Precaution 1)

When the stand-by terminal was put to the low level after the ripple rapid discharging circuit was operated ( $V_{CC} \approx 8V$ ) at the time when  $V_{CC}$  was turned OFF, a pop noise may be generated. Therefore,  $V_{CC}$  which makes the Stand-by terminal low shall be set at 8V or above so that (1) the Stand-by terminal is put at the low level and (2) the ripple rapid discharging circuit is turned ON when  $V_{CC}$  is turned OFF (in order of (1) and (2)). An example of application is shown in Fig.9.

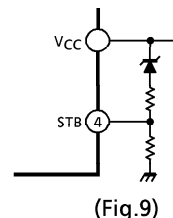

(Precaution 2)

If the falling time constant of the  $V_{CC}$  line is large (the fall is gentle), the pop noise may become worse.

In this case, it is possible to prevent the pop noise from becoming worse by reducing the ability of "Ripple Rapid Discharging Circuit at the time of  $V_{CC}$  OFF" according to the increase of the capacity of ripple capacitor of pin⑧.

However, it shall be kept in mind that the time for turning the power ON becomes longer as the result of this method.

8. External part list and description

SYM-BOL	RECOMMENDED VALUE	FEATURE	INFLUENCE		REMARKS
			SMALLER THAN RECOMMENDED VALUE	LARGER THAN RECOMMENDED VALUE	
C1	4.7 $\mu$ F	DC blocking	Related to pop noise at $V_{CC} \rightarrow$ ON.		Related to gain. Refer to item 4.
C2	47 $\mu$ F	Feedback condenser	Related to pop noise at $V_{CC} \rightarrow$ ON. Determination of low cut-off frequency $C2 = \frac{1}{2\pi \cdot f_L \cdot R_f}$		
C3	220 $\mu$ F	Ripple reduction	Time constant is small at $V_{CC} \rightarrow$ ON or OFF.	Time constant is Large at $V_{CC} \rightarrow$ ON or OFF.	
C4	0.12 $\mu$ F	Oscillation prevention	Made liable to oscillate.	Oscillation allowance	Refer to item 3.
C5	1000 $\mu$ F	Ripple filter	For filtering power supply hum and ripple. Large at using AC rectified power supply. Small at using DC power supply.		
C6	1000pF	Oscillation prevention	Oscillation allowance improved. Noise Reduction		Refer to item 3.

**MAXIMUM RATINGS** (Ta = 25°C)

CHARACTERISTIC	SYMBOL	RATING	UNIT
Peak Supply Voltage (0.2s)	V <sub>CC (surge)</sub>	50	V
DC Supply Voltage	V <sub>CC (DC)</sub>	25	V
Operating Supply Voltage	V <sub>CC (opr)</sub>	18	V
Output Current (Peak)	I <sub>O (peak)</sub>	9	A
Power Dissipation	P <sub>D</sub>	50	W
Operating Temperature	T <sub>opr</sub>	-30~85	°C
Storage Temperature	T <sub>stg</sub>	-55~150	°C

**ELECTRICAL CHARACTERISTICS** (Unless otherwise specified, V<sub>CC</sub> = 13.2V, R<sub>L</sub> = 4Ω, f = 1kHz, Ta = 25°C)

CHARACTERISTIC	SYMBOL	TEST CIRCUIT	TEST CONDITION	MIN.	TYP.	MAX.	UNIT
Quiescent Supply Current	I <sub>CCO</sub>	—	V <sub>IN</sub> = 0	—	120	250	mA
Output Power	P <sub>OUT (1)</sub>	—	V <sub>CC</sub> = 14.4V, R <sub>L</sub> = 2Ω THD = 10%	—	30	—	W
	P <sub>OUT (2)</sub>	—	R <sub>L</sub> = 2Ω, THD = 10%	17	26	—	
	P <sub>OUT (3)</sub>	—	THD = 10%	16	19	—	
Total Harmonic Distortion Ratio	THD	—	P <sub>OUT</sub> = 1W	—	0.04	0.4	%
Voltage Gain	G <sub>V</sub>	—	—	48	50	52	dB
Voltage Gain Ratio	ΔG <sub>V</sub>	—	—	-1.0	0	1.0	dB
Output Noise Voltage	V <sub>NO</sub>	—	R <sub>g</sub> = 0Ω, BW = 20Hz~20kHz	—	0.3	0.7	mV <sub>rms</sub>
Ripple Rejection Ratio	R.R.	—	f <sub>ripple</sub> = 100Hz, R <sub>g</sub> = 600Ω	40	54	—	dB
Input Resistance	R <sub>IN</sub>	—	—	—	30	—	kΩ
Output Offset Voltage	V <sub>offset</sub>	—	V <sub>IN</sub> = 0	-100	0	100	mV
Current at Stand-by State	I <sub>SB</sub>	—	—	—	1	10	μA
Cross Talk	C.T.	—	R <sub>g</sub> = 600Ω V <sub>OUT</sub> = 0.775V <sub>rms</sub> (0dBm)	—	60	—	dB
Pin④ Control Voltage	V <sub>SB</sub>	—	Stand-By → OFF (Power → ON)	2.5	—	V <sub>CC</sub>	V
Pin① (CLIP DET) Saturation Voltage	V <sub>sat ①</sub>	—	I <sub>C</sub> = 1mA	—	100	—	mV
Pin⑨ (SHORT DET) Saturation Voltage	V <sub>sat ⑨</sub>	—	I <sub>C</sub> = 1mA	—	100	—	mV

V<sub>sat ①</sub>, V<sub>sat ⑨</sub> Test Circuit

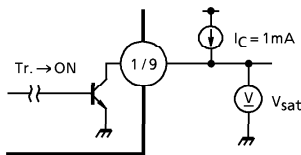



**TEST CIRCUIT**

TA8233AH ( $G_V = 50\text{dB}$ )

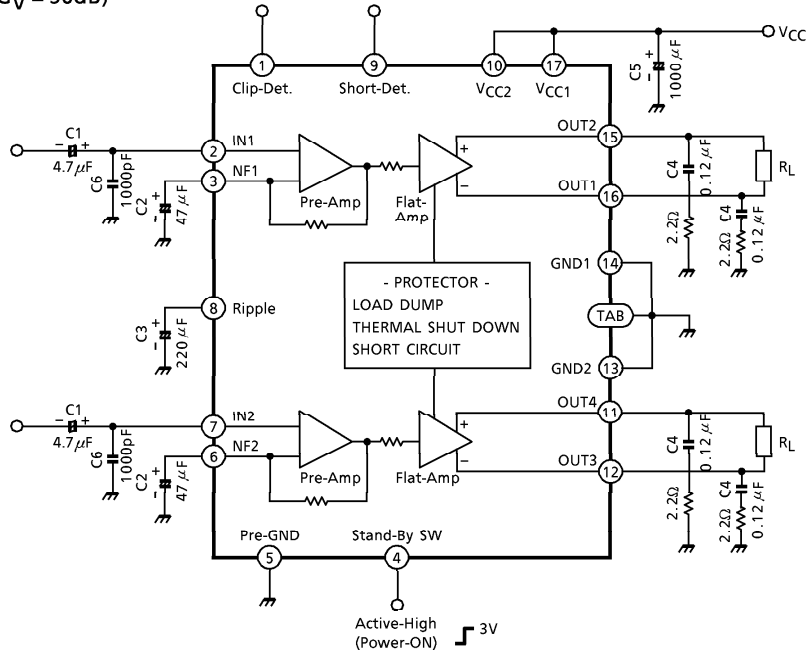

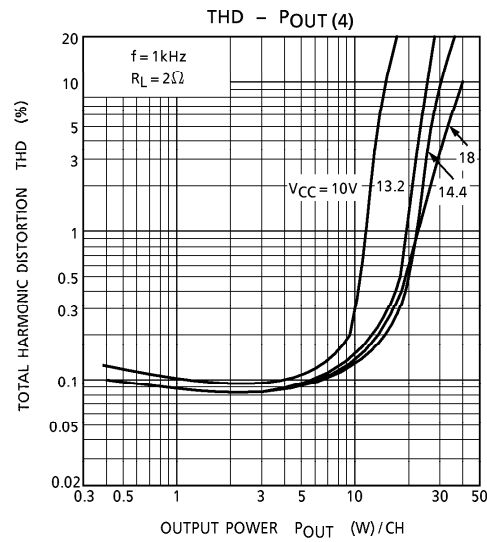
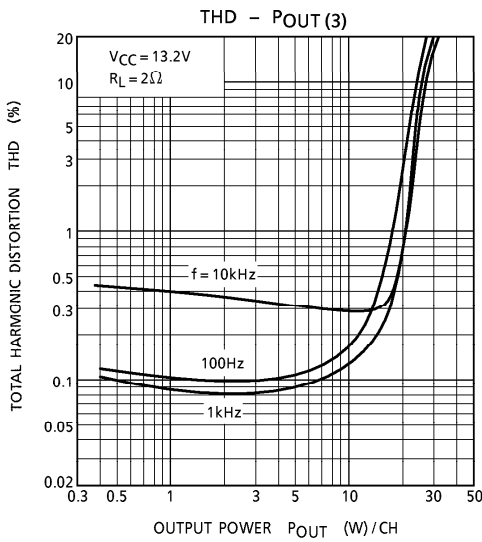
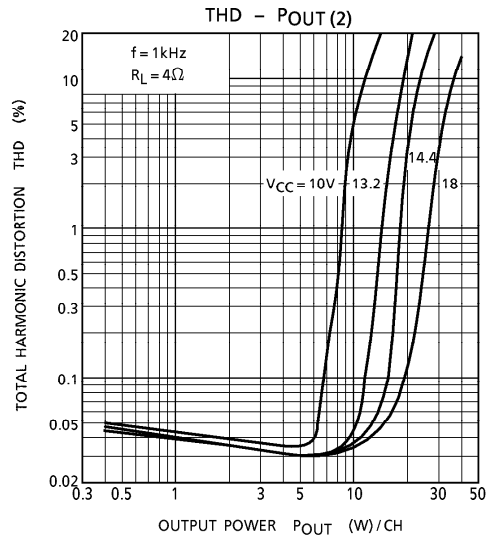
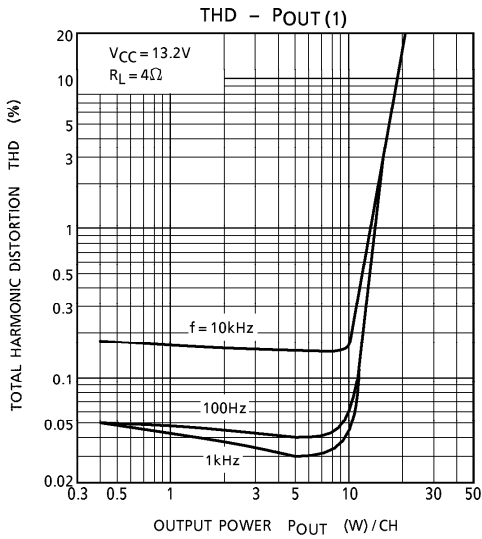

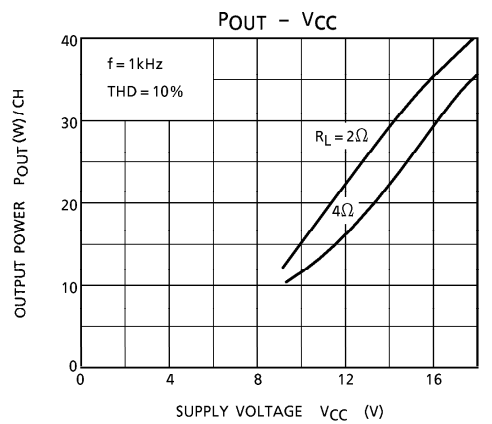
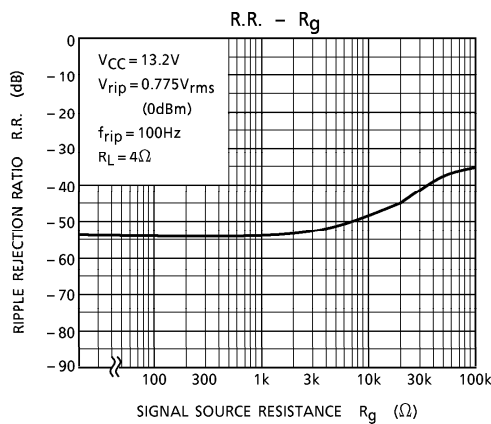
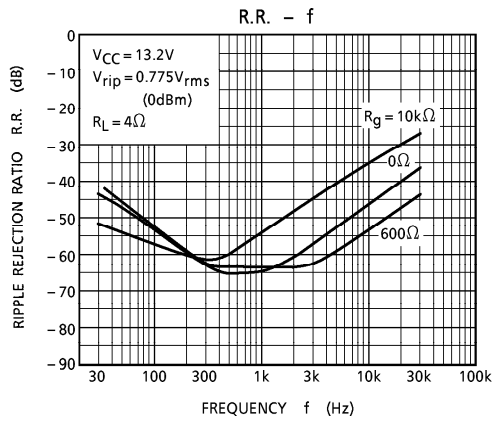
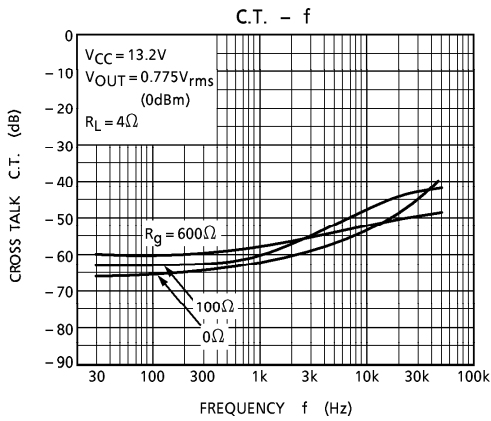
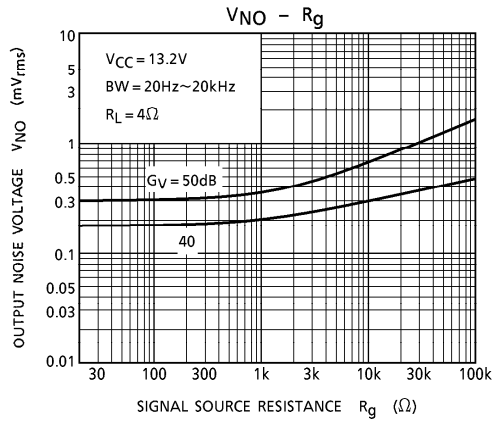
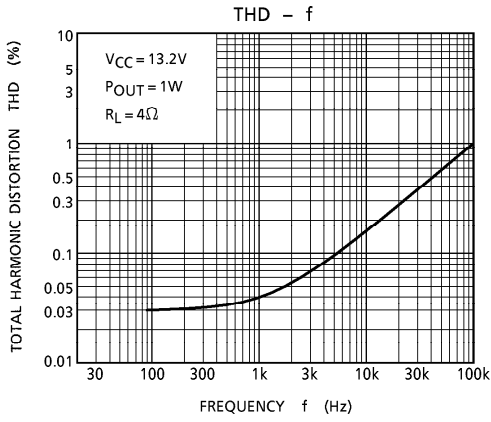

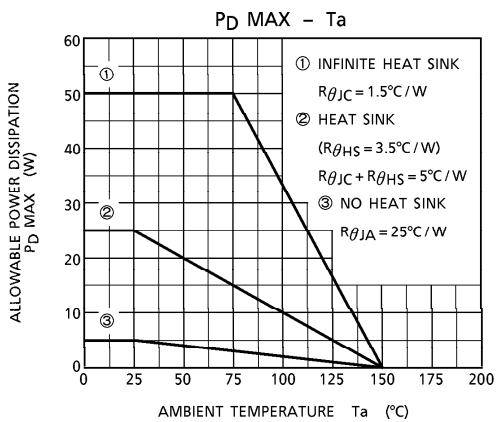
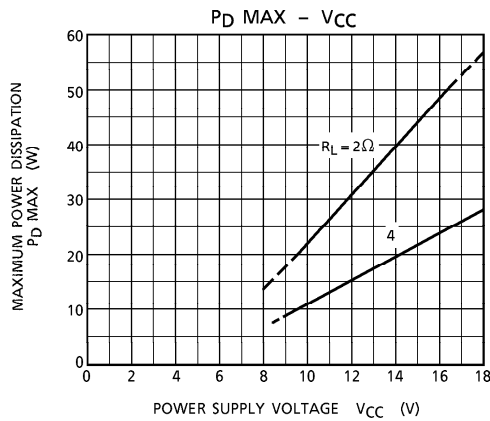
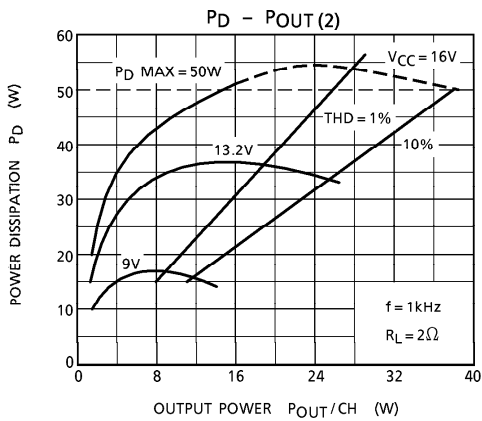
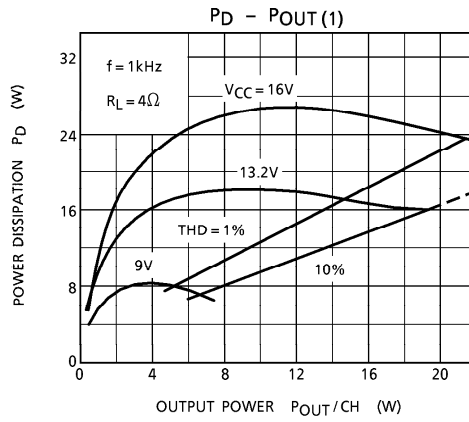
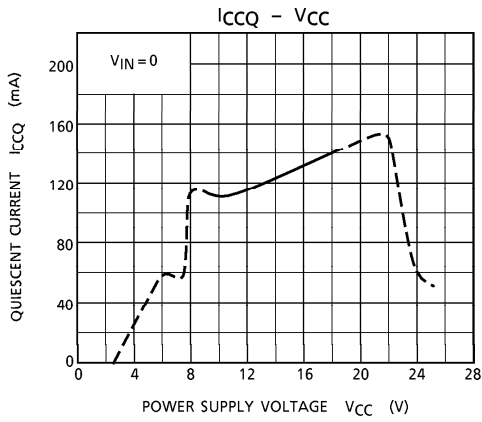

**OUTLINE DRAWING**  
HZIP17-P-2.00

Unit : mm

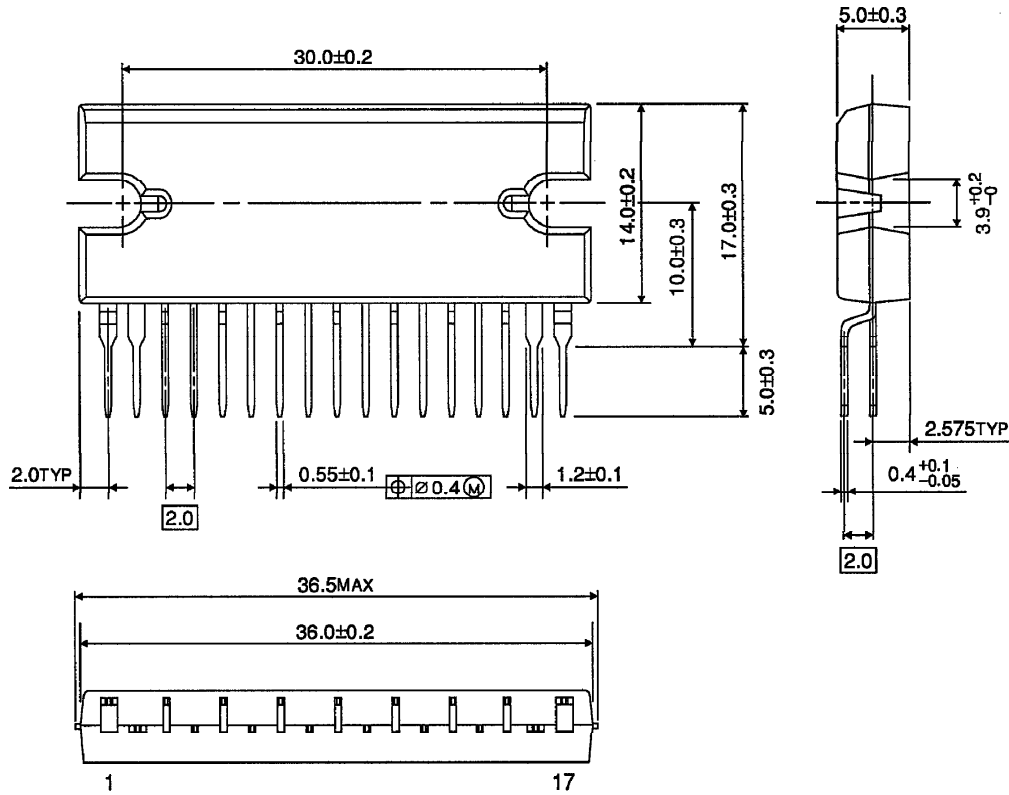

Weight : 9.8g (Typ.)

TA8233AH - 13\*

1996-09-02

**TOSHIBA CORPORATION**