

TOSHIBA BIPOLAR LINEAR INTEGRATED CIRCUIT SILICON MONOLITHIC

TA7250BP, TA7251BP

30W BTL AUDIO POWER AMPLIFIER

The TA7250BP, TA7251BP are BTL audio power amplifier for consumer applications.

This IC provides high output power of 23W and also provides wide output power band width.

Normal (TA7250BP) and Reverse (TA7251BP) for easier layout design of PC-board when used in BTL-Stereo application.

FEATURES

- High Output Power
 - : $P_{OUT(1)} = 23W$ (Typ.)
($V_{CC} = 13.2V$, $f = 1kHz$, $THD = 10\%$, $R_L = 4\Omega$)
 - $P_{OUT(2)} = 30W$ (Typ.)
($V_{CC} = 13.2V$, $f = 1kHz$, $THD = 10\%$, $R_L = 2\Omega$)
- Excellent Output Power Band Width
 - : $P_{OUT(3)} = 18W$ (Typ.)
($V_{CC} = 13.2V$, $f = 50Hz \sim 20kHz$, $THD = 1\%$, $R_L = 4\Omega$)
- Low Distortion
 - : $THD = 0.015\%$ (Typ.) ($V_{CC} = 13.2V$, $f = 1kHz$, $P_{OUT} = 4W$, $R_L = 4\Omega$)
- Built In Protector Circuit
 - : Thermal Shout Down, Over Voltage Protection (Typ. $V_{CC} = 21V$)
ASO Protection (R_L Short, Out to GND, Out to V_{CC})
- Operating Supply Voltage Range : $V_{CC(opr.)} = 9 \sim 18V$

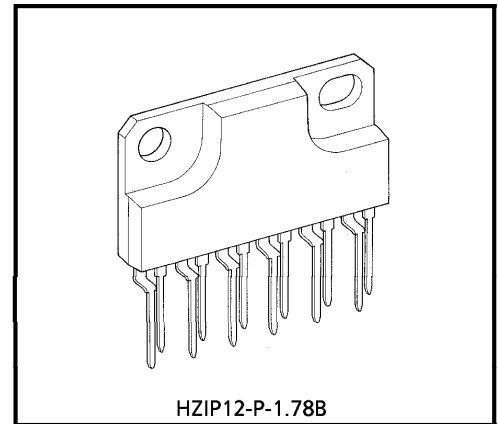

Weight : 4.04g (Typ.)

BLOCK DIAGRAM

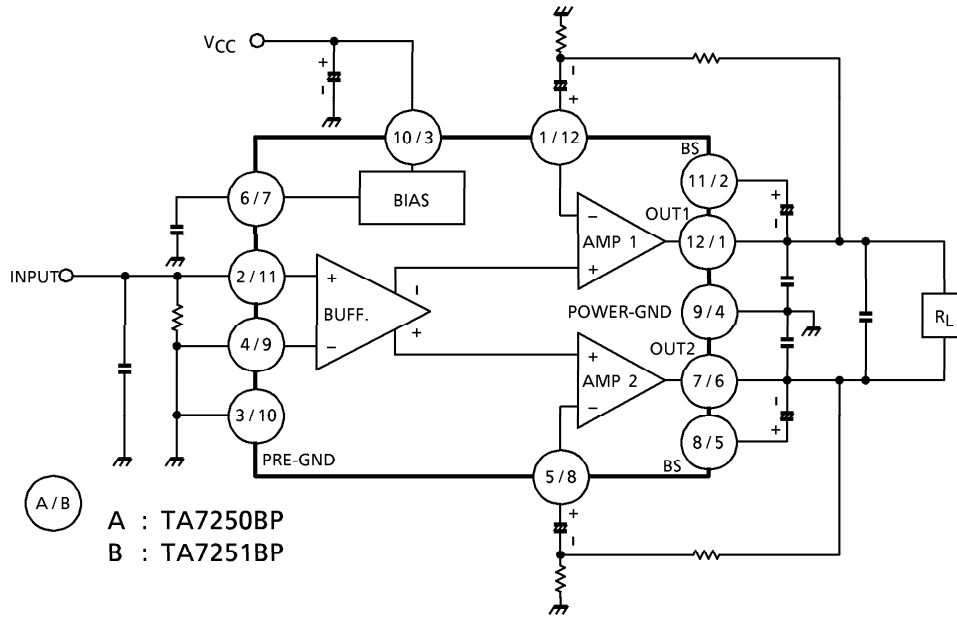

APPLICATION INFORMATION

(This explanatory terminal number is for TA7250BP)

1. Voltage gain

The closed loop voltage gain : G_V is determined by R_{f1} , R_{f2} and R_0 .

If $R_0 \gg R_{f1} > R_{f2}$

$$G_V \approx 20 \log \frac{R_{f1}}{R_{f2}} + 6 \text{ (dB)}$$

(R_0 is established $20k\Omega$)

Care must be taken, since the current "I" flows to R_{f1} and R_{f2} from quiescent output voltage at pin ⑫ / ⑦ and it is impossible decrease so much R_{f1} and R_{f2} .

When $G_V = 40\text{dB}$, it is recommended to use R_{f1} for $1k\Omega$ and R_{f2} for 20Ω .

2. Oscillation prevention

For the oscillation prevention, the capacitors should be inserted output terminal to GND and output to another output.

These are recommended to use the polyester film capacitor which temperature characteristics are better.

If use ceramic capacitor, the characteristics is liable to be influenced by temperature, than it is better to use the capacitor of which capacity is larger than the recommended value, surely carry out the temperature test, and confirm the oscillation allowance.

Especially when using this IC with the voltage gain reduced or with the feedback amount increased, the phase inversion is produced in high frequency and the oscillation is liable to be generated.

Therefore, use this IC at $G_V = 40\text{dB}$ or over after sufficiently checking the capacity of capacitor, type of capacitor and mounting position of capacitor.

3. Aso circuit

This IC incorporates the protection circuit of out to V_{CC} , Out to GND and shorting between output and another output.

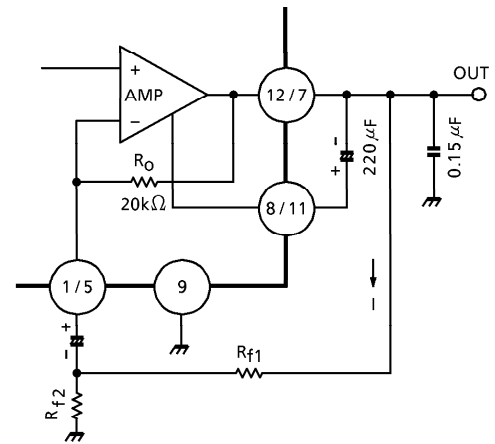

(Fig.1)

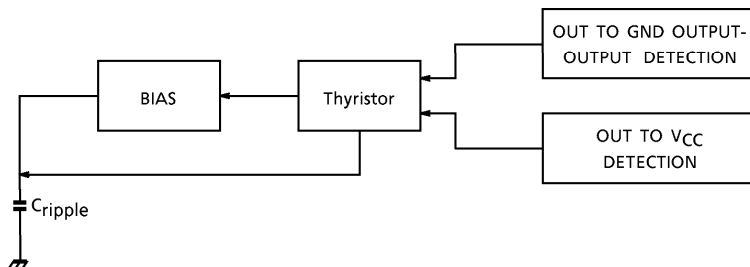

(Fig.4)

4. R.R. characteristic of ripple rejection

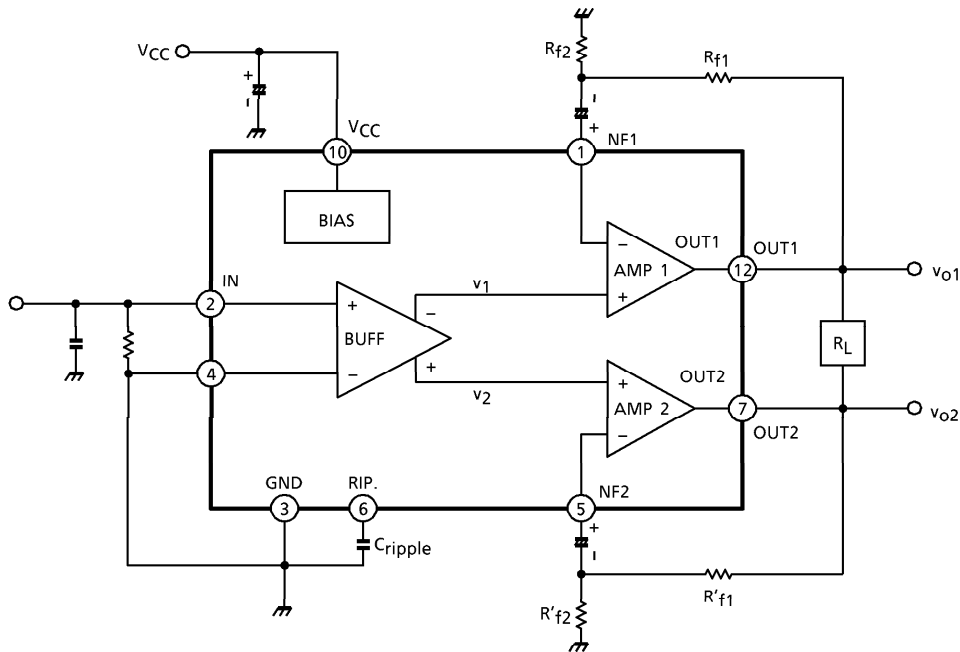

Since the capacity of ripple capacitor of this IC is small R.R., characteristic is influenced described below.

- (1) Because C_{ripple} is small (recommended value $0.033\mu\text{F}$), the ripple components produced in the bias system are output at the primary stage phase inversion amplifier which gain 1. These turn into the input signals v_1 , v_2 of the power amplifier stage.
- (2) v_1 and v_2 are amplifier through the power stage and turned into $v_{o1} - v_{o2}$. However, because of the BTL operation, $|v_{o1} - v_{o2}|$ appear as the output ripple voltage. Therefore, by the gain dispersion of the power stage of ch-1 and ch-2, that is by the resistance ratio dispersion of the external feedback resistances R_{f1} , R_{f2} , R'_{f1} , R'_{f2} and inside IC, R.R. characteristic is determined.
Since the pair characteristic of the external feedback resistances ch-1 and ch-2 influences R.R. characteristic, it is advisable to use the high precision resistance of high characteristic.

5. Capacity of ripple filter

The ON/OFF time constant of the protector of this IC is determined by the capacity of pin⑥ ripple filter terminal.

Therefore, with the capacity expansion of the ripple capacitor, the ripple rejection is improved, however, the following two problems arise.

- (1) Interruption of sound at excessive input.
- (2) Reduction of the protector strength at V_{CC} -short, GND short or OUT-OUT short. Consequently, the capacity of the ripple capacitor is recommended to by $0.033\mu\text{F}$.

STANDARD PRINT PATTERN

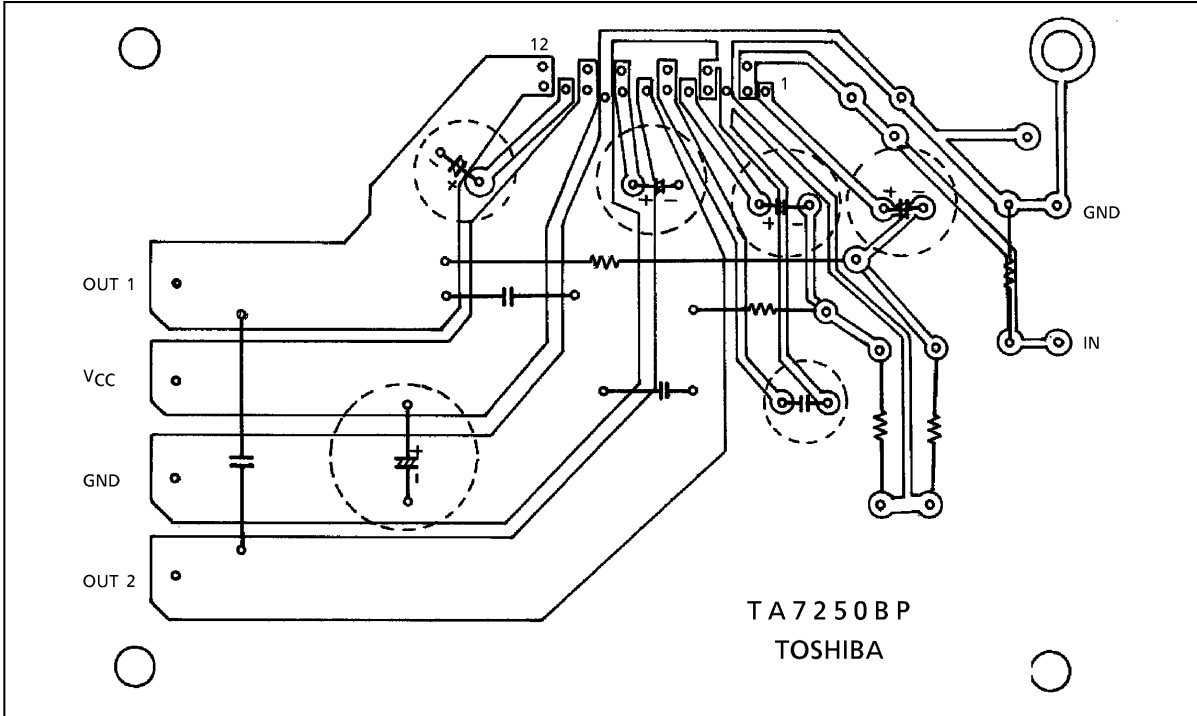

(Under view)

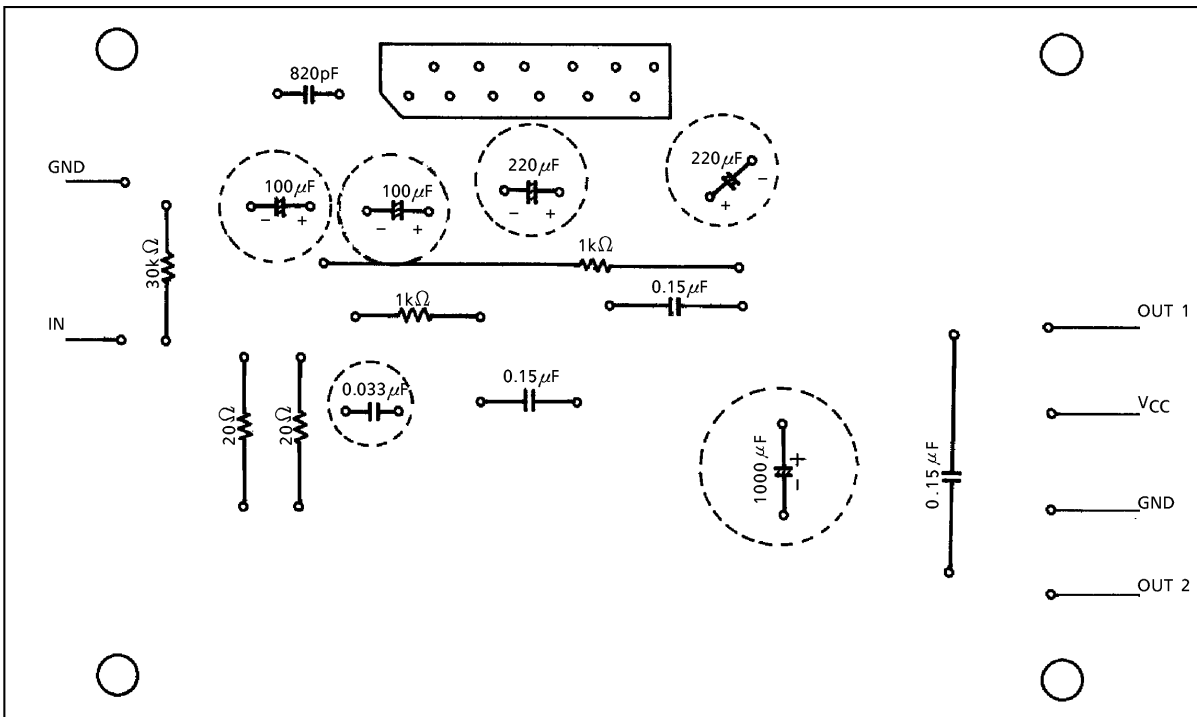

(Parts description)

MAXIMUM RATINGS (Ta = 25°C)

CHARACTERISTIC	SYMBOL	RATING	UNIT
Peak Supply Voltage (0.2s)	V _{CC} (surge)	50	V
DC Supply Voltage	V _{CC} (DC)	25	V
Operating Supply Voltage	V _{CC} (opr)	18	V
Output Current (Peak)	I _o (peak)	9	A
Power Dissipation	P _D	25	W
Operating Temperature	T _{opr}	- 30~85	°C
Storage Temperature	T _{stg}	- 55~150	°C

ELECTRICAL CHARACTERISTICS

(Unless otherwise specified, V_{CC} = 13.2V, R_L = 4Ω, R_g = 600Ω, f = 1kHz, Ta = 25°C)

CHARACTERISTIC	SYMBOL	TEST CIR-CUIT	TEST CONDITION	MIN.	TYP.	MAX.	UNIT
Quiescent Current	I _{CCQ}	—	V _{IN} = 0	—	120	200	mA
Output Power	P _{OUT} (1)	—	THD = 10%	20	23	—	W
	P _{OUT} (2)	—	THD = 10%, R _L = 2Ω	—	30	—	W
	P _{OUT} (3)	—	THD = 1%, f = 50Hz~20kHz	—	18	—	W
Total Harmonic Distortion	THD	—	P _{OUT} = 4W	—	0.015	0.1	%
Voltage Gain	G _V	—	V _{IN} = 2.45mV _{rms}	39.5	41	42.5	dB
Output Noise Voltage	V _{NO} (1)	—	R _g = 0, DIN45405 Noise filter	—	0.25	—	mV _{rms}
	V _{NO} (2)	—	R _g = 10kΩ, BW = 20Hz~20kHz	—	0.35	0.9	mV _{rms}
Ripple Rejection Ratio	R.R.	—	f = 100Hz V _{ripple} = 0.775V _{rms} (0dBm)	40	47	—	dB

TYP. DC VOLTAGE OF EACH TERMINAL (V_{CC} = 13.2V, Ta = 25°C)

TERMINAL No.		1	2	3	4	5	6	7	8	9	10	11	12
DC Voltage (V)	TA7250BP	1.95	0.01	GND	0	1.95	6.6	6.6	12.5	GND	V _{CC}	12.5	6.6
	TA7251BP	6.6	12.5	V _{CC}	GND	12.5	6.6	6.6	1.95	0	GND	0.01	1.95

TEST CIRCUIT

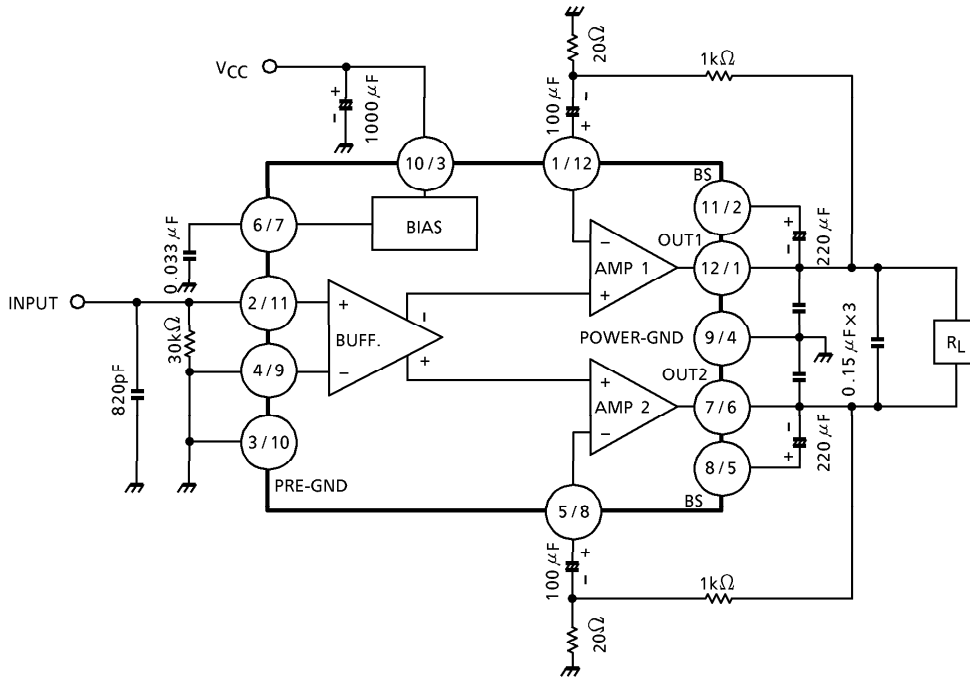

A/B
 A : TA7250BP
 B : TA7251BP

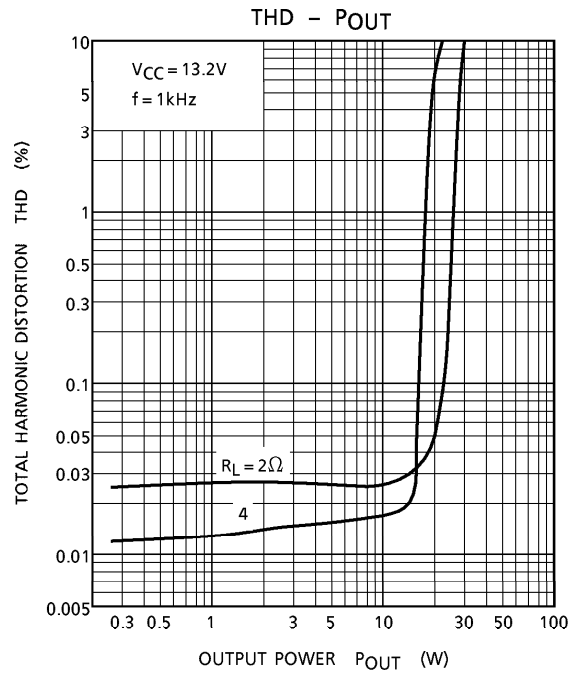
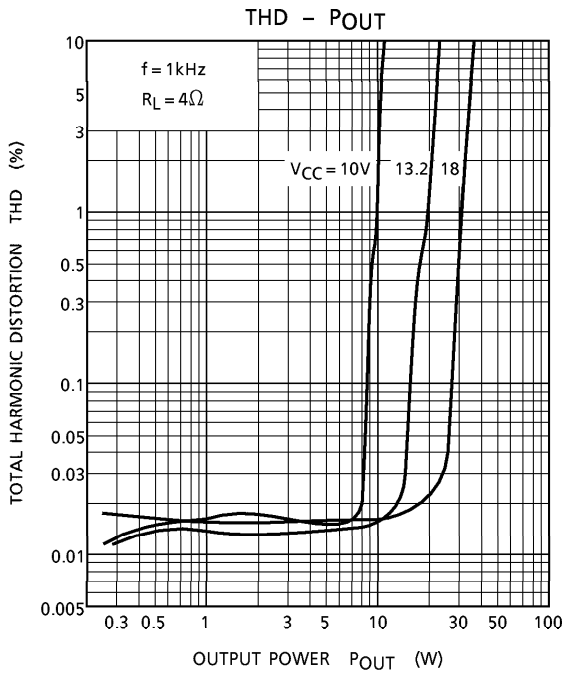
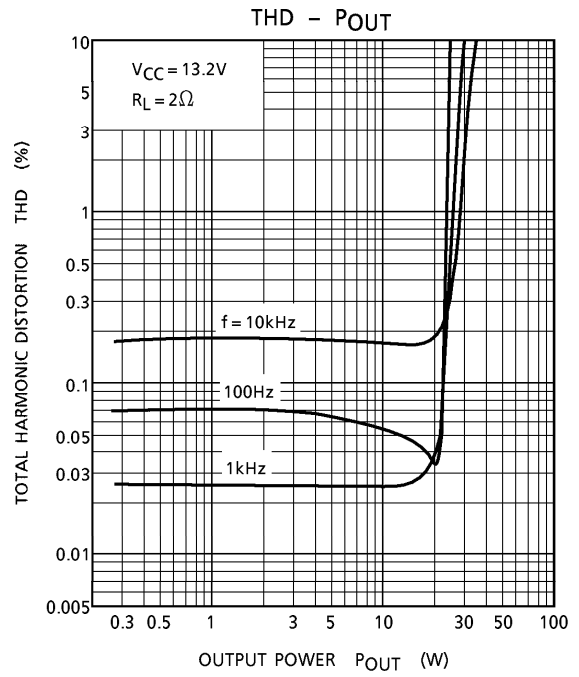
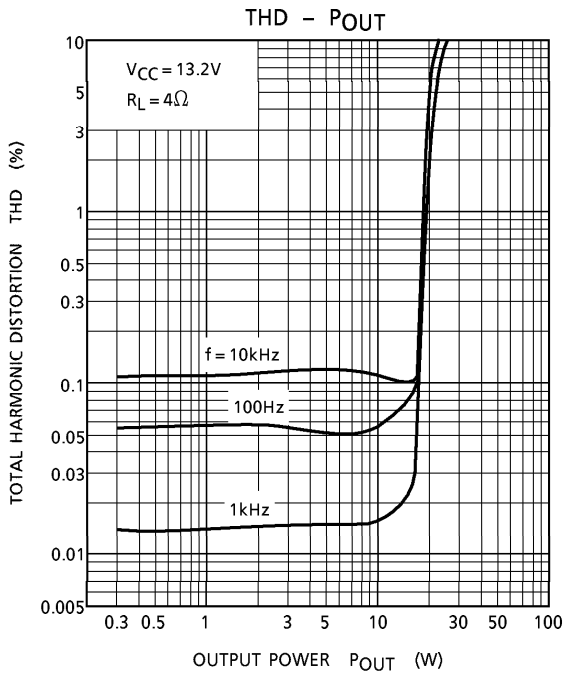

THD (NOISE) - P_{OUT}

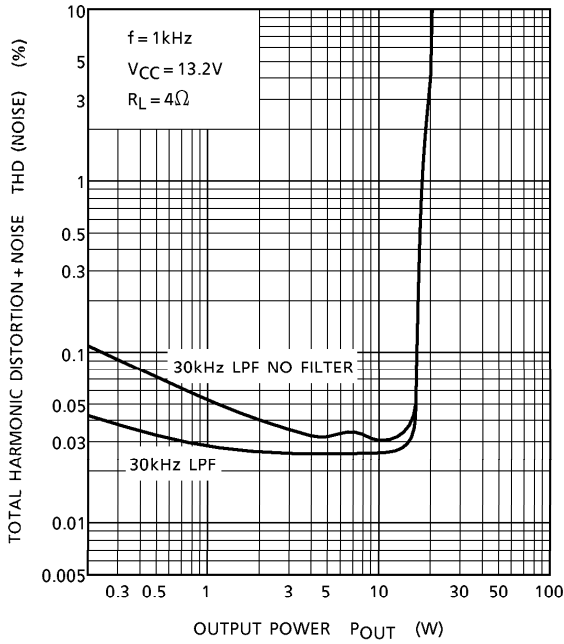

THD - f

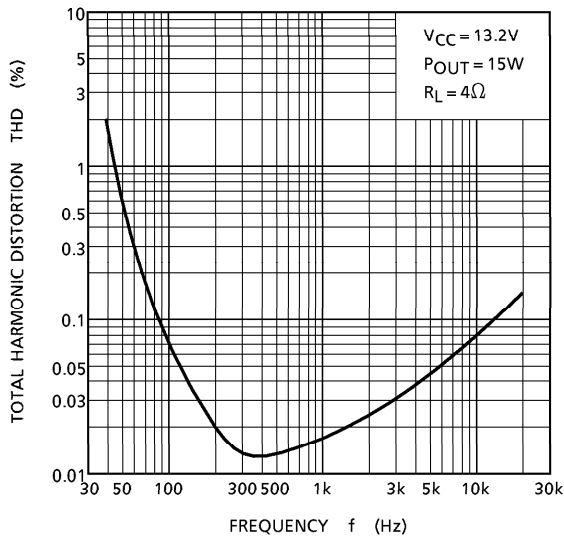

P_D - P_{OUT}

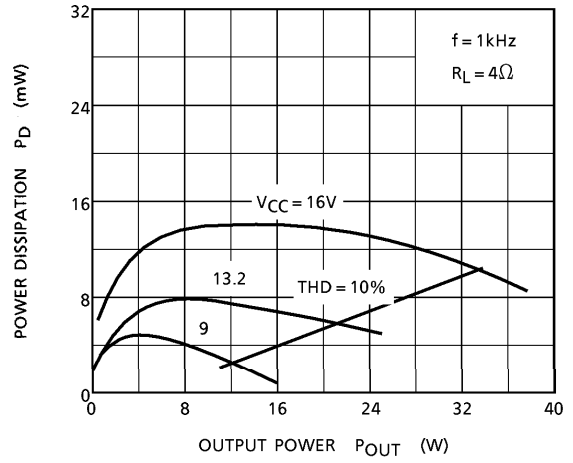

P_D - P_{OUT}

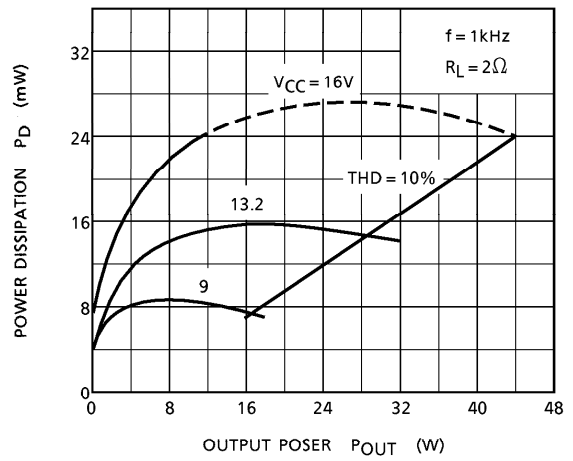

P_{OUT} - V_{CC}

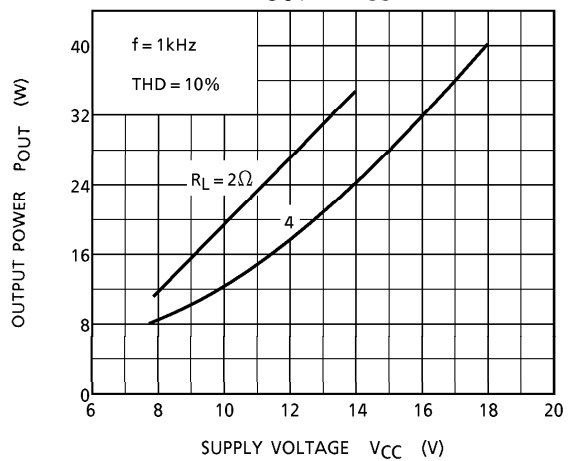

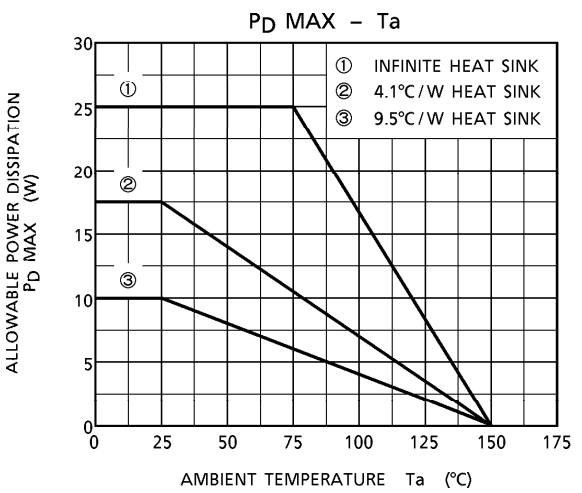
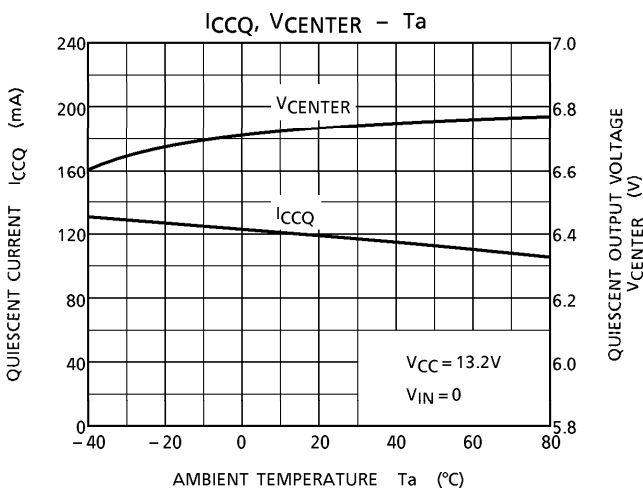
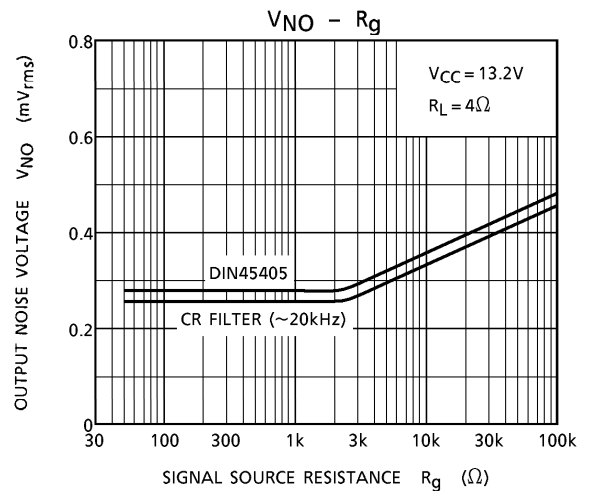
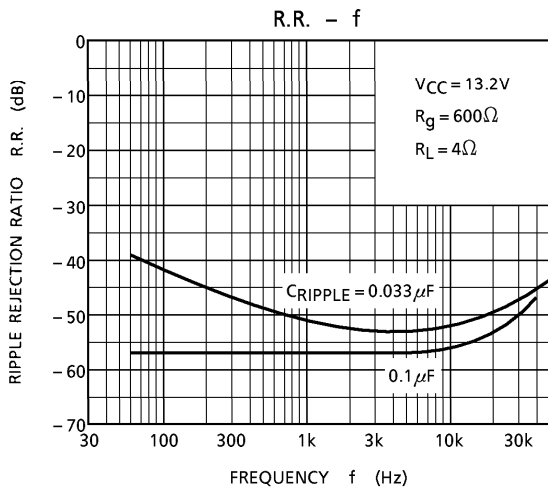
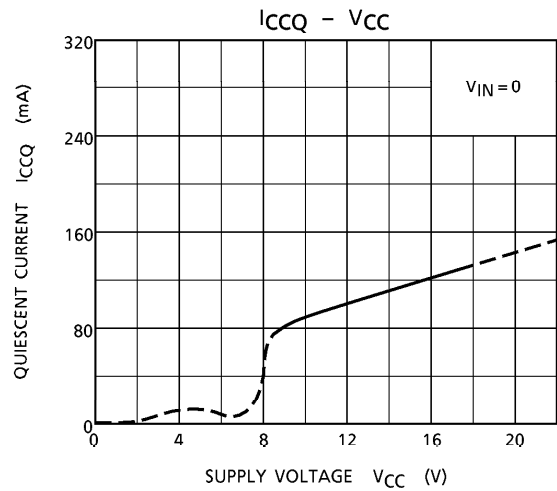
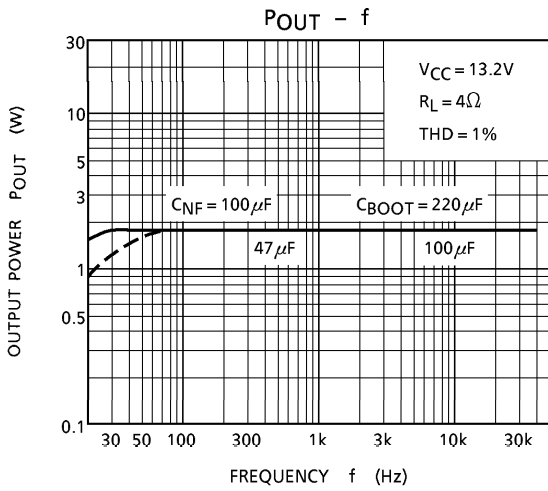

PACKAGE DIMENSIONS
HZIP12-P-1.78B

Unit : mm

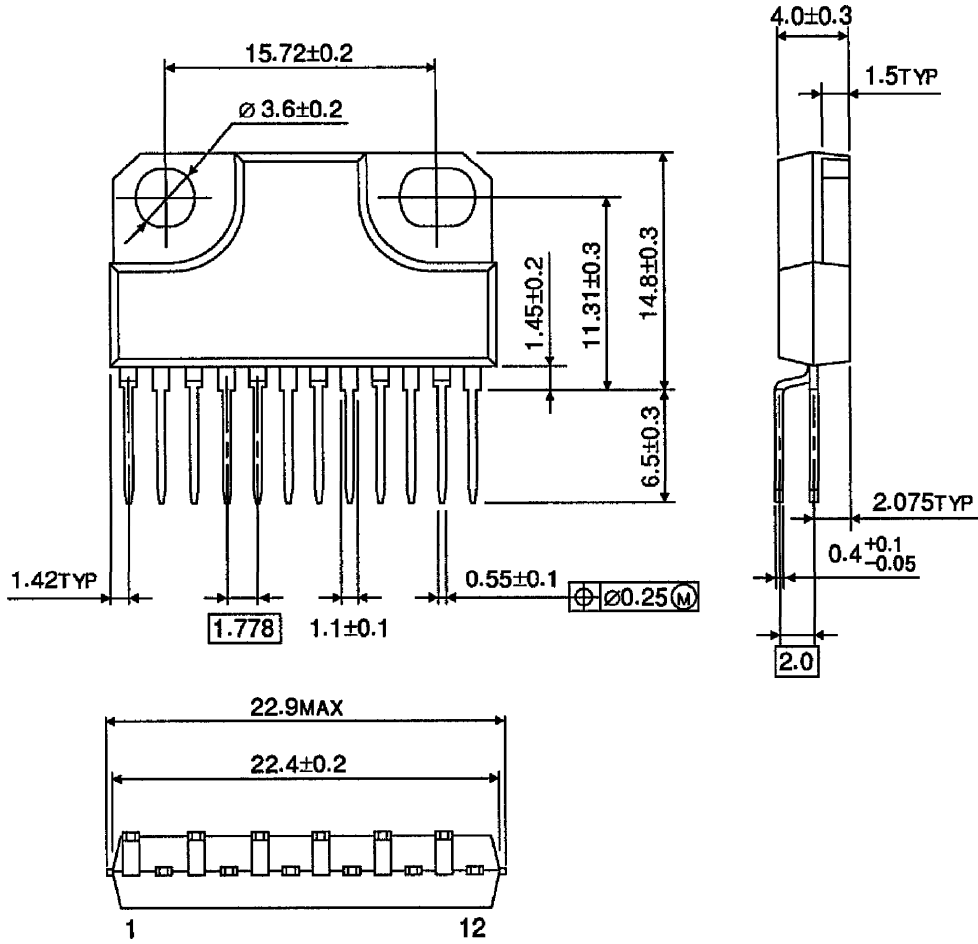

Weight : 4.04g (Typ.)

RESTRICTIONS ON PRODUCT USE

000707EBA

- TOSHIBA is continually working to improve the quality and reliability of its products. Nevertheless, semiconductor devices in general can malfunction or fail due to their inherent electrical sensitivity and vulnerability to physical stress. It is the responsibility of the buyer, when utilizing TOSHIBA products, to comply with the standards of safety in making a safe design for the entire system, and to avoid situations in which a malfunction or failure of such TOSHIBA products could cause loss of human life, bodily injury or damage to property. In developing your designs, please ensure that TOSHIBA products are used within specified operating ranges as set forth in the most recent TOSHIBA products specifications. Also, please keep in mind the precautions and conditions set forth in the "Handling Guide for Semiconductor Devices," or "TOSHIBA Semiconductor Reliability Handbook" etc..
- The TOSHIBA products listed in this document are intended for usage in general electronics applications (computer, personal equipment, office equipment, measuring equipment, industrial robotics, domestic appliances, etc.). These TOSHIBA products are neither intended nor warranted for usage in equipment that requires extraordinarily high quality and/or reliability or a malfunction or failure of which may cause loss of human life or bodily injury ("Unintended Usage"). Unintended Usage include atomic energy control instruments, airplane or spaceship instruments, transportation instruments, traffic signal instruments, combustion control instruments, medical instruments, all types of safety devices, etc.. Unintended Usage of TOSHIBA products listed in this document shall be made at the customer's own risk.
- The products described in this document are subject to the foreign exchange and foreign trade laws.
- The information contained herein is presented only as a guide for the applications of our products. No responsibility is assumed by TOSHIBA CORPORATION for any infringements of intellectual property or other rights of the third parties which may result from its use. No license is granted by implication or otherwise under any intellectual property or other rights of TOSHIBA CORPORATION or others.
- The information contained herein is subject to change without notice.