

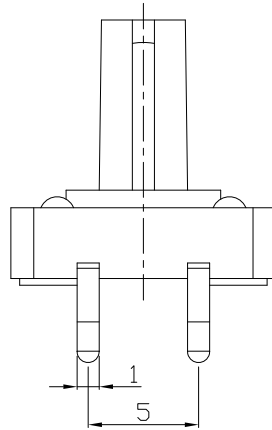

RoHS
Compliant
2002/95/EC

REV.	ECN.	NO.	APPD.

DIMENSIONS

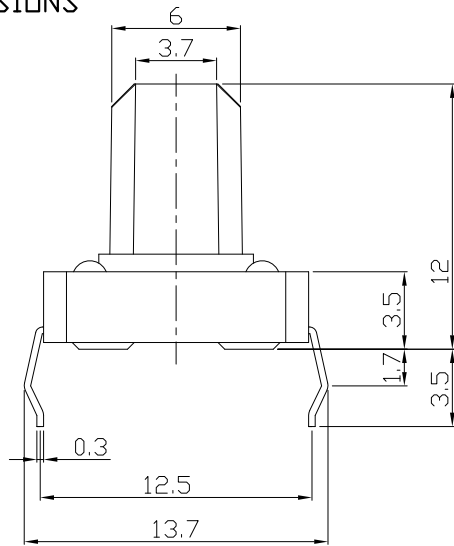

CIRCUIT DIAGRAM

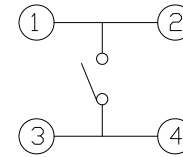

PRODUCT IMAGE

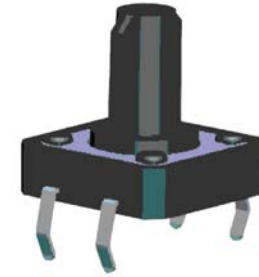

P.C.B MOUNTING PATTERN DIMENSION

The following soldering patterns are recommended for reflow soldering

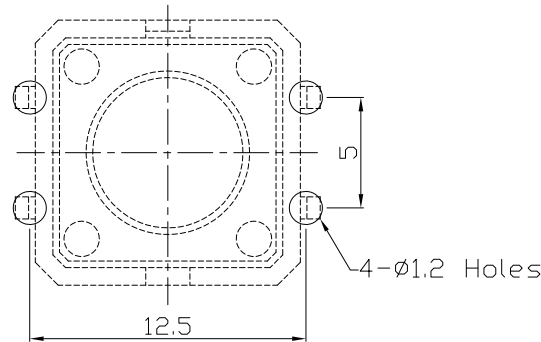
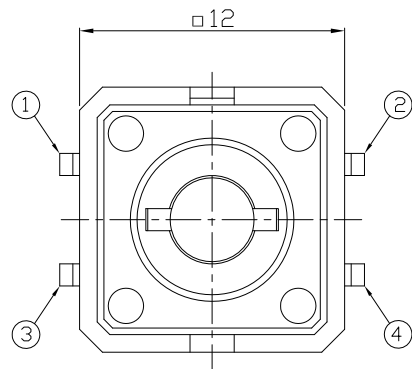

ELECTRO-MECHANICAL CHARACTERISTICS

Refer to additional specifications

Rating	DC 12V 50mA	
Contact Resistance	100mΩ Max.	
Travel	0.3 ± 0.1mm	
Operating Force	130,160±30gf	250±50gf
Operating Life(cycles)	100,000	

.X ±0.3	X. ±2*	UNITS mm
		MAT'L
		SEE NOTE
		FINISH
		SEE NOTE
		Q'TY

THESE DRAWINGS AND SPECIFICATIONS ARE THE PROPERTY OF ACCURATE INNOTECH INC AND SHALL NOT BE REPRODUCED, COPIED OR USED IN ANY MANNER WITHOUT THE PRIOR WRITTEN CONSENT OF ACCURATE INNOTECH INC.

雅安科技有限公司 ACCURATE INNOTECH INC.			
TITLE: TACT SWITCH		PART NO.: AT-1103A SERIES	
DR: <i>Ricky</i> 2014/03/27		DWG NO.: ASI-1103A	
CHKD: <i>Ricky</i> 2014/03/27		SCALE	SHEET
APPD:		1:1	1/1
		REV.	CUSTOMER DRAWING
		A	