

Carbon Film Resistors Discontinued

Type: **ERDS1 (0.5 W)**
ERDS2 (0.25 W)
ERD25 (0.25 W)

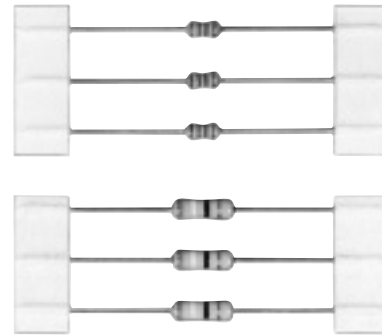

■ Features

- Reliability High reliability by using carbon film
- Automatic insertion Taping style for automatic inserting machines
- Marking 4 color code marking
- Flame Retardant Using UL 94 V-0 approved coating for flame retardant type
- Reference Standard ... IEC 60115-2, JIS C 5201-2

■ Explanation of Part Numbers

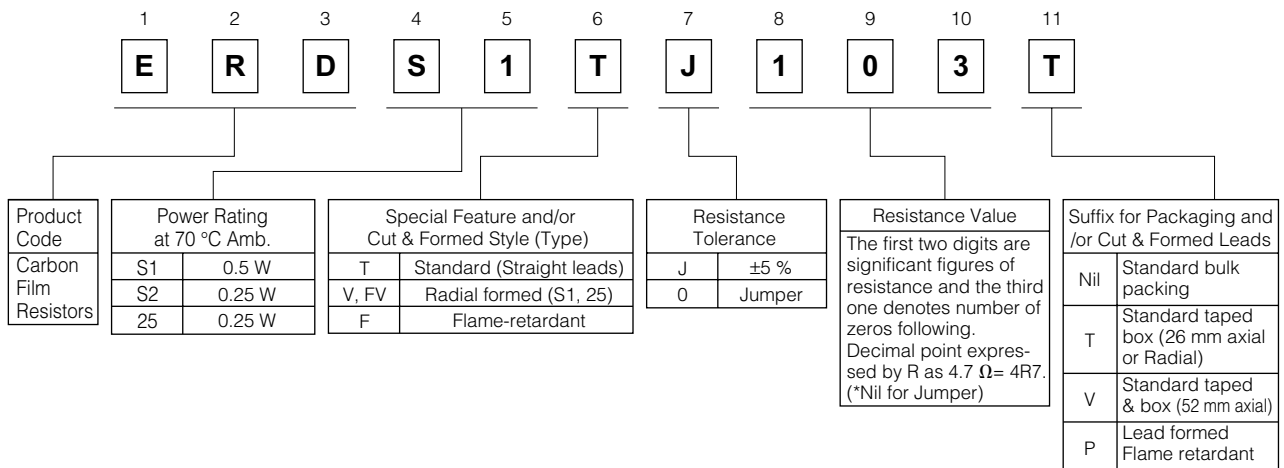

■ Construction

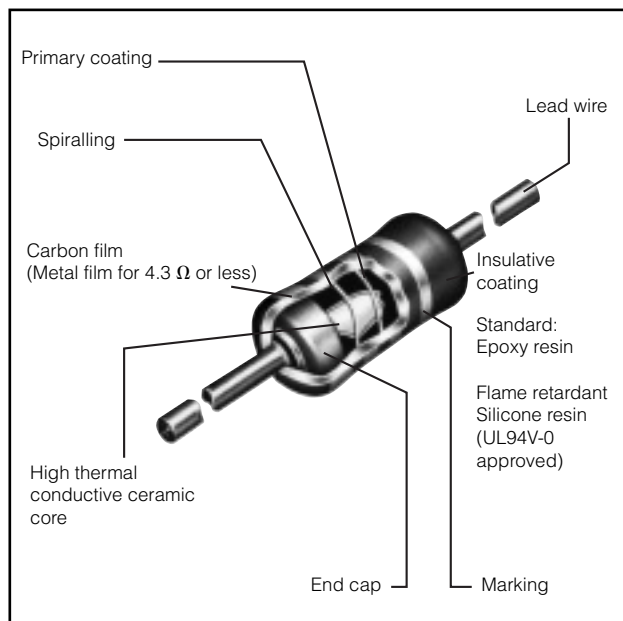

■ Dimensions in mm (not to scale)

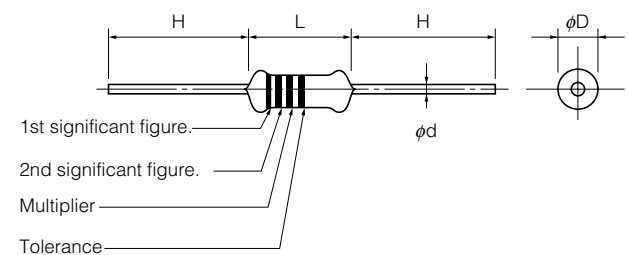

See Page ER131 for color code indication
 Standard Quantity : 2000 pcs.

Type	Dimensions (mm)				Mass (Weight) [mg/pc.]
	L	φD	φd	H	
ERDS1T ERDS1F	6.35 ^{+0.65} _{-0.35}	2.30 ^{+0.50} _{-0.30}	0.60 ^{±0.05}	20 min.	228
ERDS2T ERDS2F	3.20 ^{±0.20}	1.70 ^{+0.20} _{-0.10}	0.45 ^{±0.05}	20 min.	107
ERD25T ERD25F	6.35 ^{+0.65} _{-0.35}	2.30 ^{+0.50} _{-0.30}	0.60 ^{±0.05}	20 min.	228

■ Ratings

Type	Power Rating at 70 °C (W)	Limiting Element Voltage (Maximum RCWV) ⁽¹⁾ (V)	Maximum Overload Voltage ⁽²⁾ (V)	Maximum Intermittent Overload Voltage ⁽³⁾ (V)	Dielectric Withstanding Voltage (VAC)	Standard Resistance Value	Resistance Tolerance (%)	Resistance Range (Ω)	
								min.	max.
ERDS1T	0.5	300	600	750	500	E24	±5(J)	1	3.3 M
ERDS1F (Flame Retardant)					350				1 M
ERDS2T	0.25	250	500	750	300	E24	±5(J)	1	2.2 M
ERDS2F (Flame Retardant)					200				1 M
ERDS2T0	Jumper Rated Current : 2 A, Resistance : < 50 mΩ								
ERD25T	0.25	300	600	750	500	E24	±5(J)	1	3.3 M
ERD25F (Flame Retardant)					350				1 M
ERD25T0	Jumper Rated Current : 2 A, Resistance : < 50 mΩ								

(1) Rated Voltage= $\sqrt{\text{Power Rating} \times \text{Resistance Value}}$ or Limiting Element Voltage (max. RCWV), whichever is less.
 (RCWV: Rated Continuous working Voltage).
 (2) Overload (Short-time Overload) Test Voltage (SOTV) shall be determined from $\text{SOTV}=2.5 \times \text{Power Rating}$ or max. Overload Voltage listed above whichever less.
 (3) Intermittent Overload Test Voltage (IOTV) shall be determined from $\text{IOTV}=4 \times \text{Power Rating}$ ($\text{IOTV}=3 \times \text{Power Rating}$ for ERDS2 type) or max. Intermittent Overload Voltage listed above whichever less.

Power Derating Curve

For resistors operated in ambient temperatures above 70 °C, power rating shall be derated in accordance with the figure on the right.

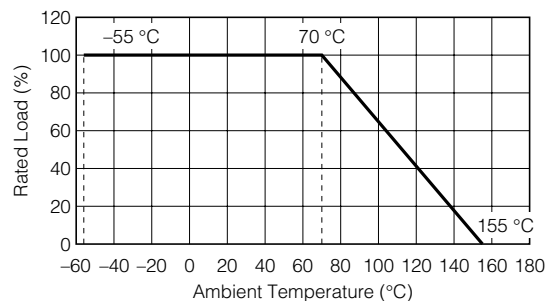

■ Performance Specifications

Characteristics	Specifications		Test Methods	
T.C.R.	Resistance Value range		Resistance value at room temperature and room temperature +100 °C	
	ERDS2	ERDS1, 25		Temperature coefficient $\times 10^{-6}/^{\circ}\text{C}$ (ppm/ $^{\circ}\text{C}$)
	4.3 Ω or less	4.3 Ω or less		±350
	4.7 Ω to 62 kΩ	4.7 Ω to 51 kΩ		-150 to -350
	68 kΩ to 200 kΩ	56 kΩ to 430 kΩ		-150 to -500
	220 kΩ to 510 kΩ	470 kΩ to 910 kΩ	-150 to -700	
	560 kΩ or over	1 MΩ or over	-150 to -1000	

■ Shape and Packaging

● Bulk type (Lead forming)

Standard forming

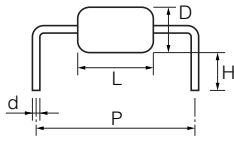

Type	Part Numbers	Std. Qty. (PCS)	L	ϕD	P	H	d
Carbon Film R	ERDS2TJ□□□A	2000	3.2±0.2	1.7 ^{+0.2} _{-0.1}	5.0±0.5	4.5 ^{+1.5} _{-0.5}	0.45
	ERD25TJ□□□B		6.35 ^{+0.65} _{-0.35}	2.3 ^{+0.5} _{-0.3}	10.0±0.5	4.5 ^{+1.5} _{-0.5}	0.6
	ERDS1TJ□□□B						

Radial forming

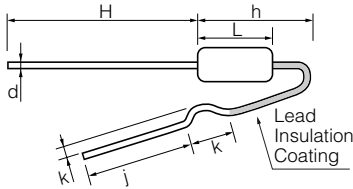

Type	Part Numbers	Std. Qty. (PCS)	L	ϕD	H	h	k	j	d
Carbon Film R	ERD25VJ□□□□	2000	6.35 ^{+0.65} _{-0.35}	2.3 ^{+0.5} _{-0.3}	20 min.	9.5 min.	2.0 ^{+0.5}	6.0 ^{+2.0} _{-1.0}	0.6
	ERD25FVJ□□□□								
	ERDS1VJ□□□□								
	ERDS1FVJ□□□□								

Self standing form

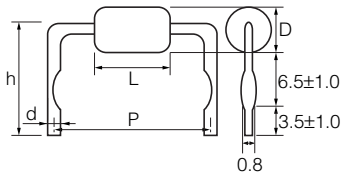

Type	Part Numbers	Std. Qty. (PCS)	L	ϕD	P	h	d
Carbon Film R	ERD25FJ□□□□P	2000	6.35 ^{+0.65} _{-0.35}	2.3 ^{+0.5} _{-0.3}	10.0±1.5	11.5±1.0	0.65
	ERDS1FJ□□□□P						

● Axial taping type

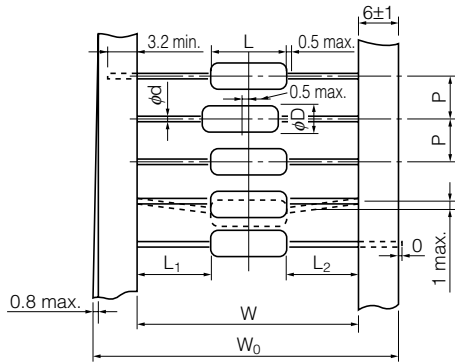

Shape	L max.	ϕD max.	ϕd	P ±0.3	W	W ₀
①	3.4	1.9	0.45	5.0	26 ⁺¹ ₋₀	41.5 max.
②	3.4	1.9	0.45	5.0	52±1	64.5±0.5
③	6.5	2.5	0.6	5.0	26 ⁺¹ ₋₀	41.5 max.
④	6.5	2.5	0.6	5.0	52±1	64.5±0.5

- ① |L₁-L₂| ≤ 1.0
- ② Cumulative 250±2mm by 50 pitch

Flat box

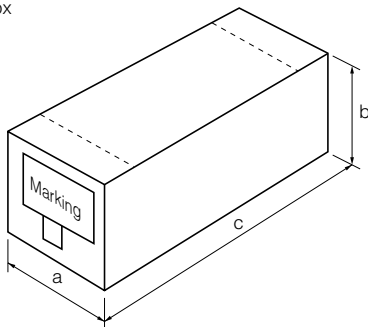

Packaging	Shape	Type	Part Numbers	Std. Qty. (pcs./box)	Size of box a×b×c (mm)
26 mm Axial taping	①	Carbon Film R	ERDS2TJ□□□□T	5000	52×85×255
			ERDS2FJ□□□□T		
52 mm Axial taping	②	Carbon Film R	ERDS2TJ□□□□V	5000	78×85×255
			ERDS2FJ□□□□V		
26 mm Axial taping	③	Carbon Film R	ERD25TJ□□□□T	4000	52×95×255
			ERD25FJ□□□□T		
			ERDS1TJ□□□□T		
52 mm Axial taping	④	Carbon Film R	ERD25TJ□□□□V	2000	78×58×255
			ERD25FJ□□□□V		
			ERDS1TJ□□□□V		

● Radial Taping type

Radial Taping

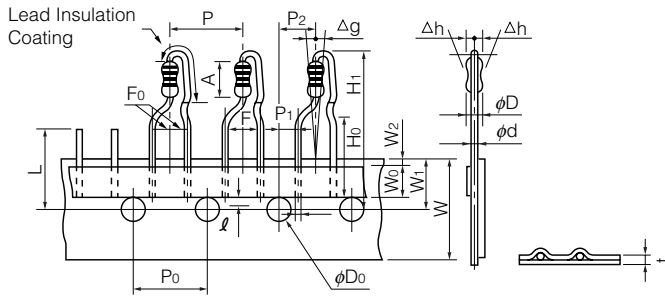

Type	Part Numbers	Std. Qty. (pcs.)
Carbon Film R	ERDS1VJ□□□□T	2000
	ERD25VJ□□□□T	
	ERDS1FVJ□□□□T	
	ERD25FVJ□□□□T	

Dimensions (mm)		Dimensions (mm)		Dimensions (mm)	
P	12.7±1.0	W ₀	5 min.	l	0 max.
P ₀	12.7±0.3	W ₁	9.0±0.5	t	0.7±0.2
P ₁	3.85±0.70	W ₂	3 max.	Δg	0±2.5 °
P ₂	6.35±1.00	H ₁	32 max.	Δh	0±2
F	5.0±0.5	H ₀	16.0±0.5	A	6.35 ^{+0.65} _{-0.35}
F ₀	2.5±0.5	φD ₀	4.0±0.2	φD	2.3 ^{+0.5} _{-0.3}
W	18.0±0.5	L	11 max.	φd	0.60±0.05

Radial Taping for small type

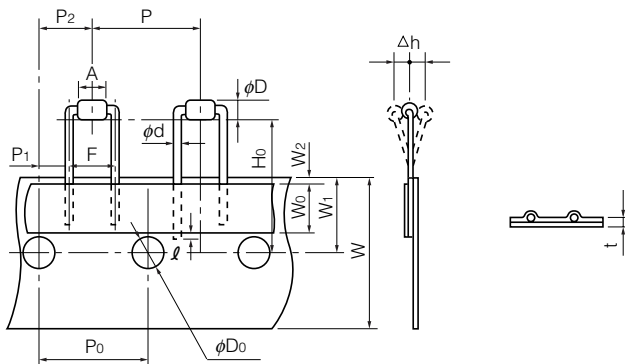

Type	Part Numbers	Std. Qty. (pcs.)
Carbon Film R	ERDS2TYJ□□□□T	2000

Dimensions (mm)		Dimensions (mm)		Dimensions (mm)	
P	12.7±1.0	W ₀	5 min.	Δh	0±2
P ₀	12.7±0.3	W ₁	9.0±0.5	t	0.7±0.2
P ₁	3.85±0.70	W ₂	3 max.	A	3.2±0.2
P ₂	6.35±1.00	H ₀	19.0 ^{+1.0} _{-0.5}	φD	1.7 ^{+0.2} _{-0.1}
F	5.0±0.5	φD ₀	4.0±0.2	φd	0.45±0.05
W	18.0±0.5	l	0 max.		

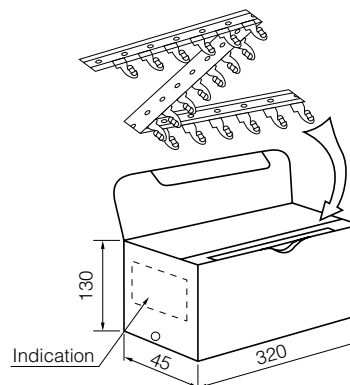

⚠ Safety Precautions

The following are precautions for individual products. Please also refer to the precautions common to Fixed Resistors shown on page ER3 of this catalog.

1. Keep the rated power and ambient temperature within the specified derating curve.
 - * When positioning and mounting Carbon Film Resistors (hereafter called the resistors), make allowance for the effect of heat generated through close contact between the resistors and neighboring components and for the temperature rise of adjacent heat-generating components.
2. If a transient load (heavy load in a short time) like a pulse is expected to be applied, check and evaluate the operations of the resistors when installed in your products before use.
When applying pulses to the resistors, keep the pulse peak within the rated voltage.
3. When the resistors' protective coatings are chipped, flawed, or removed, the characteristics of the resistors may be impaired. Take special care not to apply mechanical shock during automatic mounting or cause damage during handling of the boards with the resistors mounted.
4. Ultrasonic cleaning may cut the lead wire due to resonance. Try and check it before use.
5. Flame-retardant type
 - 1) Take special care in handling the flame-retardant type because it is covered with a special coating and is therefore by more susceptible to external shock and solvent damage than other regular types of the resistors.
 - 2) The external coating used for the flame-retardant type is not resistant to solvent. Take great care in using solvent. If problems are anticipated, then take appropriate preventive measures, such as mounting the resistors after solvent is used.

⚠ Safety Precautions (Common precautions for Fixed Resistors)

- When using our products, no matter what sort of equipment they might be used for, be sure to make a written agreement on the specifications with us in advance. The design and specifications in this catalog are subject to change without prior notice.
- Do not use the products beyond the specifications described in this catalog.
- This catalog explains the quality and performance of the products as individual components. Before use, check and evaluate their operations when installed in your products.
- Install the following systems for a failsafe design to ensure safety if these products are to be used in equipment where a defect in these products may cause the loss of human life or other significant damage, such as damage to vehicles (automobile, train, vessel), traffic lights, medical equipment, aerospace equipment, electric heating appliances, combustion/gas equipment, rotating equipment, and disaster/crime prevention equipment.
- * Systems equipped with a protection circuit and a protection device
- * Systems equipped with a redundant circuit or other system to prevent an unsafe status in the event of a single fault

(1) Precautions for use

- These products are designed and manufactured for general and standard use in general electronic equipment (e.g. AV equipment, home electric appliances, office equipment, information and communication equipment)
- These products are not intended for use in the following special conditions. Before using the products, carefully check the effects on their quality and performance, and determine whether or not they can be used.
 1. In liquid, such as water, oil, chemicals, or organic solvent
 2. In direct sunlight, outdoors, or in dust
 3. In salty air or air with a high concentration of corrosive gas, such as Cl₂, H₂S, NH₃, SO₂, or NO₂
 4. Electric Static Discharge (ESD) Environment
 - These components are sensitive to static electricity and can be damaged under static shock (ESD). Please take measures to avoid any of these environments.
 - Smaller components are more sensitive to ESD environment.
 5. Electromagnetic Environment
 - Avoid any environment where strong electromagnetic waves exist.
 6. In an environment where these products cause dew condensation
 7. Sealing or coating of these products or a printed circuit board on which these products are mounted, with resin or other materials
- These products generate Joule heat when energized. Carefully position these products so that their heat will not affect the other components.
- Carefully position these products so that their temperatures will not exceed the category temperature range due to the effects of neighboring heat-generating components. Do not mount or place heat-generating components or inflammables, such as vinyl-coated wires, near these products .
- Note that non-cleaning solder, halogen-based highly active flux, or water-soluble flux may deteriorate the performance or reliability of the products.
- Carefully select a flux cleaning agent for use after soldering. An unsuitable agent may deteriorate the performance or reliability. In particular, when using water or a water-soluble cleaning agent, be careful not to leave water residues. Otherwise, the insulation performance may be deteriorated.

(2) Precautions for storage

The performance of these products, including the solderability, is guaranteed for a year from the date of arrival at your company, provided that they remain packed as they were when delivered and stored at a temperature of 5 °C to 35 °C and a relative humidity of 45 % to 85 %.

Even within the above guarantee periods, do not store these products in the following conditions. Otherwise, their electrical performance and/or solderability may be deteriorated, and the packaging materials (e.g. taping materials) may be deformed or deteriorated, resulting in mounting failures.

1. In salty air or in air with a high concentration of corrosive gas, such as Cl₂, H₂S, NH₃, SO₂, or NO₂
2. In direct sunlight

<Package markings>

Package markings include the product number, quantity, and country of origin. In principle, the country of origin should be indicated in English.

How to express the resistance tolerance with a Matsushita part number

The resistance tolerance is identified by a single letter in accordance with the following table and the code is placed just before the resistance code in the following examples.

Tolerance Code	Tolerance (%)	Examples
W	±0.05	W1001 : 1000 Ω±0.05 %
B	±0.1	B1001 : 1000 Ω±0.1 %
C	±0.25	C1001 : 1000 Ω±0.25 %
D	±0.5	D1001 : 1000 Ω±0.5 %
F	±1	F1001 : 1000 Ω±1 %
G	±2	G1001 : 1000 Ω±2 %
J	±5	J101 : 100 Ω±5 %
K	±10	K101 : 100 Ω±10 %
M	±20	M101 : 100 Ω±20 %

Color code indication for the resistance value and the tolerance

Fixed resistors whose resistance value and tolerance are indicated by color code follow the standard below.

Color code

Color	First digit	Second digit	Third digit	Multiplier	Resistance tolerance	
					%	Code
Black	0	0	0	1		
Brown	1	1	1	10	±1	F
Red	2	2	2	10 ²	±2	G
Orange	3	3	3	10 ³	±0.05	W
Yellow	4	4	4	10 ⁴		
Green	5	5	5	10 ⁵	±0.5	D
Blue	6	6	6	10 ⁶	±0.25	C
Violet	7	7	7	10 ⁷	±0.1	B
Gray	8	8	8			
White	9	9	9			
Gold				10 ⁻¹	±5	J
Silver				10 ⁻²	±10	K
None					±20	M

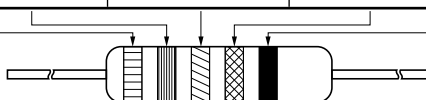

Indication example

Color code of 5 color bands

When the standard resistance value follows E48 series or 96 series, color code of the resistors are indicated by five color bands. Example below is 154 kΩ.

Example 1

1st Color	2nd Color	3rd Color	4th Color	5th Color
Brown (1)	Green (5)	Yellow (4)	Orange (1000)	Brown (±1 %)

Color code of 4 color bands

When the standard resistance value follows E6 series, 12 series or 24 series, color code of the resistors are indicated by four color bands. Example below is 15 kΩ.

Example 2

1st Color	2nd Color	3rd Color	4th Color
Brown (1)	Green (5)	Orange (1000)	Gold (±5 %)