

# CRYSTAL OSCILLATORS

## CXO (Clock Crystal Oscillator)

An CXO has a frequency-temperature characteristic obtained by crystal resonator and has no temperature compensation circuit. Therefore, SUNNY has designed it under optimum circuit conditions by circuit simulation analysis so that the best characteristics of the crystal resonators are obtained.

For the SCO series, greater miniaturization has been achieved by developing hybrid intergrated components in its circuits. It also has a hermetic construction and is completely sealed in a dual-in-line package. The crystal oscillators typified by the SCO-010 relieve the user of washing resistance problems and are widely used as the clock generator for microcomputers.

For devices using microprocessor, personal computer, office computer, facimile, computer controlled devices etc.

Model	SCO-011	SCO-012	SCO-013	
Frequency range	0.256~4 MHz	3.5~25 MHz	25~75 MHz	
Frequency stability*	± 25~± 1000 PPM			
Operating temperature range	0°C~70°C			
Storage temperature range	-55°C~+125°C			
Input voltage	+5.0V DC ± 10%		+5.0 VDC ± 5%	
Input current	70 mA Max.	40 mA Max.	70 mA Max.	
Output	Symmetry	50% ± 10% (at 1.4V)		
	Rise/Fall time	15 ns Max.	10 ns Max.	5 ns Max.
	Fanout	1 to 10 TTL gate		1 to 5 TTL gate

\*Inclusive of calibration tolerance at 25°C, operating temperature, input voltage change, load change, aging, shock and vibration.

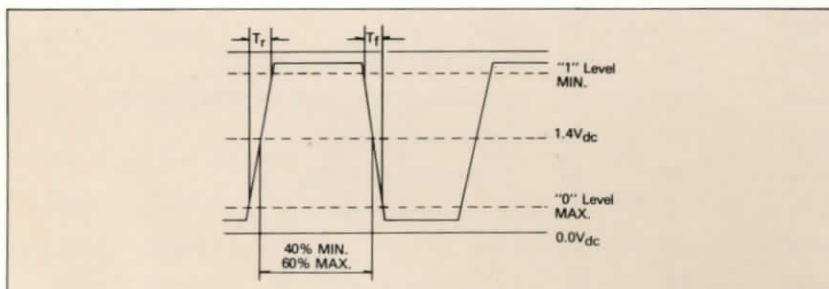
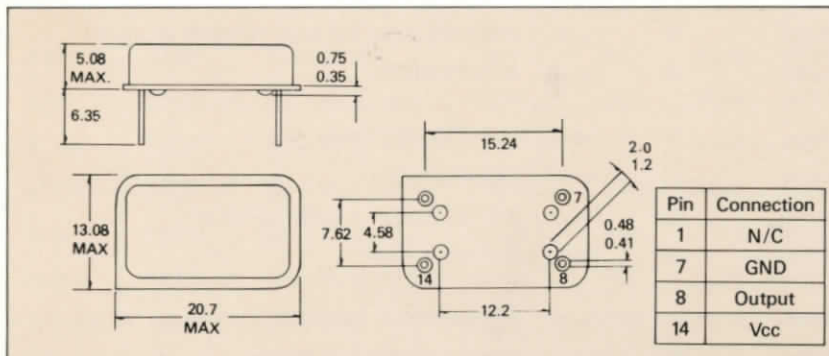

## SCO-010 Series

### GENERAL SPECIFICATIONS

### OUTLINE AND DIMENSIONS (MM)

### OUTPUT WAVE FORM

# CRYSTAL OSCILLATORS

## Features

- Compatible with 14-pin dual in line
- Drives C-MOS and TTL IC without analog design
- Quick start-up time
- Stable wave shape
- Hermetically sealed metal case

Model	SCO-021	SCO-022	SCO-023	SCO-026	
Frequency range	0.256-4 MHz	4-25 MHz	25-60 MHz	3-25 MHz	
Frequency stability*	±25~±1000 PPM				
Frequency temperature range	0°C-70°C				
Storage temperature range	-55°C-125°C				
Input voltage	5.0V DC ±10%				
Input current	8 mA Max.	15 mA Max.	30 mA Max.	25 mA Max.	
Output	Symmetry	50% ±10% (at 1.4V)		50% ±10% (at 1/2 V <sub>DD</sub> )	
	Rise/Fall time	15ns Max.	10 ns Max.	10 ns Max.	15 ns Max.
	Fanout	1 to 10 TTL gate		1 gate 1.6 mA/gate	
Remarks	TTL-AND C-MOS Compatibles			C-MOS	

\*Inclusive of calibration tolerance at 25°C, operating temperature, input voltage change, load change, aging, shock and vibration.

## SCO-020 Series

### GENERAL SPECIFICATIONS

### OUTLINE AND DIMENSIONS (MM)

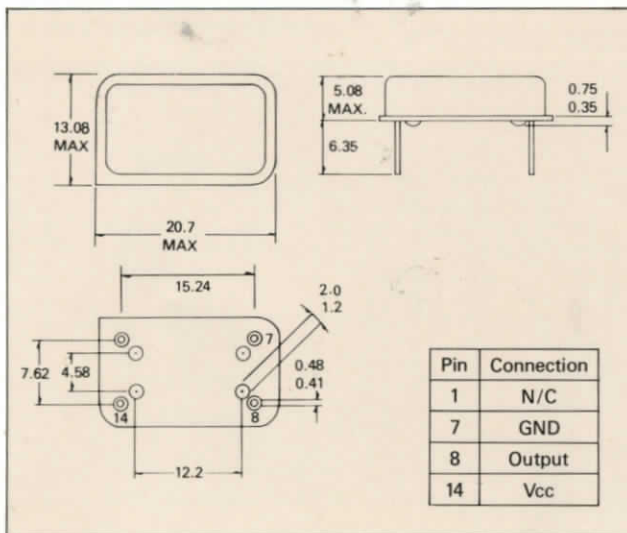

### TEST CIRCUITS

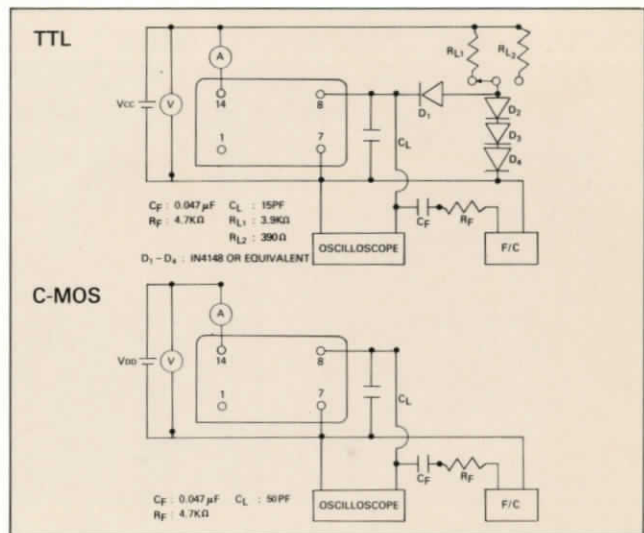

### OUTPUT WAVE FORM

#### TTL OUTPUT

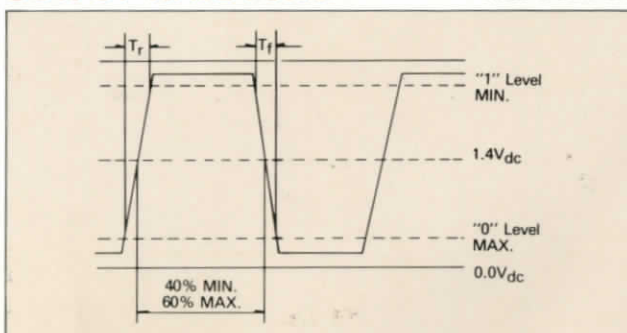

#### C-MOS OUTPUT

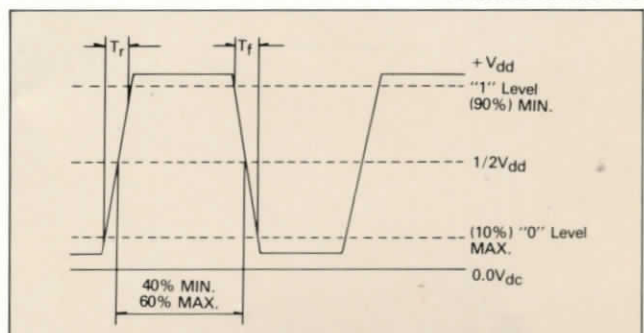

# CRYSTAL OSCILLATORS

## CXO (Clock Crystal Oscillator)

An CXO has a frequency-temperature characteristic obtained by crystal resonator and has no temperature compensation circuit. Therefore, SUNNY has designed it under optimum circuit conditions by circuit simulation analysis so that the best characteristics of the crystal resonators are obtained.

For the SCO series, greater miniaturization has been achieved by developing hybrid intergrated components in its circuits. It also has a hermetic construction and is completely sealed in a dual-in-line package. The crystal oscillators typified by the SCO-010 relieve the user of washing resistance problems and are widely used as the clock generator for microcomputers.

For devices using microprocessor, personal computer, office computer, facimile, computer controlled devices etc.

Model		SCO-011	SCO-012	SCO-013
Frequency range		0.256~4 MHz	3.5~25 MHz	25~75 MHz
Frequency stability*		±25~±1000 PPM		
Operating temperature range		0°C~70°C		
Storage temperature range		-55°C~+125°C		
Input voltage		+5.0V DC ± 10%		+5.0 VDC ± 5%
Input current		70 mA Max.	40 mA Max.	70 mA Max.
Output	Symmetry	50% ± 10% (at 1.4V)		
	Rise/Fall time	15 ns Max.	10 ns Max.	5 ns Max.
	Fanout	1 to 10 TTL gate		1 to 5 TTL gate

\*Inclusive of calibration tolerance at 25°C, operating temperature, input voltage change, load change, aging, shock and vibration.

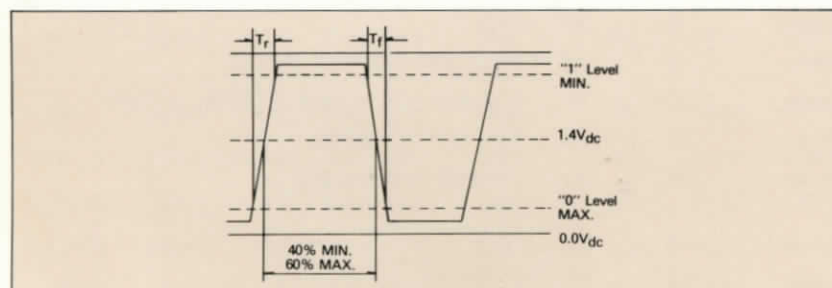
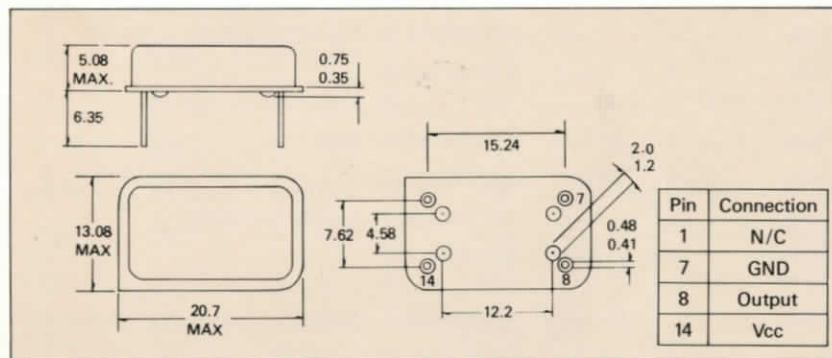

## SCO-010 Series

### GENERAL SPECIFICATIONS

### OUTLINE AND DIMENSIONS (MM)

### OUTPUT WAVE FORM

# CRYSTAL OSCILLATORS

## Features

- Compatible with 14-pin dual in line
- Drives C-MOS and TTL IC without analog design
- Quick start-up time
- Stable wave shape
- Hermetically sealed metal case

Model	SCO-021	SCO-022	SCO-023	SCO-026	
Frequency range	0.256~4 MHz	4~25 MHz	25~60 MHz	3~25 MHz	
Frequency stability*	±25~±1000 PPM				
Frequency temperature range	0°C~70°C				
Storage temperature range	-55°C~125°C				
Input voltage	5.0V DC±10%				
Input current	8 mA Max.	15 mA Max.	30 mA Max.	25 mA Max.	
Output	Symmetry	50% ± 10% (at 1.4V)		50% ± 10% (at 1/2 V <sub>DD</sub> )	
	Rise/Fall time	15ns Max.	10 ns Max.	10 ns Max.	15 ns Max.
	Fanout	1 to 10 TTL gate		1 gate 1.6 mA/gate	
Remarks	TTL-AND C-MOS Compatibles			C-MOS	

\*Inclusive of calibration tolerance at 25°C, operating temperature, input voltage change, load change, aging, shock and vibration.

## SCO-020 Series

### GENERAL SPECIFICATIONS

### OUTLINE AND DIMENSIONS (MM)

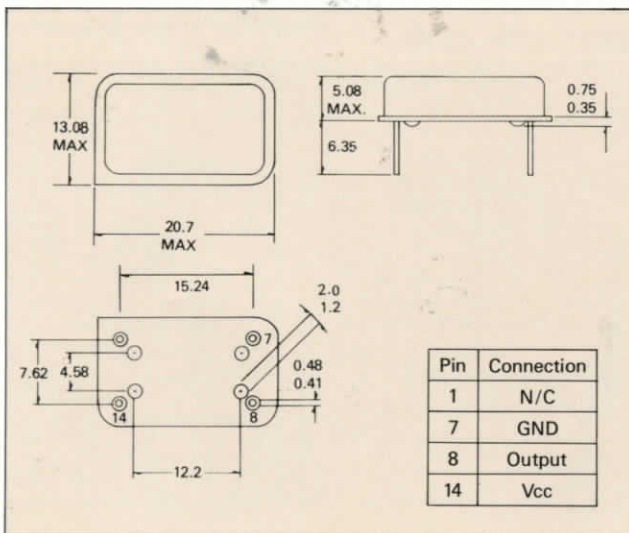

### TEST CIRCUITS

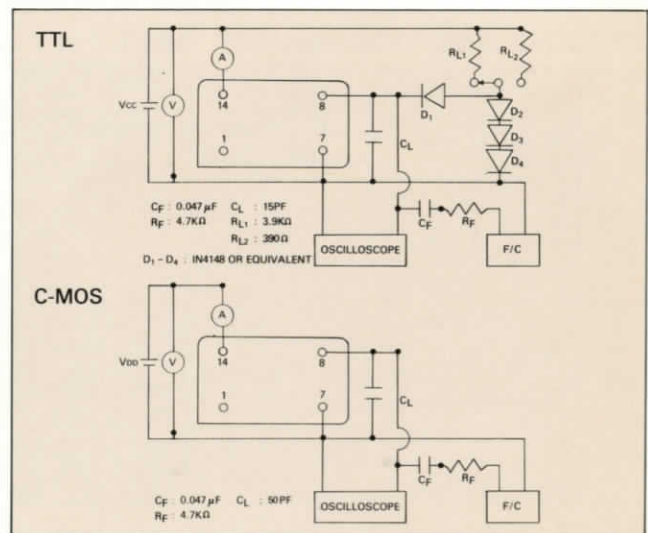

### OUTPUT WAVE FORM

#### TTL OUTPUT

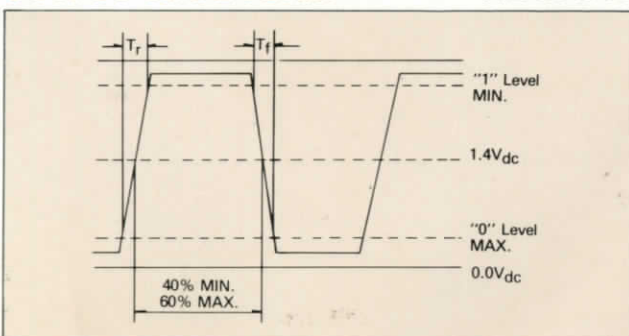

#### C-MOS OUTPUT

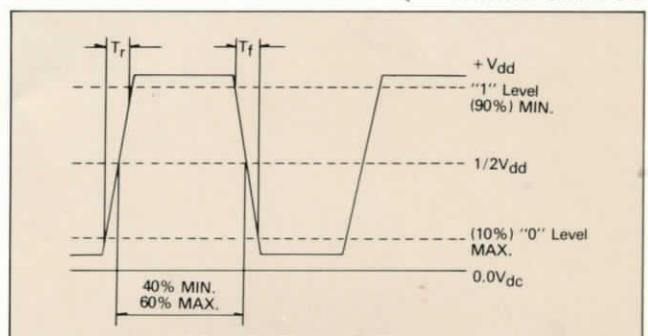

# CRYSTAL OSCILLATORS

## Features

- Dual (two) output frequency oscillator
- Compatible with 14-pin dual in line
- Drive C-MOS or TTL IC without analog design
- Cost and space savings
- Hermetically sealed metal case and high reliability

Model	SCO-031	SCO-034	SCO-037
Frequency range	0.256~75 MHz	0.256~60 MHz	
Frequency stability*	±25~±1000 PPM		
Operating temperature range	0°C~70°C		
Storage temperature range	-55°C~125°C		
Input voltage	5.0V DC ±5%	5.0V DC ±10%	
Input current	90 mA Max.	40 mA Max.	
Output	Symmetry	50% ±10% (at 1.4V)	50% ±10% (at 1/2 V <sub>DD</sub> )
	Rise/Fall time	15ns Max. (0.256~4 MHz), 10ns Max. (4~25 MHz), 5ns (25~75 MHz)	
	Fanout	1 to 10 TTL gates	1 TTL gate
Remark	Regarding to output frequency Pin 1, Pin 2 is irrespective of any frequency		pin 1; Fo/2 <sup>n</sup> pin 8: Fo

\*Inclusive of calibration tolerance at 25°C, operating temperature, input voltage change, load change, aging, shock and vibration.

## SCO-030 Series

### GENERAL SPECIFICATIONS



### OUTLINE AND DIMENSIONS (MM)

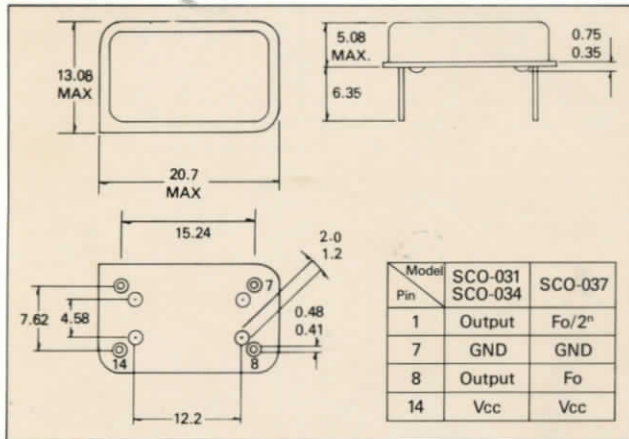

### TEST CIRCUITS

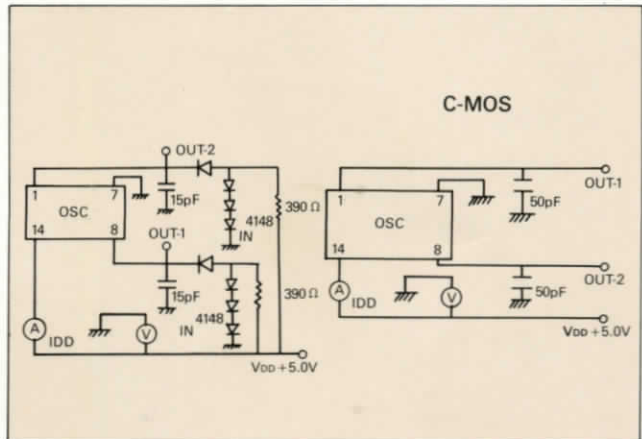

### OUTPUT WAVEFORM

#### TTL OUTPUT

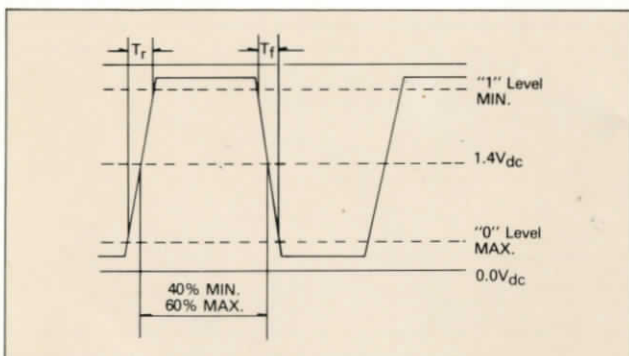

#### C-MOS OUTPUT

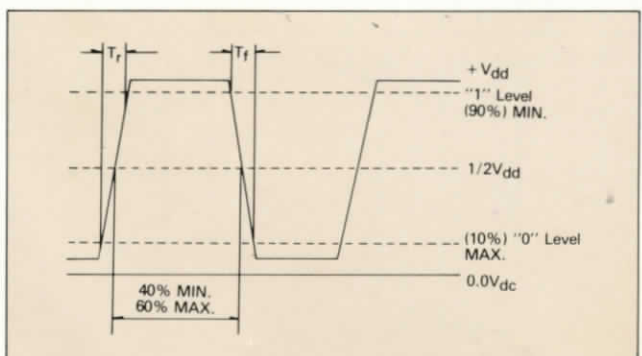

# CRYSTAL OSCILLATORS

## Features

- Compatible with 8-pin dual in line
- Drives C-MOS and TTL IC without analog design
- Low power consumption
- Cost and space savings
- Hermetically sealed metal case and high reliability

Model	SCO-061	SCO-062	SCO-063
Frequency range	3.5~75 MHz	0.256~20 MHz	0.256~60 MHz
Frequency stability*	±25~±1000 ppm		
Operating temperature range	0°C~70°C		
Storage temperature range	-55°C~125°C		
Input voltage	5.0V DC ±10%		
Input current	40mA Max. (3.5~25 MHz) 70mA Max (25~75 MHz)	25mA Max	15mA Max. (0.256~25 MHz) 30mA Max (25~60 MHz)
Output	Symmetry	50% ±10% (at 1.4V)	50% ±10% (at 1/2 V <sub>DD</sub> )
	Rise/Fall time	10ns Max (3.5~25 MHz) 5ns Max (25~75 MHz)	15ns Max
	Fanout	1 to 10 TTL gates	1 TTL gate
Remark	TTL	C-MOS	TTL AND C-MOS Compatibles

\*Inclusive of calibration tolerance at 25°C, operating temperature, input voltage change, load change, aging, shock and vibration.

## SCO-060 Series

### GENERAL SPECIFICATIONS

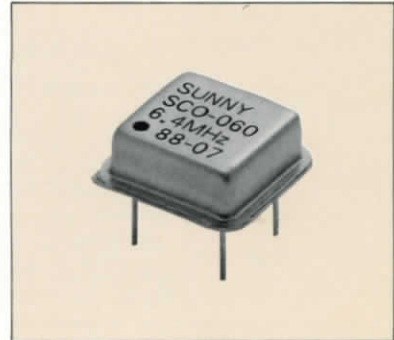

### OUTLINE AND DIMENSIONS (MM)

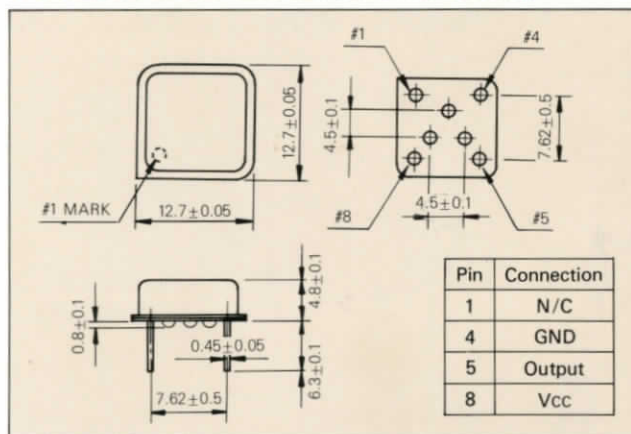

### TEST CIRCUITS

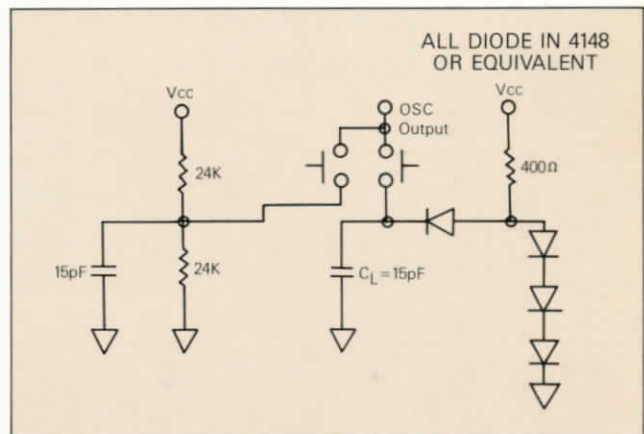

### OUTPUT WAVE FORM

#### TTL OUTPUT

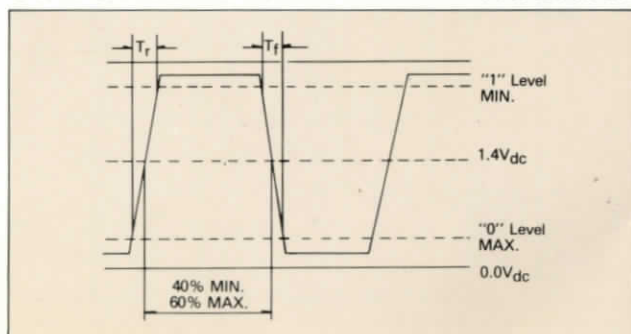

#### C-MOS OUTPUT

