

## NMC27C16 16,384-Bit (2048 × 8) UV Erasable CMOS PROM

### General Description

The NMC27C16 is a high speed 16k UV erasable and electrically reprogrammable EPROM ideally suited for applications where fast turn-around and pattern experimentation are important requirements.

The NMC27C16 is packaged in a 24-pin dual-in-line package with transparent lid. The transparent lid allows the user to expose the chip to ultraviolet light to erase the bit pattern. A new pattern can then be written into the device by following the programming procedure.

This ERPOM is fabricated with the reliable, high volume, time proven, CMOS silicon gate technology.

### Features

- 2048 × 8 organization
- Low power during programming
- Access time—450 ns
- Single 5V power supply
- Static—no clocks required
- Inputs and outputs TTL compatible during both read and program modes
- TRI-STATE® output

### Block and Connection Diagrams\*

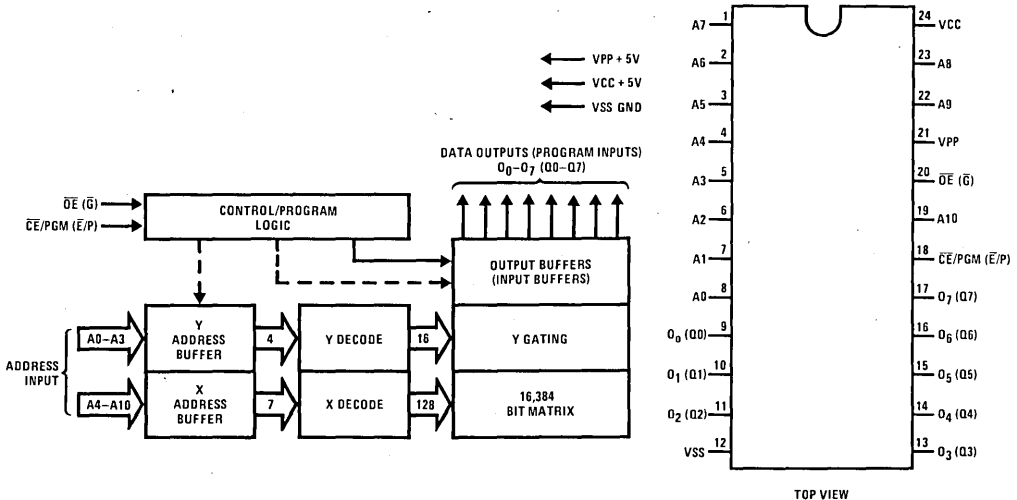

### Pin Connection During Read or Program

Mode	Pin Name/Number				
	CE/PGM (E/P) 18	OE (G) 20	VPP 21	VCC 24	Outputs 9-11, 13-17
Read	VIL	VIL	5	5	DOUT
Program	Pulsed VIL to VIH	VIH	25	5	DIN

### Pin Names

A0-A10	Address Inputs
O0-O7 (Q0-Q7)	Data Outputs
CE/PGM (E/P)	Chip Enable/Program
OE (G)	Output Enable
VPP	Read 5V, Program 25V
VCC	Power 5V
VSS	Ground

\* Symbols in parentheses are proposed industry standard.

## Absolute Maximum Ratings (Note 1)

Temperature Under Bias	- 25°C to + 85°C
Storage Temperature	- 65°C to + 125°C
VPP Supply Voltage with Respect to VSS	26.5V to - 0.3V
All Input or Output Voltages with Respect to VSS (except VPP)	VCC + 0.3V to - 0.3V
Power Dissipation	1.5W
Lead Temperature (Soldering, 10 seconds)	300°C

## READ OPERATION

**DC Operating Characteristics** TA = 0°C to + 70°C, VCC = 5V ± 5%, (VCC = 5V ± 10% for NMC27C16-1), VPP = VCC ± 0.6V (Note 3), VSS = 0V, unless otherwise noted.

Symbol	Parameter	Conditions	Min	Typ	Max	Units
ILI	Input Current	VIN = 5.25V or VIN = VIL			10	μA
ILO	Output Leakage Current	VOUT = 5.25V, $\overline{CE}/PGM = 5V$			10	μA
IPP1	VPP Supply Current	VPP = 5.85V			5	mA
ICC1	VCC Supply Current (Standby)	$\overline{CE}/PGM = VIH, \overline{OE} = VIL$		10	25	mA
ICC2	VCC Supply Current (Active)	$\overline{CE}/PGM = \overline{OE} = VIL$		57	100	mA
VIL	Input Low Voltage		- 0.1		0.8	V
VIH	Input High Voltage		2.0		VCC + 1	V
VOH	Output High Voltage	IOH = - 400 μA	2.4			V
VOL	Output Low Voltage	IOL = 2.1 mA			0.45	V

**AC Characteristics** (Note 2) TA = 0°C to + 70°C, VCC = 5V ± 5%, (VCC = 5V ± 10% for NMC27C16-1), VPP = VCC ± 0.6V (Note 3), VSS = 0V, unless otherwise noted.

Symbol		Parameter	Conditions	NMC27C16		NMC27C16-1		NMC27C16-2		Units
Alternate	Standard			Min	Max	Min	Max	Min	Max	
t <sub>ACC</sub>	TAVQV	Address to Output Delay	$\overline{CE}/PGM = \overline{OE} = VIL$		450		350		390	ns
t <sub>CE</sub>	TELQV	$\overline{CE}$ to Output Delay	$\overline{OE} = VIL$		450		350		390	ns
t <sub>OE</sub>	TGLQV	Output Enable to Output Delay	$\overline{CE}/PGM = VIL$		120		120		120	ns
t <sub>DF</sub>	TGHQZ	Output Enable High to Output Hi-Z	$\overline{CE}/PGM = VIL$	0	100	0	100	0	100	ns
t <sub>OH</sub>	TAXQX	Address to Output Hold	$\overline{CE}/PGM = \overline{OE} = VIL$	0		0		0		ns
t <sub>OD</sub>	TEHQZ	$\overline{CE}$ to Output Hi-Z	$\overline{OE} = VIL$	0	100	0	100	0	100	ns

**Capacitance** TA = 25°C, f = 1 MHz

Symbol	Parameter	Conditions	Typ	Max	Units
CI	Input Capacitance	VIN = 0V	4	6	pF
CO	Output Capacitance	VOUT = 0V	8	12	pF

### AC Test Conditions

Output Load: 1 TTL gate and CL = 100 pF  
Input Rise and Fall Times: ≤ 20 ns

**Note 1:** "Absolute Maximum Ratings" are those values beyond which the safety of the device cannot be guaranteed. Except for "Operating Temperature Range" they are not meant to imply that the devices should be operated at these limits. The table of "Electrical Characteristics" provides conditions for actual device operation.

**Note 2:** Typical conditions are for operation at: TA = 25°C, VCC = 5V, VPP = VCC, and VSS = 0V.

**Note 3:** VPP may be connected to VCC except during program. The ± 0.6V tolerance allows a circuit to switch VPP between the read voltage and the program voltage.

**Note 4:** Capacitance is guaranteed by periodic testing. TA = 25°C, f = 1 MHz.

Switching Time Waveforms \*

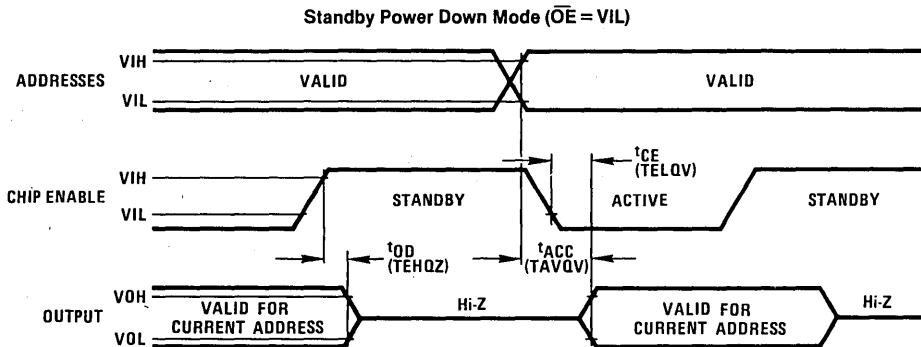
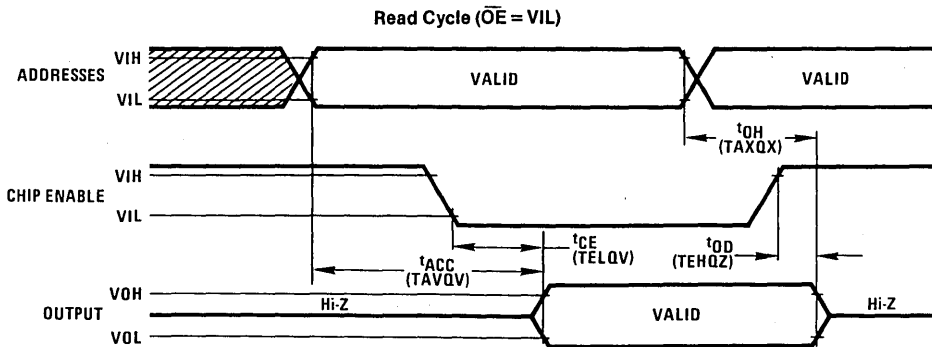
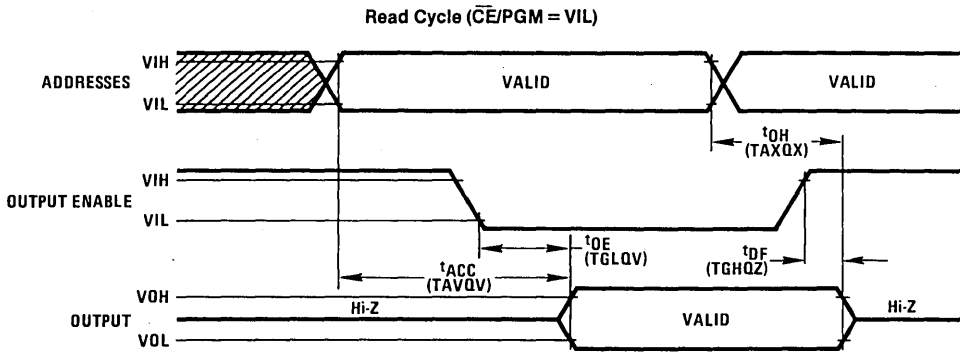

\* Symbols in parentheses are proposed industry standard.

## PROGRAM OPERATION

### DC Electrical Characteristics and Operating Conditions (Notes 1 and 2)

(TA = 25°C ± 5°C) (VCC = 5V ± 5%, VPP = 25V ± 1V)

Symbol	Parameter	Min	Typ	Max	Units
ILI	Input Leakage Current (Note 3)			10	μA
VIL	Input Low Level	-0.1		0.8	V
VIH	Input High Level	2.0		VCC + 1	V
ICC	VCC Power Supply Current			100	mA
IPP1	VPP Supply Current (Note 4)			5	mA
IPP2	VPP Supply Current During Programming Pulse (Note 5)			30	mA

### AC Characteristics and Operating Conditions (Notes 1, 2, and 6)

(TA = 25°C ± 5°C) (VCC = 5V ± 5%, VPP = 25V ± 1V)

Symbol		Parameter	Min	Typ	Max	Units
Alternate	Standard					
t <sub>AS</sub>	TAVPH	Address Set-up Time	2			μs
t <sub>OS</sub>	TGHPH	$\overline{OE}$ Set-up Time	2			μs
t <sub>DS</sub>	TDVPH	Data Set-up Time	2			μs
t <sub>AH</sub>	TPLAX	Address Hold Time	2			μs
t <sub>OH</sub>	TPLGX	$\overline{OE}$ Hold Time	2			μs
t <sub>DH</sub>	TPLDX	Data Hold Time	2			μs
t <sub>DF</sub>	TGHQZ	Chip Disable to Output Float Delay (Note 4)	0		130	ns
t <sub>CE</sub>	TGLQV	Chip Enable to Output Delay (Note 4)			150	ns
t <sub>PW</sub>	TPHPL	Program Pulse Width	45	50	55	ms
t <sub>PR</sub>	TPH1PH2	Program Pulse Rise Time	5			ns
t <sub>PF</sub>	TPL2PL1	Program Pulse Fall Time	5			ns

**Note 1:** VCC must be applied at the same time or before VPP and removed after or at the same time as VPP. To prevent damage to the device it must not be inserted into a board with power applied.

**Note 2:** Care must be taken to prevent overshoot of the VPP supply when switching to +25V.

**Note 3:**  $0.45V \leq V_{IN} \leq 5.25V$

**Note 4:**  $\overline{CE}/PGM = V_{IL}$ , VPP = VCC

**Note 5:** VPP = 26V

**Note 6:** Transition times  $\leq 20$  ns unless noted otherwise.

Timing Diagram \*

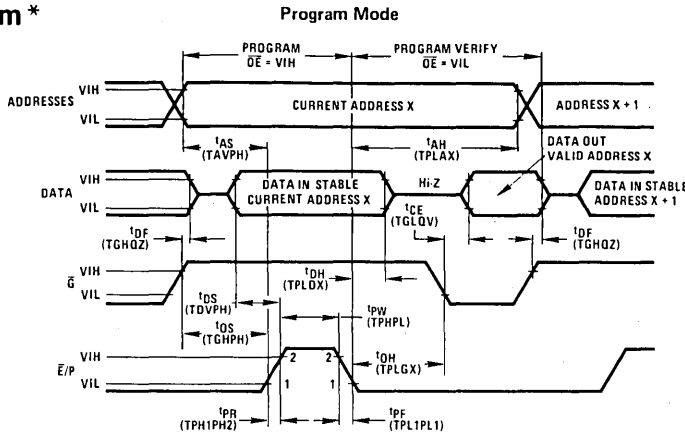

Functional Description

DEVICE OPERATION

The NMC27C16 has 3 modes of operation in the normal system environment. These are shown in Table I.

Read Mode

The NMC27C16 read operation requires that  $\overline{OE} = VIL$ ,  $\overline{CE}/PGM = VIL$  and that addresses A0-A10 have been stabilized. Valid data will appear on the output pins after  $t_{ACC}$ ,  $t_{OE}$  or  $t_{CE}$  times (see Switching Time Waveforms) depending on which is limiting.

Deselect Mode

The NMC27C16 is deselected by making  $\overline{OE} = VIH$ . This mode is independent of  $\overline{CE}/PGM$  and the condition of the addresses. The outputs are Hi-Z when  $\overline{OE} = VIH$ . This allows OR-tying 2 or more NMC27C16's for memory expansion.

Standby Mode (Power Down)

The NMC27C16 may be powered down to the standby mode by making  $\overline{CE}/PGM = VIH$ . This is independent of  $\overline{OE}$  and automatically puts the outputs in their Hi-Z state. The power is reduced to 25% (132 mW max) of the normal operating power. VCC and VPP must be maintained at 5V. Access time at power up remains either  $t_{ACC}$  or  $t_{CE}$  (see Switching Time Waveforms).

PROGRAMMING

The NMC27C16 is shipped from National completely erased. All bits will be at a "1" level (output high) in this initial state and after any full erasure. Table II shows the 3 programming modes.

TABLE I. OPERATING MODES (VCC = VPP = 5V)

Mode	Pin Name/Number		
	$\overline{CE}/PGM$ ( $\overline{E}/P$ ) 18	$\overline{OE}$ ( $\overline{G}$ ) 20	Outputs 9-11, 13-17
Read	VIL	VIL	DOUT
Deselect	Don't Care	VIH	Hi-Z
Standby	VIH	Don't Care	Hi-Z

TABLE II. PROGRAMMING MODES (VCC = 5V)

Mode	Pin Name/Number			
	$\overline{CE}/PGM$ ( $\overline{E}/P$ ) 18	$\overline{OE}$ ( $\overline{G}$ ) 20	VPP 21	Outputs Q 9-11, 13-17
Program	Pulsed VIL to VIH	VIH	25	DIN
Program Verify	VIL	VIL	25(5)	DOUT
Program Inhibit	VIL	VIH	25	Hi-Z

\* Symbols in parentheses are proposed industry standard

## Functional Description (Continued)

### Program Mode

The NMC27C16 is programmed by introducing "0"s into the desired locations. This is done 8 bits (a byte) at a time. Any individual address, a sequence of addresses, or addresses chosen at random may be programmed. Any or all of the 8 bits associated with an address location may be programmed with a single program pulse applied to the chip enable pin. All input voltage levels, including the program pulse on chip enable are TTL compatible. The programming sequence is:

With  $V_{PP} = 25V$ ,  $V_{CC} = 5V$ ,  $\overline{OE} = V_{IH}$  and  $\overline{CE}/PGM = V_{IL}$ , an address is selected and the desired data word is applied to the output pins. ( $V_{IL} = "0"$  and  $V_{IL} = "1"$  for both address and data.) After the address and data signals are stable the program pin is pulsed from  $V_{IL}$  to  $V_{IH}$  with a pulse width between 45 ms and 55 ms.

Multiple pulses are not needed but will not cause device damage. No pins should be left open. A high level ( $V_{IH}$  or higher) *must not* be maintained longer than  $t_{PW(MAX)}$  on the program pin during programming. NMC27C16s may be programmed in parallel with the same data in this mode.

### Program Verify Mode

The programming of the NMC27C16 may be verified either 1 word at a time during the programming (as shown in the timing diagram) or by reading all of the words out at the end of the programming sequence. This can be done with  $V_{PP} = 25V$  (or 5V) in either case.

### Program Inhibit Mode

The program inhibit mode allows programming several NMC27C16s simultaneously with different data for each one by controlling which ones receive the program pulse. All similar inputs of the NMC27C16 may be paralleled. Pulsing the program pin (from  $V_{IL}$  to  $V_{IH}$ ) will program a

unit while inhibiting the program pulse to a unit will keep it from being programmed and keeping  $\overline{OE} = V_{IH}$  will put its outputs in the Hi-Z state.

### ERASING

The NMC27C16 is erased by exposure to high intensity ultraviolet light through the transparent window. This exposure discharges the floating gate to its initial state through induced photo current. It is recommended that the NMC27C16 be kept out of direct sunlight. The UV content of sunlight may cause a partial erasure of some bits in a relatively short period of time. Direct sunlight can also cause temporary functional failure. Extended exposure to room level fluorescent lighting will also cause erasure. An opaque coating (paint, tape, label, etc.) should be placed over the package window if this product is to be operated under these lighting conditions.

An ultraviolet source of 2537Å yielding a total integrated dosage of 15 watt-seconds/cm<sup>2</sup> is required. This will erase the part in approximately 15 to 20 minutes if a UV lamp with a 12,000 μW/cm<sup>2</sup> power rating is used. The NMC27C16 to be erased should be placed 1 inch away from the lamp and no filters should be used.

An erasure system should be calibrated periodically. The distance from lamp to unit should be maintained at 1 inch. The erasure time is increased by the square of the distance (if the distance is doubled the erasure time goes up by a factor of 4). Lamps lose intensity as they age. When a lamp is changed, the distance is changed, or the lamp is aged, the system should be checked to make certain full erasure is occurring. Incomplete erasure will cause symptoms that can be misleading. Programmers, components, and system designs have been erroneously suspected when incomplete erasure was the basic problem.