

1. Description

The LM2596 /LM2596HV series of regulators are monolithic integrated circuits that provide all the active functions for a step-down (buck) switching regulator, capable of driving a 3A load with excellent line and load regulation. These devices are available in fixed output voltages of 3.3V, 5V, 12V, and an adjustable output version.

Requiring a minimum number of external components, these regulators are simple to use and include internal frequency compensation, and a fixed-frequency oscillator.

The LM2596 /LM2596HV series operates at a switching frequency of 150 kHz thus allowing smaller sized filter components than what would be needed with lower frequency switching regulators. Available in a standard 5-lead TO-220 package with several different lead bend options, and a 5-lead TO-262 surface mount package.

3. Applications

- Simple high-efficiency step-down (buck) regulator
- On-card switching regulators

2. Features

- 3.3V, 5V, 12V, and adjustable output versions
 - Adjustable version output voltage range, 1.2V to 37V (57V for HV version)
 - $\pm 4\%$ max over line and load conditions
 - Available in TO-220 and TO-263, TO-220B packages
 - Guaranteed 3A output load current
 - Input voltage range up to 60V
 - Requires only 4 external components
 - Excellent line and load regulation specifications
 - 150 kHz fixed frequency internal oscillator
 - TTL shutdown capability
 - Low power standby mode, IQ typically 80 μ A
 - High efficiency
 - Uses readily available standard inductors
 - Thermal shutdown and current limit protection
-
- Positive to negative converter
 - Note: Patent Number 5,382,918.



4. Typical Application (Fixed Output Voltage Versions)

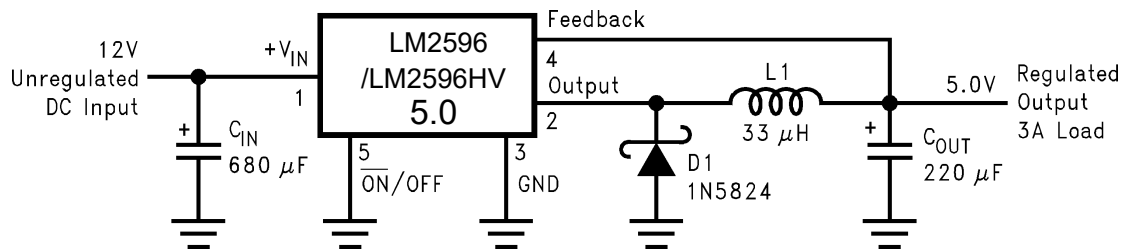

5. Package Types



TO220B-5L

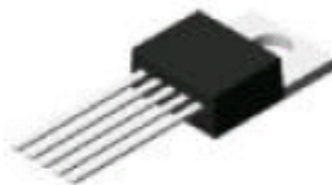

TO220-5L

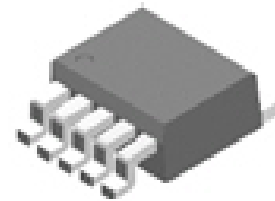

TO263-5L



6. Pinning information

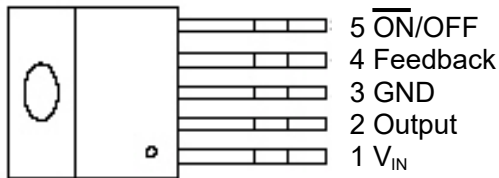

TO220B-5L/TO220-5L

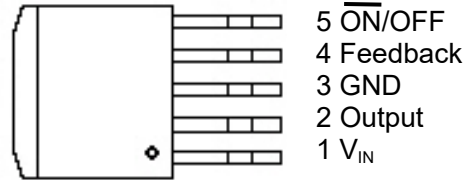

TO263-5L

Pin Descriptions

Name	Description
V_{IN}	Input supply voltage
Output	Switching output
GND	Ground
Feedback	Output voltage feedback
ON/OFF	ON/OFF shutdown Active is "Low" or floating

7. Ordering information

Temperature Range	Output Voltage, V				Package Type
	3.3	5.0	12	ADJ	
$-40^{\circ}\text{C} \leq T_A \leq 125^{\circ}\text{C}$	LM2596HVS - 3.3	LM2596HVS - 5.0	LM2596HVS - 12	LM2596HVS - ADJ	TO-263
	LM2596S - 3.3	LM2596S - 5.0	LM2596S - 12	LM2596S - ADJ	
	LM2596HVT - 3.3	LM2596HVT - 5.0	LM2596HVT - 12	LM2596HVT - ADJ	TO-220
	LM2596T - 3.3	LM2596T - 5.0	LM2596T - 12	LM2596T - ADJ	



8. Absolute Maximum Ratings (Note 1)

Parameter	Rating
Maximum Supply Voltage	
LM2596	45V
LM2596HV	63V
$\overline{\text{ON}}$ /OFF Pin Input Voltage	$-0.3 \leq V \leq +25V$
Feedback Pin Voltage	$-0.3 \leq V \leq +25V$
Output Voltage to Ground (Steady State)	-1V
Power Dissipation	Internally limited
Storage Temperature Range	-65°C to +150°C
ESD Susceptibility HumanBodyModel	2kV
Vapor Phase (60 sec.)	+215°C
Infrared (10 sec.)	+245°C
T Package (Soldering, 10 sec.)	+260°C
Maximum Junction Temperature	+150°C

9. Operating Conditions

Parameter	Rating
Temperature Range	$-40^{\circ}\text{C} \leq T_J \leq +125^{\circ}\text{C}$
Supply Voltage	
LM2596	4.75V ~ 40V
LM2596HV	4.75V ~ 60V



10.1 Electrical Characteristics

Specifications with standard type face are for $T_J=25^\circ\text{C}$, and those with boldface type apply over full Operating Temperature Range

Parameter	Symbol	Conditions	Typ	Limit	Units
System Parameters (Note 5) Test Circuit Figure 1 (LM2596 - 3.3, LM2596HV-3.3)					
Output Voltage	V_{OUT}	$4.75\text{V} \leq V_{\text{IN}} \leq 40\text{V}$ (60V) $0.2\text{A} \leq I_{\text{LOAD}} \leq 3\text{A}$	3.3		V
				3.168/3.135	V(min)
				3.432/3.465	V(max)
Efficiency	η	$V_{\text{IN}}=12\text{V}$, $I_{\text{LOAD}}=3\text{A}$	73		%
System Parameters (Note 5) Test Circuit Figure 1 (LM2596-5.0, LM2596HV-5.0)					
Output Voltage	V_{OUT}	$7\text{V} \leq V_{\text{IN}} \leq 40\text{V}$ (60V) $0.2\text{A} \leq I_{\text{LOAD}} \leq 3\text{A}$	5		V
				4.800/4.750	V(min)
				5.200/5.250	V(max)
Efficiency	η	$V_{\text{IN}}=12\text{V}$, $I_{\text{LOAD}}=3\text{A}$	80		%
System Parameters (Note 5) Test Circuit Figure 1 (LM2596-12, LM2596HV-12)					
Output Voltage	V_{OUT}	$15\text{V} \leq V_{\text{IN}} \leq 40\text{V}$ (60V) $0.2\text{A} \leq I_{\text{LOAD}} \leq 3\text{A}$	12		V
				11.52/11.40	V(min)
				12.48/12.60	V(max)
Efficiency	η	$V_{\text{IN}}=25\text{V}$, $I_{\text{LOAD}}=3\text{A}$	90		%
System Parameters (Note 5) Test Circuit Figure 1 (LM2596-ADJ, LM2596HV-ADJ)					
Feedback Voltage	V_{FB}	$4.5\text{V} \leq V_{\text{IN}} \leq 40\text{V}$ (57V) $0.2\text{A} \leq I_{\text{LOAD}} \leq 3\text{A}$, V_{OUT} programmed for 3V. Circuit of Figure 1.	1.23		V
				1.193/1.180	V(min)
				1.267/1.280	V(max)
Efficiency	η	$V_{\text{IN}}=12\text{V}$, $V_{\text{OUT}}=3\text{V}$, $I_{\text{LOAD}}=3\text{A}$	73		%



10.2 Electrical Characteristics (All Output Voltage Versions)

Specifications with standard type face are for $T_J=25^\circ\text{C}$, and those with boldface type apply over full Operating Temperature Range, Unless otherwise specified, $V_{IN}=12\text{V}$ for the 3.3V, 5V, and Adjustable version and $V_{IN}=24\text{V}$ for the 12V version. $I_{LOAD}=500\text{mA}$

Parameter	Symbol	Conditions	Typ	Limit	Units
Device Parameters					
Feedback Bias Current	I_B	Adjustable Version Only $V_{FB}=1.3\text{V}$	10		nA
				50/100	nA(max)
Oscillator Frequency	f_o	(Note 6)	150		kHz
				117/117	kHz(min)
				183/183	kHz(max)
Saturation Voltage	V_{SAT}	$I_{OUT}=3\text{A}$ (Notes 7, 8)	1.16		V
				1.4/1.5	V(max)
Max Duty Cycle (ON)	DC	(Note 8)	100		%
Min Duty Cycle (OFF)		(Note 9)	0		%
Current Limit	I_{CL}	Peak Current (Notes 7, 8)	4.5		A
				3.6/3.4	A(min)
				6.9/7.5	A(max)
Output Leakage Current	I_L	Output=0V (Notes 7, 9)		50	μA (max)
		Output=-1V (Note 10)	2		mA
				30	mA(max)
Quiescent Current	I_Q	(Note 9)	5		mA
				10	mA(max)
Standby Quiescent Current	I_{STBY}	ON/OFF pin=5V (OFF)	80		μA
		(Note 10)		200/250	μA (max)



Parameter	Symbol	Conditions	Typ	Limit	Units
Thermal Resistance	θ_{JC}	TO-220 or TO-263 Package Junction to Case	2		$^{\circ}\text{C/W}$
	θ_{JA}	TO-220 Package, Junction to Ambient (Note 11)	50		$^{\circ}\text{C/W}$
	θ_{JA}	TO-263 Package, Junction to Ambient (Note 12)	50		$^{\circ}\text{C/W}$
	θ_{JA}	TO-263 Package, Junction to Ambient (Note 13)	30		$^{\circ}\text{C/W}$
	θ_{JA}	TO-263 Package, Junction to Ambient (Note 14)	20		$^{\circ}\text{C/W}$
ON/OFF CONTROL Test Circuit Figure 1					
ON/OFF Pin Logic Input Threshold Voltage	V_{IH} V_{IL}	Low (Regulator ON) High (Regulator OFF)	1.3		V
				0.6	V(max)
				2	V(min)
ON/OFF Pin Input Current	I_H	$V_{LOGIC}=2.5\text{V}$ (Regulator OFF)	5		μA
				15	$\mu\text{A(max)}$
	I_L	$V_{LOGIC}=0.5\text{V}$ (Regulator ON)	0.02		μA
				5	$\mu\text{A(max)}$

Note 1: Absolute Maximum Ratings indicate limits beyond which damage to the device may occur. Operating Ratings indicate conditions for which the device is intended to be functional, but do not guarantee specific performance limits. For guaranteed specifications and test conditions, see the Electrical Characteristics.

Note 2: The human body model is a 100 pF capacitor discharged through a 1.5k resistor into each pin.

Note 3: Typical numbers are at 25°C and represent the most likely norm.

Note 4: All limits guaranteed at room temperature (standard type face) and at temperature extremes (bold type face). All room temperature limits are 100% production tested. All limits at temperature extremes are guaranteed via correlation using standard Statistical Quality Control (SQC) methods. All limits are used to calculate Average Outgoing Quality Level (AOQL).

Note 5: External components such as the catch diode, inductor, input and output capacitors, and voltage programming resistors can affect switching regulator system performance. When the LM2596 is used as shown in the Figure 1 test circuit, system performance will be as shown in system parameters section of Electrical Characteristics.



Note 6: The switching frequency is reduced when the second stage current limit is activated.

Note 7: No diode, inductor or capacitor connected to output pin.

Note 8: Feedback pin removed from output and connected to 0V to force the output transistor switch ON.

Note 9: Feedback pin removed from output and connected to 12V for the 3.3V, 5V, and the ADJ. version, and 15V for the 12V version, to force the output transistor switch OFF.

Note 10: $V_{IN} = 40V$.

Note 11: Junction to ambient thermal resistance (no external heat sink) for the TO-220 package mounted vertically, with the leads soldered to a printed circuit board with (1 oz.) copper area of approximately 1 in².

Note 12: Junction to ambient thermal resistance with the TO-263 package tab soldered to a single printed circuit board with 0.5 in² of (1 oz.) copper area.

Note 13: Junction to ambient thermal resistance with the TO-263 package tab soldered to a single sided printed circuit board with 2.5 in² of (1 oz.) copper area.

Note 14: Junction to ambient thermal resistance with the TO-263 package tab soldered to a double sided printed circuit board with 3 in² of (1 oz.) copper area on the LM2596S side of the board, and approximately 16 in² of copper on the other side of the p-c board. See Application Information in this data sheet and the thermal model in Switchers Made Simple™ version 4.3 software.



11.1 Typical Characteristic (Circuit of Figure 1)

<p>Output Voltage Change (%)</p> <p>$V_{IN} = 20V$ $I_{LOAD} = 3A$ Normalized at $T_J = 25^\circ C$</p> <p>Junction Temperature ($^\circ C$)</p>	<p>Output Voltage Change (%)</p> <p>$V_{OUT} = 5V$ $I_{LOAD} = 100 mA$ $T_J = 25^\circ C$</p> <p>Input Voltage (V)</p>
<p>Figure 1: Normalized Output Voltage</p>	<p>Figure 2: Line Regulation</p>
<p>Efficiency (%)</p> <p>3A Load</p> <p>20V 12V 5V 3.3V</p> <p>Input Voltage (V)</p>	<p>Saturation Voltage (V)</p> <p>$V_{IN} = 12V$</p> <p>$T_J = -40^\circ C$ $25^\circ C$ $125^\circ C$</p> <p>Switch Current (A)</p>
<p>Figure 3: Efficiency</p>	<p>Figure 4: Switch Saturation Voltage</p>
<p>Switch Current Limit (A)</p> <p>$V_{IN} = 12V$ $V_{OUT} = 5V$</p> <p>Junction Temperature ($^\circ C$)</p>	<p>Input-Output Differential (V)</p> <p>$L = 33 \mu H$ $R_{IND} = 0.04 \Omega$ $V_{OUT} = V_{REG} - 50 mV$ $I_{LOAD} = 3A$ $I_{LOAD} = 1A$</p> <p>Junction Temperature ($^\circ C$)</p>
<p>Figure 5: Switch Current Limit</p>	<p>Figure 6: Dropout Voltage</p>



11.2 Typical Characteristic

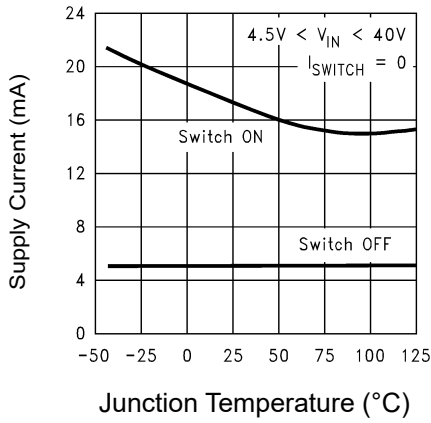

Figure 7: Quiescent Current

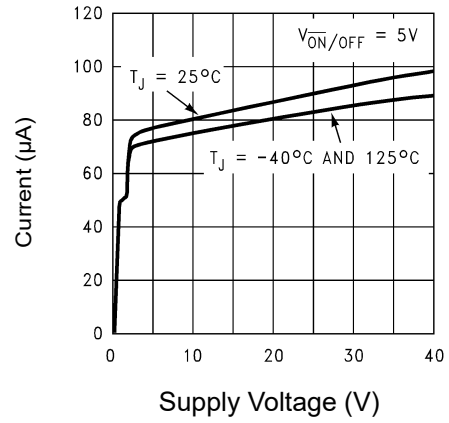

Figure 8: Quiescent Current

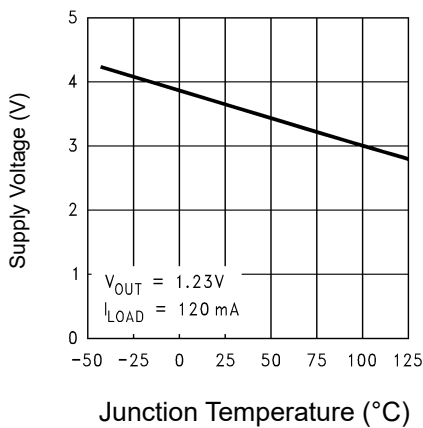

Figure 9: Supply Voltage

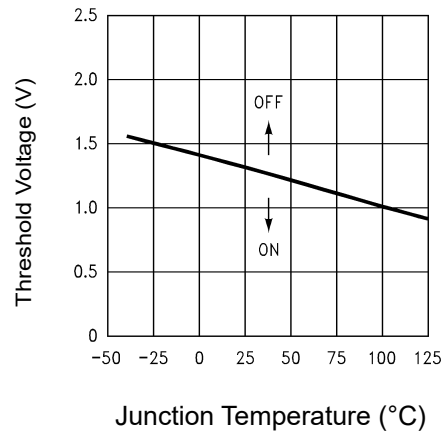

Figure 10: $\overline{\text{ON/OFF}}$ Threshold Voltage

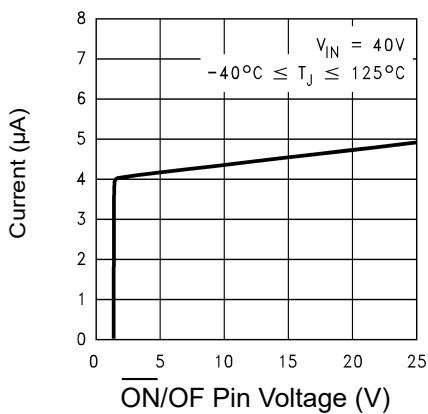

Figure 11: $\overline{\text{ON/OFF}}$ Pin Current (Sinking)

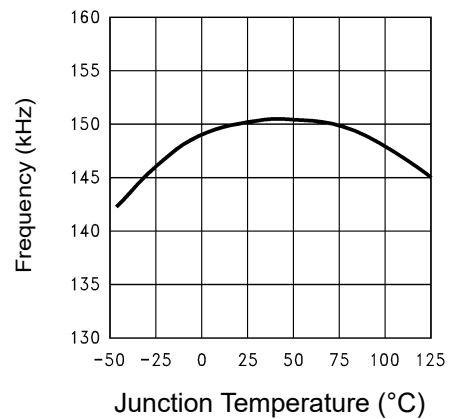

Figure 12: Switching Frequency



12.Series Buck Regulator Design Procedure (Fixed Output) (Continued)

Conditions			Inductor		Output Capacitor			
					Through Hole Electrolytic		Surface Mount Tantalum	
Output Voltage (V)	Load Current (A)	Max Input Voltage (V)	Inductance (μH)	Inductor (#)	Panasonic HFQ Series (μF/V)	Nichicon PL Series (μF/V)	AVX TPS Series (μF/V)	Sprague 595D Series (μF/V)
3.3	3	5	22	L41	470/25	560/16	330/6.3	390/6.3
		7	22	L41	560/35	560/35	330/6.3	390/6.3
		10	22	L41	680/35	680/35	330/6.3	390/6.3
	2	40	33	L40	560/35	470/35	330/6.3	390/6.3
		6	22	L33	470/25	470/35	330/6.3	390/6.3
		10	33	L32	330/35	330/35	330/6.3	390/6.3
5	3	40	47	L39	330/35	270/50	220/10	330/10
		8	22	L41	470/25	560/16	220/10	330/10
		10	22	L41	560/25	560/25	220/10	330/10
	2	15	33	L40	330/35	330/35	220/10	330/10
		40	47	L39	330/35	270/35	220/10	330/10
		9	22	L33	470/25	560/16	220/10	330/10
12	3	20	68	L38	180/35	180/35	100/10	270/10
		40	68	L38	180/35	180/35	100/10	270/10
		15	22	L41	470/25	470/25	100/16	180/16
	2	18	33	L40	330/25	330/25	100/16	180/16
		30	68	L44	180/25	180/25	100/16	120/20
		40	68	L44	180/35	180/35	100/16	120/20
2	15	33	L32	330/25	330/25	100/16	180/16	
	20	68	L38	180/25	180/25	100/16	120/20	
	40	150	L42	82/25	82/25	68/20	68/25	

Figure 2. LM2596 Fixed Voltage Quick Design Component Selection Table



13. Series Buck Regulator Desing Procedure (Adjustable Output)

Output Voltage (V)	Through Hole Output Capacitor			Surface Mount Output Capacitor		
	Panasonic HFQ Series ($\mu\text{F}/\text{V}$)	Nichicon PL Series ($\mu\text{F}/\text{V}$)	Feedforward capacitor	AVX TPS Series ($\mu\text{F}/\text{V}$)	Sprague 595D Series ($\mu\text{F}/\text{V}$)	Feedforward Capacitor
2	820/35	820/35	33nF	330/6.3	470/4	33nF
4	560/35	470/35	10nF	330/6.3	390/6.3	10nF
6	470/25	470/25	3.3nF	220/10	330/10	3.3nF
9	330/25	330/25	1.5nF	100/16	180/16	1.5nF
12	330/25	330/25	1nF	100/16	180/16	1nF
15	220/35	220/35	680pF	68/20	120/20	680pF
24	220/35	150/35	560pF	33/25	33/25	220pF
28	100/50	100/50	390pF	10/35	15/50	220pF

Figure 3. Output Capacitor and Feedforward Capacitor Selection Table



14. Series Buck Regulator Design Procedure

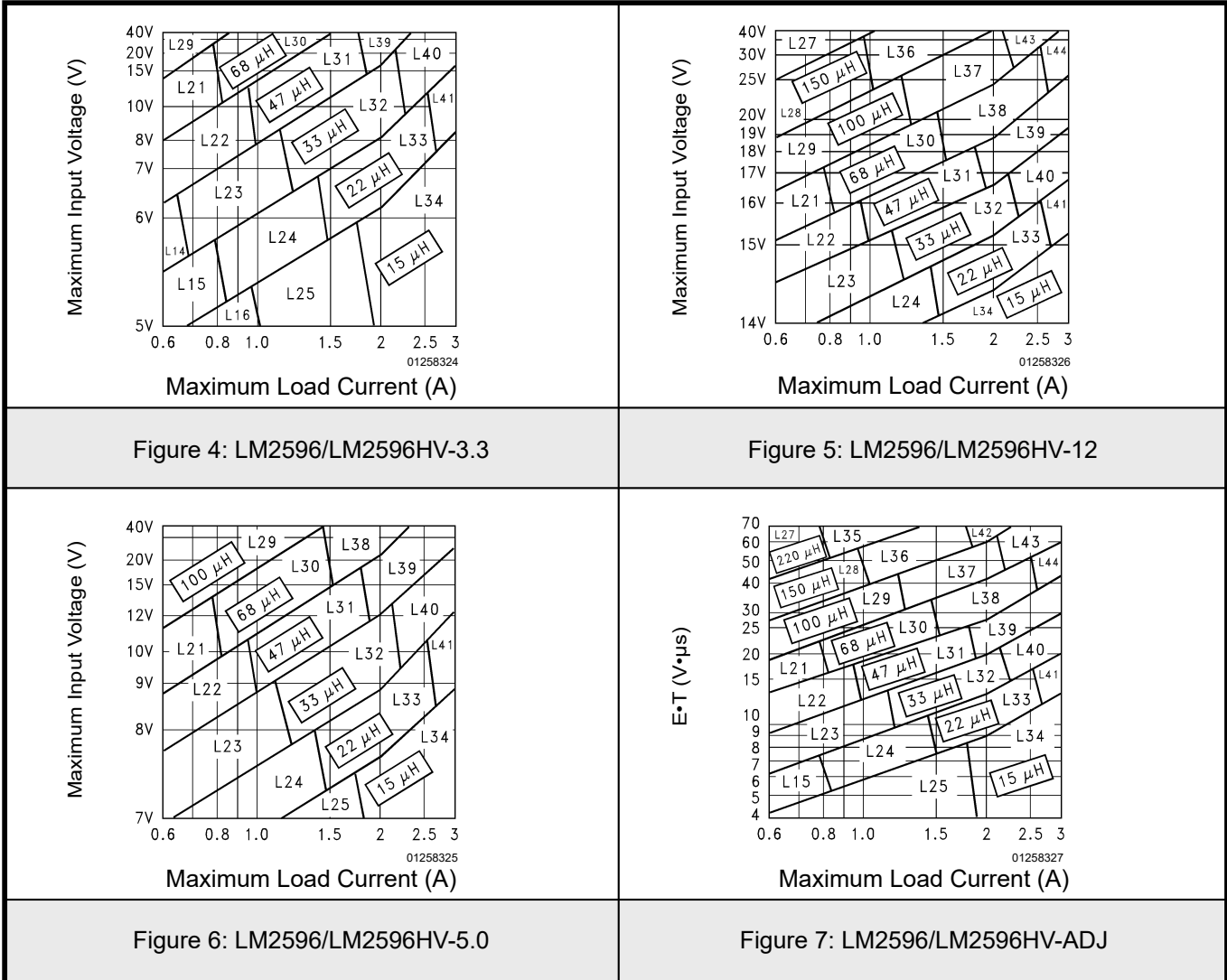



15. Test Circuit and Layout Guidelines (Continued)

Adjustable Output Voltage Versions

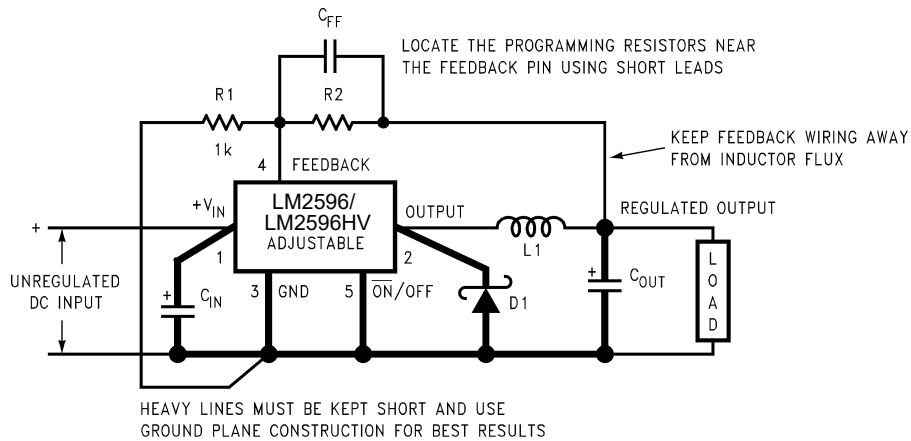

$$V_{OUT} = V_{REF} (1 + R_2/R_1)$$

where $V_{REF} = 1.23V$

$$R_2 = R_1 (V_{OUT}/V_{REF} - 1)$$

Select R_1 to be approximately 1 k Ω , use a 1% resistor for best stability.

C_{IN} — 470 μF , 50V, Aluminum Electrolytic Nichicon “PL Series”

C_{OUT} — 220 μF , 35V Aluminum Electrolytic, Nichicon “PL Series”

D1 — 5A, 40V Schottky Rectifier, 1N5825

L1 — 68 μH , L38

R1 — 1 k Ω , 1%

C_{FF} — See Application Information Section

Figure 1. Standard Test Circuits and Layout Guides



As in any switching regulator, layout is very important. Rapidly switching currents associated with wiring inductance can generate voltage transients which can cause problems. For minimal inductance and ground loops, the wires indicated by heavy lines should be wide printed circuit traces and should be kept as short as possible. For best results, external components should be located as close to the switcher IC as possible using ground plane construction or single point grounding.

If open core inductors are used, special care must be taken as to the location and positioning of this type of inductor. Allowing the inductor flux to intersect sensitive feedback, IC groundpath and C_{OUT} wiring can cause problems.

When using the adjustable version, special care must be taken as to the location of the feedback resistors and the associated wiring. Physically locate both resistors near the IC, and route the wiring away from the inductor, especially an open core type of inductor. (See application section for more information.)



16. Series Buck Regulator Design Procedure (Adjustable Output)

Procedure (Adjustable Output Voltage Version)

Given:

V_{OUT} =Regulated Output Voltage

$V_{IN(max)}$ =Maximum Input Voltage

$I_{LOAD(max)}$ =Maximum Load Current

F=Switching Frequency (Fixed at a nominal 150 kHz).

1. Programming Output Voltage (Selecting R_1 and R_2 , as shown in Figure 1)

Use the following formula to select the appropriate resistor values.

$$V_{OUT}=V_{REF}(1+R_2/R_1) \text{ where } V_{REF}=1.23V$$

Select a value for R_1 between 240 Ω and 1.5k Ω . The lower resistor values minimize noise pickup in the sensitive feedback pin. (For the lowest temperature coefficient and the best stability with time, use 1% metal film resistors.)

$$R_2=R_1(V_{OUT}/V_{REF}-1)$$

2. Inductor Selection (L1)

A. Calculate the inductor Volt • microsecond constant $E \cdot T$ ($V \cdot \mu s$), from the following formula:

$$E \cdot T=(V_{IN}-V_{OUT}-V_{SAT}) \cdot \frac{V_{OUT}+V_D}{V_{IN}-V_{SAT}+V_D} \cdot \frac{1000}{150kHz} \quad (V \cdot \mu s)$$

where V_{SAT} =internal switch saturation voltage=1.16V and V_D =diode forward voltage drop=0.5V

B. Use the $E \cdot T$ value from the previous formula and match it with the $E \cdot T$ number on the vertical axis of the Inductor Value Selection Guide shown in Figure 7.

C. on the horizontal axis, select the maximum load current.

D. Identify the inductance region intersected by the $E \cdot T$ value and the Maximum Load Current value. Each region is identified by an inductance value and an inductor code (LXX).

E. Select an appropriate inductor from the four manufacturer's part numbers listed in Figure 8.

**EXAMPLE (Adjustable Output Voltage Version)****Given:**

$$V_{OUT} = 20V$$

$$V_{IN(max)} = 28V$$

$$I_{LOAD(max)} = 2A$$

F = Switching Frequency (Fixed at a nominal 150 kHz).

1. Programming Output Voltage (Selecting R_1 and R_2 , as shown in Figure 1)

Select R_1 to be 1 k Ω , 1%. Solve for R_2 .

$$R_2 = R_1 (V_{OUT}/V_{REF} - 1) = 1k(20V/1.23V - 1)$$

$$R_2 = 1k(16.26 - 1) = 15.26k, \text{ closest 1\% value is } 15.4 \text{ k}\Omega. R_2 = 15.4 \text{ k}\Omega.$$

2. Inductor Selection (L1)

A. Calculate the inductor Volt • microsecond constant (E • T)

$$E \cdot T = (28 - 20 - 1.16) \cdot \frac{20 + 0.5}{28 - 1.16 + 0.5} \cdot \frac{1000}{150} \text{ (V} \cdot \mu\text{S)}$$

$$E \cdot T = (6.84) \cdot \frac{20.5}{27.34} \cdot 6.67 \text{ (V} \cdot \mu\text{S)} = 34.2 \text{ (V} \cdot \mu\text{S)}$$

B. $E \cdot T = 34.2 \text{ (V} \cdot \mu\text{s)}$

C. $I_{LOAD(max)} = 3A$

D. From the inductor value selection guide shown in Figure 7, the inductance region intersected by the 34 (V • μ s) horizontal L39.

E. From the table in Figure 8, locate line L39, and select an bers.



17. Block Diagram

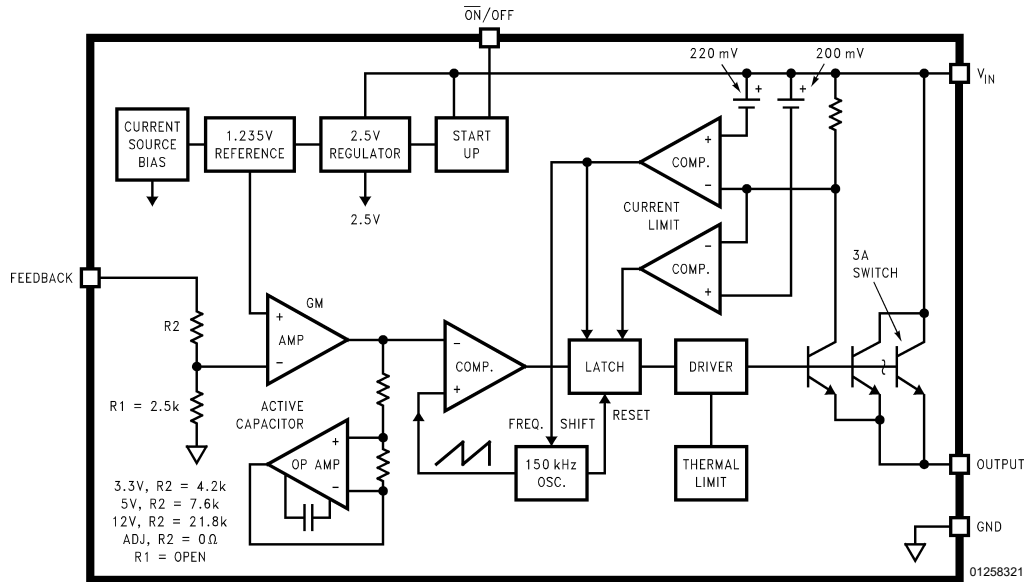

Figure 12.

18. Application Information

Pin Functions

+V_{IN} – This is the positive input supply for the IC switching regulator. A suitable input bypass capacitor must be present at this pin to minimize voltage transients and to supply the switching currents needed by the regulator.

Ground – Circuit ground.

Output – Internal switch. The voltage at this pin switches between (+V_{IN} – V_{SAT}) and approximately –0.5V, with a duty cycle of approximately V_{OUT}/V_{IN}. To minimize coupling to sensitive circuitry, the PC board copper area connected to this pin should be kept to a minimum.

Feedback – Senses the regulated output voltage to complete the feedback loop.

ON/OFF – Allows the switching regulator circuit to be shut down using logic level signals thus dropping the total input supply current to approximately 80 μA. Pulling this pin below a threshold voltage of approximately 1.3V turns the regulator on, and pulling this pin above 1.3V (up to a maximum of 25V) shuts the regulator down. If this shutdown feature is not needed, the ON/OFF pin can be wired to the ground pin or it can be left open, in either case the regulator will be in the ON condition.



External Components

Input Capacitor

C_{IN} – A low ESR aluminum or tantalum bypass capacitor is needed between the input pin and ground pin. It must be located near the regulator using short leads. This capacitor prevents large voltage transients from appearing at the input, and provides the instantaneous current needed each time the switch turns on.

The important parameters for the Input capacitor are the voltage rating and the RMS current rating. Because of the relatively high RMS currents flowing in a buck regulator's input capacitor, this capacitor should be chosen for its RMS current rating rather than its capacitance or voltage ratings, although the capacitance value and voltage rating are directly related to the RMS current rating.

The RMS current rating of a capacitor could be viewed as a capacitor's power rating. The RMS current flowing through the capacitor's internal ESR produces power which causes the internal temperature of the capacitor to rise. The RMS current rating of a capacitor is determined by the amount of current required to raise the internal temperature approximately 10°C above an ambient temperature of 105°C. The ability of the capacitor to dissipate this heat to the surrounding air will determine the amount of current the capacitor can safely sustain. Capacitors that are physically large and have a large surface area will typically have higher RMS current ratings. For a given capacitor value, a higher voltage electrolytic capacitor will be physically larger than a lower voltage capacitor, and thus be able to dissipate more heat to the surrounding air, and therefore will have a higher RMS current rating.

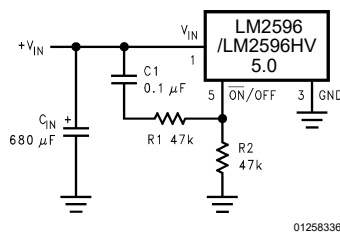

FIGURE 21. Delayed Startup

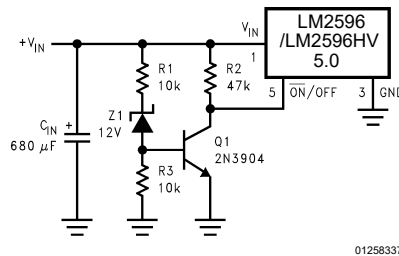
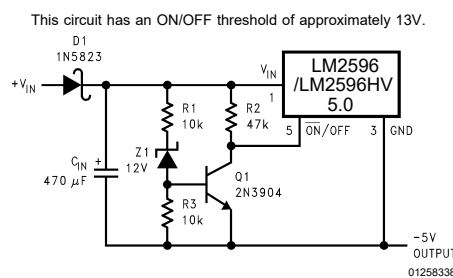

FIGURE 22. Undervoltage Lockout for Buck Regulator



for Inverting Regulator
FIGURE 23. Undervoltage Lockout



Delayed Startup

The circuit in Figure 21 uses the the $\overline{\text{ON}}/\text{OFF}$ pin to provide a time delay between the time the input voltage is applied and the time the output voltage comes up (only the circuitry pertaining to the delayed start up is shown). As the input voltage rises, the charging of capacitor C1 pulls the $\overline{\text{ON}}/\text{OFF}$ pin high, keeping the regulator off. Once the input voltage reaches its final value and the capacitor stops charging, and resistor R₂ pulls the $\overline{\text{ON}}/\text{OFF}$ pin low, thus allowing the circuit to start switching. Resistor R₁ is included to limit the maximum voltage applied to the $\overline{\text{ON}}/\text{OFF}$ pin (maximum of 25V), reduces power supply noise sensitivity, and also limits the capacitor, C1, discharge current. When high input ripple voltage exists, avoid long delay time, because this ripple can be coupled into the $\overline{\text{ON}}/\text{OFF}$ pin and cause problems. This delayed startup feature is useful in situations where the input power source is limited in the amount of current it can deliver. It allows the input voltage to rise to a higher voltage before the regulator starts operating. Buck regulators require less input current at higher input voltages.

Undervoltage Lockout

Some applications require the regulator to remain off until the input voltage reaches a predetermined voltage. An undervoltage lockout feature applied to a buck regulator is shown in Figure 22, while Figure 23 and 24 applies the same feature to an inverting circuit. The circuit in Figure 23 features a constant threshold voltage for turn on and turn off (zener voltage plus approximately one volt). If hysteresis is needed, the circuit in Figure 24 has a turn ON voltage which is different than the turn OFF voltage. The amount of hysteresis is approximately equal to the value of the output voltage. If zener voltages greater than 25V are used, an additional 47 kΩ resistor is needed from the $\overline{\text{ON}}/\text{OFF}$ pin to the ground pin to stay within the 25V maximum limit of the $\overline{\text{ON}}/\text{OFF}$ pin.

Inverting Regulator

The circuit in Figure 25 converts a positive input voltage to a negative output voltage with a common ground. The circuit operates by bootstrapping the regulator's ground pin to the negative output voltage, then grounding the feedback pin. This example uses the LM2596/LM2596HV-5.0 to generate a -5V output, but other output voltages are possible by selecting other output voltage versions, including the adjustable version. Since this regulator topology can produce an output voltage that is either greater than or less than the input voltage, the maximum output current greatly depends on both the input and output voltage. The curve shown in Figure 26 provides a guide as to the amount of output load current possible for the different input and output voltage conditions.

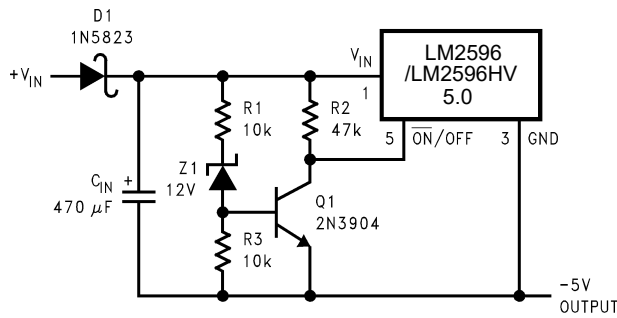

This circuit has hysteresis Regulator starts switching at $V_{IN} = 13V$ Regulator stops switching at $V_{IN} = 8V$

Figure 24. Undervoltage Lockout with Hysteresis for Inverting Regulator

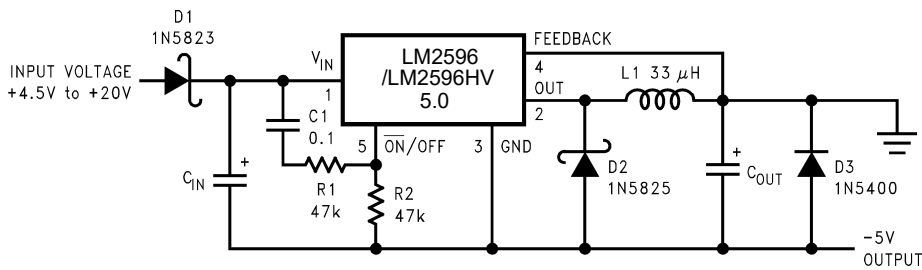

C_{IN} — 68 μ F/25V Tant. Sprague 595D

470 μ F/50V Elec. Panasonic HFQ

C_{OUT} — 47 μ F/20V Tant. Sprague 595D

220 μ F/25V Elec. Panasonic HFQ

Figure 25. Inverting -5V Regulator with Delayed Startup

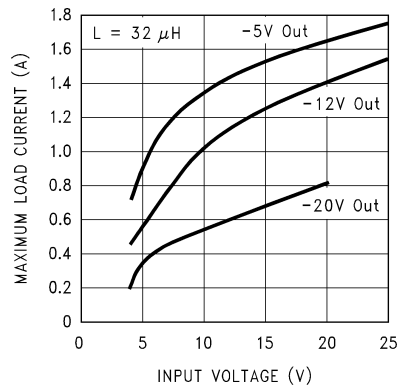

Figure 26. Inverting Regulator Typical Load Current



Because of differences in the operation of the inverting regulator, the standard design procedure is not used to select the inductor value. In the majority of designs, a 33 μH , 3.5A inductor is the best choice. Capacitor selection can also be narrowed down to just a few values. Using the values shown in Figure 25 will provide good results in the majority of inverting designs.

This type of inverting regulator can require relatively large amounts of input current when starting up, even with light loads. Input currents as high as the LM2596 /LM2596HV current limit (approx 4.5A) are needed for at least 2 ms or more, until the output reaches its nominal output voltage. The actual time depends on the output voltage and the size of the output capacitor. Input power sources that are current limited or sources that can not deliver these currents without getting loaded down, may not work correctly. Because of the relatively high startup currents required by the inverting topology the delayed startup feature (C_1 , R_1 and R_2) shown in Figure 25 is recommended. By delaying the regulator startup, the input capacitor is allowed to charge up to a higher voltage before the switcher begins operating. A portion of the high input current needed for startup is now supplied by the input capacitor (C_{IN}). For severe start up conditions, the input capacitor can be made much larger than normal.

Inverting Regulator Shutdown Methods

To use the $\overline{\text{ON}}$ /OFF pin in a standard buck configuration is simple, pull it below 1.3V(@25°C, referenced to ground) to turn regulator ON, pull it above 1.3V to shut the regulator OFF. With the inverting configuration, some level shifting is required, because the ground pin of the regulator is no longer at ground, but is now setting at the negative output voltage level. Two different shutdown methods for inverting regulators are shown in Figure 27 and 28.

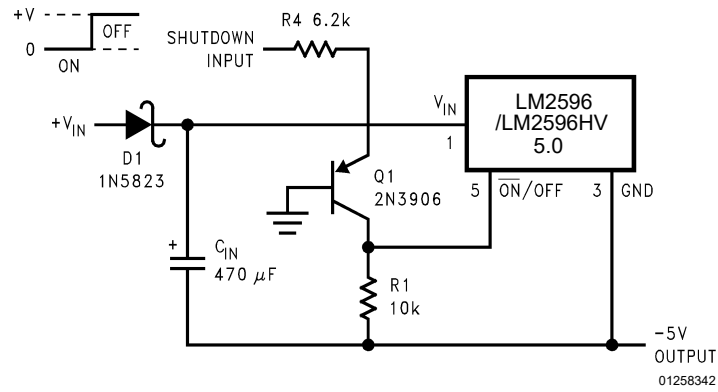

Figure 27. Inverting Regulator Ground Referenced Shutdown

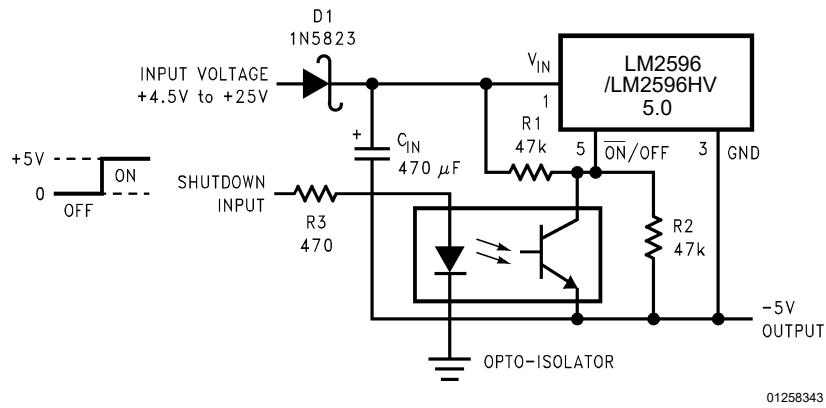
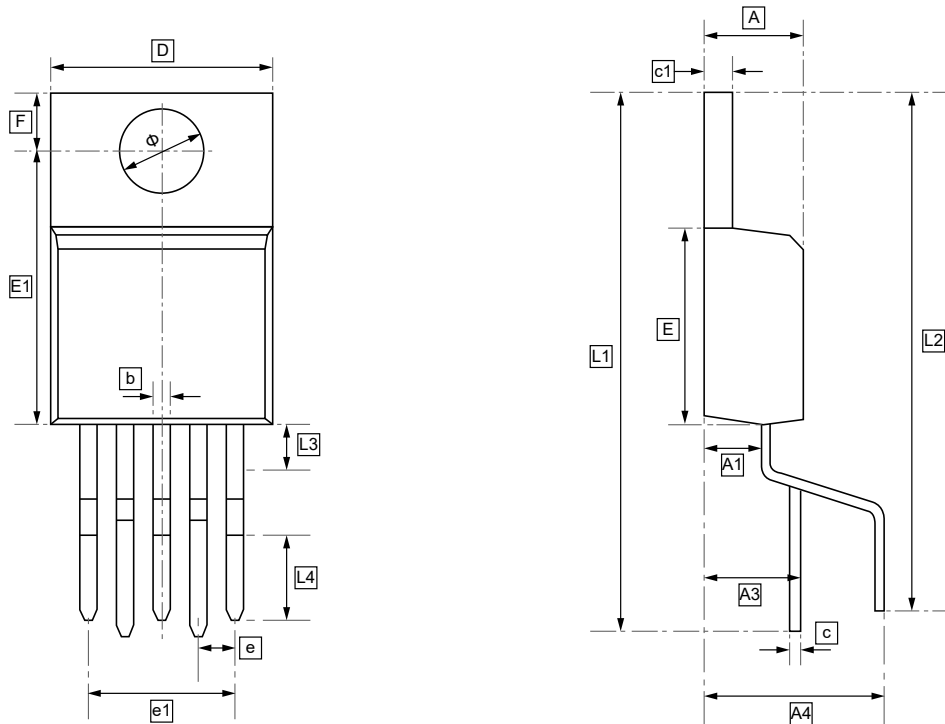

Figure 28. Inverting Regulator Ground Referenced Shutdown using Opto Device



19.1 TO220B-5L Package Outline Dimensions



DIMENSIONS (mm are the original dimensions)

Symbol	A	A1	A3	A4	b	c	c1	D	E	E1	e	e1
Min	4.470	2.520	4.450	8.350	0.710	0.310	1.170	10.010	8.900	12.460	1.700	6.700
Max	4.670	2.820	4.850	8.750	0.910	0.530	1.370	10.310	9.300	12.860	TYP	6.900

Symbol	F	L1	L2	L3	L4	R	Φ
Min	2.590	26.800	24.800	1.000	6.000	0.950	3.790
Max	2.890	27.400	25.200	2.000	6.400	1.050	3.890



19.2 TO220-5L Package Outline Dimensions

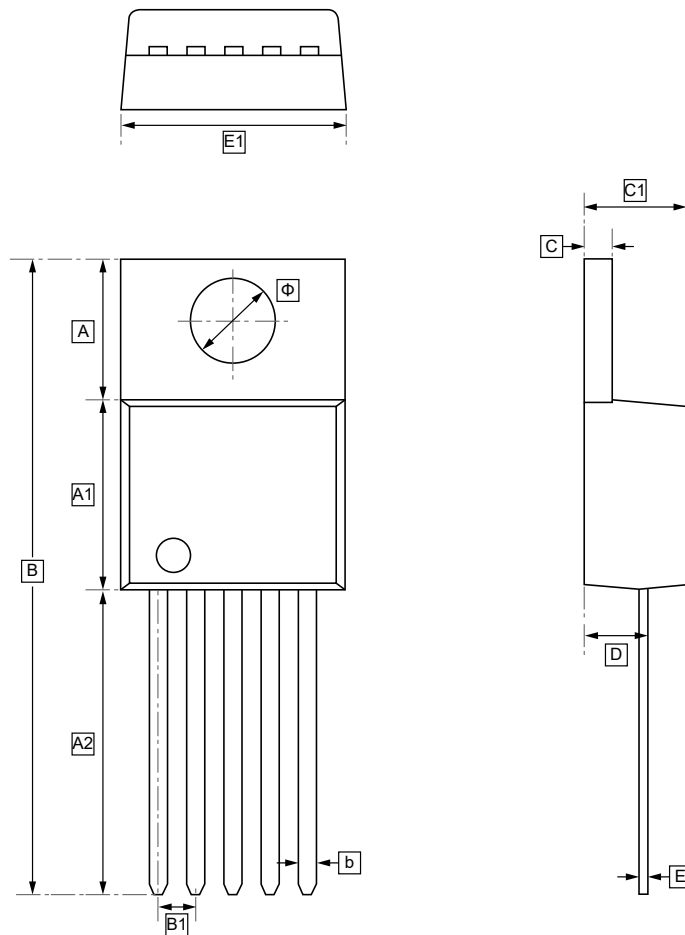

DIMENSIONS (mm are the original dimensions)

Symbol	A	A1	A2	B	B1	b	C	C1	D	E	E1	Φ
Min	6.3	8.48	13.67	28.55	1.70	0.75	1.20	0.45	2.38	0.33	10.00	3.80
Max	6.4	8.68	13.97	28.95		0.85	1.30	0.65	2.58	0.43	10.20	3.90



19.3 TO-263 Package Outline Dimensions

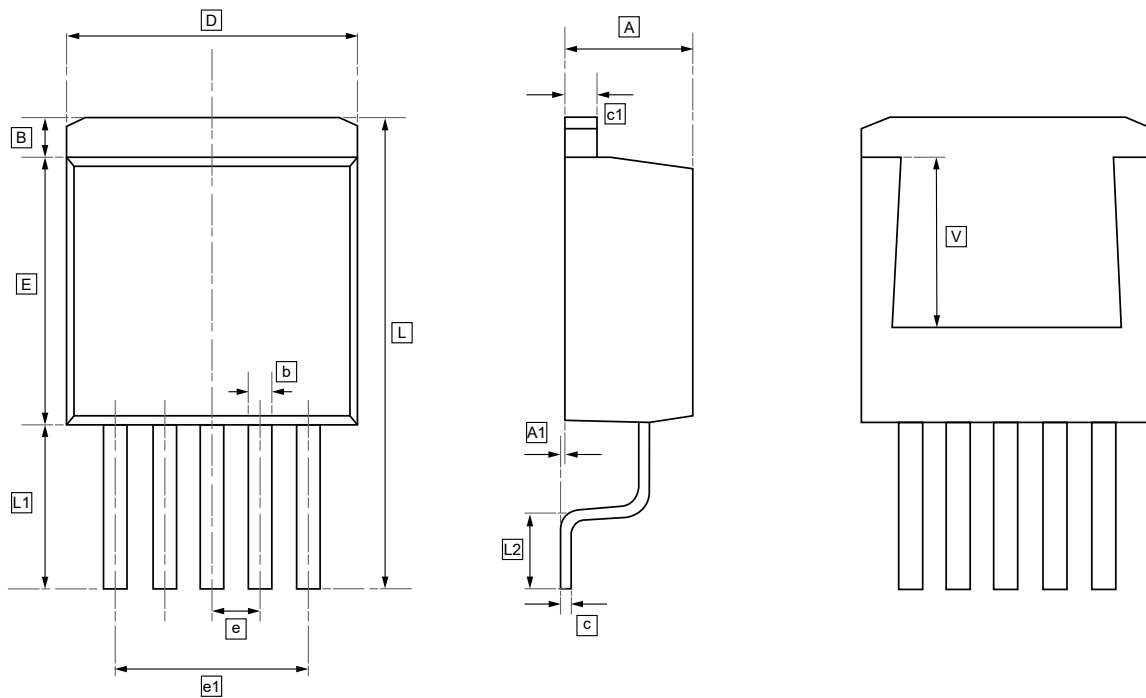

DIMENSIONS (mm are the original dimensions)

Symbol	A	A1	B	b	c	c1	D	E	e	e1	L	L1
Min	4.470	0.000	1.560	0.710	0.310	1.170	9.880	8.200	1.700	6.700	15.140	5.080
Max	4.670	0.150	1.760	0.910	0.530	1.370	10.180	8.600	TYP	6.900	15.540	5.480

Symbol	L2	V
Min	2.340	5.600
Max	2.740	REF



20. Ordering Information

UMW yyww
LM2596S
-ADJ P+

○

yy: Year Code
ww: Week Code

Order Code	Marking	Package	Base QTY	Delivery Mode
UMW LM2596HVS-12	LM2596HVS	TO-263	800	Tape and reel
UMW LM2596HVS-3.3	LM2596HVS	TO-263	800	Tape and reel
UMW LM2596HVS-5.0	LM2596HVS	TO-263	800	Tape and reel
UMW LM2596HVS-ADJ	LM2596HVS	TO-263	800	Tape and reel
UMW LM2596S-12	LM2596S	TO-263	800	Tape and reel
UMW LM2596S-3.3	LM2596S	TO-263	800	Tape and reel
UMW LM2596S-5.0	LM2596S	TO-263	800	Tape and reel
UMW LM2596S-ADJ	LM2596S	TO-263	800	Tape and reel



21.Disclaimer

UMW reserves the right to make changes to all products, specifications. Customers should obtain the latest version of product documentation and verify the completeness and currency of the information before placing an order.

When applying our products, please do not exceed the maximum rated values, as this may affect the reliability of the entire system. Under certain conditions, any semiconductor product may experience faults or failures. Buyers are responsible for adhering to safety standards and implementing safety measures during system design, prototyping, and manufacturing when using our products to prevent potential failure risks that could lead to personal injury or property damage.

Unless explicitly stated in writing, UMW products are not intended for use in medical, life-saving, or life-sustaining applications, nor for any other applications where product failure could result in personal injury or death. If customers use or sell the product for such applications without explicit authorization, they assume all associated risks.

When reselling, applying, or exporting, please comply with export control laws and regulations of China, the United States, the United Kingdom, the European Union, and other relevant countries, regions, and international organizations.

This document and any actions by UMW do not grant any intellectual property rights, whether express or implied, by estoppel or otherwise. The product names and marks mentioned herein may be trademarks of their respective owners.