



EVERLIGHT ELECTRONICS CO.,LTD.

DATA SHEET

PART NO. : 15-21/GHC-R1S1/2T

DATE :

DEPARTMENT : R.D.1

REVISION : 1.0

RECEIVED			
<input checked="" type="checkbox"/> MASS PRODUCTION			
<input type="checkbox"/> PRELIMINARY			
<input type="checkbox"/> CUSTOMER DESIGN			
DEVICE NUMBER : DSE-151-G01			
PAGE : 12			
CUSTOMER	DESIGNER	CHECKER	APPROVER
	JEFF TSAI	CHARLES CHANG	

REV	DESCRIPTION	RELEASE DATE

OFFICE : NO 25,Lane 76,Chung Yang Rd,Sec.3 Tucheng, Taipei 236, Taiwan, R.O.C.

TEL : 886-2-2267-2000,2266-9936 (22 Lines)

FAX : 886-2-2267-6189

<http://www.everlight.com>



Package Type:

SMD For PCB Type

11-21	19-215
12-21	19-215A
12-215	19-217A
15-21	22-21
15-215	23-21
16-213	23-21B
17-21	24-21
17-215	25-21
19-21	27-21
19-21A	42-21

Dominant Wavelength Groups:

According to the difference wavelength to define
 None: No definition
 A : Standard wavelength definition.
 B : Range of wavelength definition is more narrowly than group A.
 C : Range of wavelength definition is more narrowly than group A, but the value is different with group B.
 F : The wavelength definition in special specification.

The dominant wavelength data did not including ±1nm testing tolerance.

Test Forward Current:

None: 20 mA
 Y : 5 mA
 Z : 10 mA

Taping Quantity:

- 1: 1000 pcs (Taping)
- 2: 2000 pcs (Taping)
- 3: 3000 pcs (Taping)
- 5: 5000 pcs (Taping)
- C : 1500 pcs (Taping)
- D : 10000 pcs (Taping)

Packing Method :

- A: Reverse-side placement (Anode toward the sprocket hole)
- B: Reverse-side placement (Anode toward the sprocket hole)
- C: Right-side placement
- D: Right-side placement (Anode toward the sprocket hole)
- T: Top-side placement
- R: Top-side placement (Anode toward the sprocket hole)

19 - 21 / B H C - A N1 P2 M / 3 T

Emission Color:

- R: Red (λ d: 640nm, 630nm, 625nm)
- S: Sunset Orange (λ d: 615nm, 605nm)
- Y: Yellow (λ d: 595nm, 590nm)
- G: Green (λ d: 570nm, 565nm, 560nm, 525nm, 505nm)
- B: Blue (λ d: 470nm)
- W: White x=0.32 y=0.31

The ordinal number that base on diffece electro-optical characteristics within chip.

1,2 7,8,9, A,B.....X,Y,Z

Resin Color:

- C: Water Clear
- W: White Diffused
- D: Diffused

Luminous Intensity Groups:

- | | | |
|-------------------|-----|-------------------|
| C0: 0.28 ... 0.45 | R ⇨ | R1: 112 ... 140 |
| D0: 0.45 ... 0.70 | S ⇨ | R2: 140 ... 180 |
| E0: 0.70 ... 1.1 | T ⇨ | S1: 180 ... 225 |
| F0: 1.1 ... 1.8 | U ⇨ | S2: 225 ... 285 |
| G0: 1.8 ... 2.8 | V ⇨ | T1: 285 ... 360 |
| H0: 2.8 ... 4.5 | W ⇨ | T2: 360 ... 450 |
| J0: 4.5 ... 7.2 | X ⇨ | U1: 450 ... 565 |
| K0: 7.2 ... 11.5 | Y ⇨ | U2: 565 ... 715 |
| L1: 11.5 ... 14.5 | | V1: 715 ... 900 |
| L2: 14.5 ... 18.0 | | V2: 900 ... 1120 |
| M1: 18.0 ... 22.5 | | W1: 1120 ... 1420 |
| M2: 22.5 ... 28.5 | | W2: 1420 ... 1800 |
| N1: 28.5 ... 36.0 | | X1: 1800 ... 2250 |
| N2: 36.0 ... 45.0 | | X2: 2250 ... 2850 |
| P1: 45.0 ... 57.0 | | Y1: 2850 ... 3600 |
| P2: 57.0 ... 72.0 | | Y2: 3600 ... 4500 |
| Q1: 72.0 ... 90.0 | | |
| Q2: 90.0 ... 112 | | |

Unit: mcd

The luminous intensity data did not including ±15% testing tolerance.

Forward Voltage Groups:

None: No definition

The VF definition as follows:

		Unit: V			
Forward Voltage Group	Bin	Min.	Max.		
C	0	1.55	1.75		
	1	1.75	1.95		
	2	2.15	2.35		
	3	2.35	2.55		
	4	2.55	2.75		
M	5	2.75	3.05		
	6	3.05	3.35		
	7	3.35	3.65		
	8	3.65	3.95		
N	9	2.50	2.70		
	10	2.70	2.90		
	11	2.90	3.10		
	12	3.10	3.30		
	13	3.30	3.50		
	14	3.50	3.70		
	P	15	2.70	2.85	
		16	2.85	3.00	
		17	3.00	3.15	
		18	3.15	3.30	

The forward voltage data did not including ±0.1V testing tolerance.

第二代SMD---PQC&FQA分色規格(PQC&FQA λ d SPEC.) :

Chip	G2			
Dom . Wavelength	Range			
Of Group	Bin	Min.	Max.	Unit
A	C9	555	558	nm
	C10	557	560	nm
	C11	559	562	nm
	C12	561	564	nm
λ p of SPEC.:549~561nm				

Chip	G3				
Dom . Wavelength	Range				
Of Group	Bin	Min.	Max.	Unit	
A	B	C11	559	562	nm
		C12	561	564	nm
		C13	563	566	nm
		C14	565	568	nm
		C15	567	570	nm
λ p of SPEC.:554~566nm					

Chip	G5				
Dom . Wavelength	Range				
Of Group	Bin	Min.	Max.	Unit	
A	B	C15	567	570	nm
		C16	569	572	nm
		C17	571	574	nm
		C18	573	576	nm
F	CC1	569.5	571.0	nm	
	CC2	570.0	572.5	nm	
	CC3	571.5	574.0	nm	
λ p of SPEC.:564~576nm					

Chip	G6				
Dom . Wavelength	Range				
Of Group	Bin	Min.	Max.	Unit	
A	B	C16	569	572	nm
		C17	571	574	nm
		C18	573	576	nm
		C19	575	578	nm
F	CC2	569.0	572.5	nm	
	CC3	571.5	574.0	nm	
	CC4	572.0	575.5	nm	
λ p of SPEC.:569~581nm					



Technical Data Sheet

1206 Package Chip LED

15-21/G__C Series *1

Features

- Package in 8mm tape on 7" diameter reel.
- Compatible with automatic placement equipment.
- Compatible with infrared and vapor phase reflow solder process.
- Mono-color type.



Descriptions

- The 15-21 SMD Taping is much smaller than lead frame type components, thus enable smaller board size, higher packing density, reduced storage space and finally smaller equipment to be obtained.
- Besides, lightweight makes them ideal for miniature applications. etc.

Applications

- Automotive: backlighting in dashboard and switch.
- Telecommunication: indicator and backlighting in telephone and fax.
- Flat backlight for LCD, switch and symbol.
- General use.

Device Selection Guide

Part No.	Chip		Lens Color
	Material	Emitted Color	
15-21/G2C	GaP	Pure Green	Water Clear
15-21/G3C		Pale Green	
15-21/G5C		Yellow Green	
15-21/G6C	AlGaInP	Brilliant Yellow Green	
15-21/GLC	InGaN	Bluish Green	
15-21/GHC	InGaN	Brilliant Green	
15-21/GPC *2	AlGaInP	Pale Green	

*1. The series is included 15-21/G2C,15-21/G3C,15-21/G5C, 15-21/G6C,15-21/GLC,15-21/GHC,and 15-21/GPC.

*2. Preliminary product.

Package Outline Dimensions

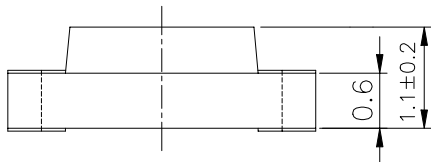
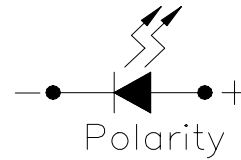
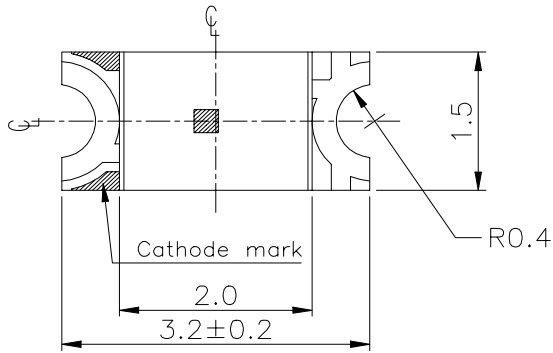

For reflow soldering (propose)

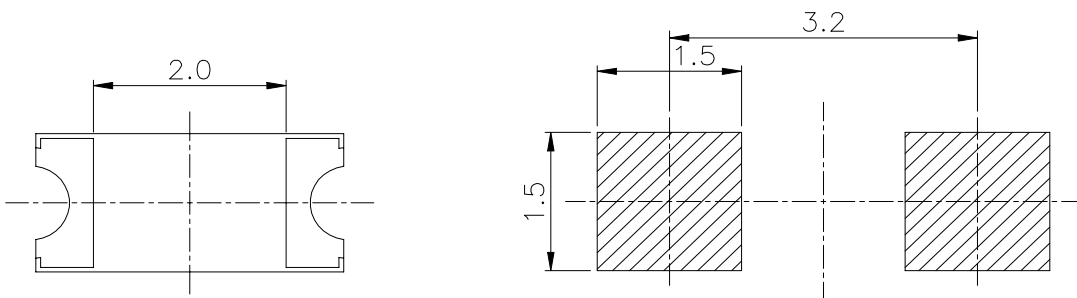

Notes: Tolerances Unless Dimension $\pm 0.1\text{mm}$, Angle $\pm 0.5^\circ$,Unit = mm

15-21/G_C Series
Absolute Maximum Ratings (Ta=25°C)

Series	Parameter	Symbol	Rating	Unit
15-21/G_C Series	Reverse Voltage	V _R	5	V
15-21/G_C Series	Forward Current	I _F	30	mA
15-21/ G6C/GLC/GHC/GPC			25	
15-21/G_C Series	Operating Temperature	T _{opr}	-40 ~ +85	°C
15-21/G_C Series	Storage Temperature	T _{stg}	-40 ~ +90	°C
15-21/G_C Series	Soldering Temperature	T _{sol}	260 (for 5 seconds)	°C
15-21/G_C Series	Electrostatic Discharge	ESD	2000	V
15-21/GLC/GHC			150	
15-21/G_C Series	Power Dissipation	P _d	130	mW
15-21/ G2C/G3C/G5C			100	
15-21/G6C/GPC			60	
15-21/G_C Series	Peak Forward Current (Duty 1/10 @1KHz)	I _F	160	mA
15-21/GLC/GHC			100	

15-21/G__C Series
Electro-Optical Characteristics (Ta=25°C)

Part No.	Parameter	Symbol	Min.	Typ.	Max.	Unit	Condition
15-21/G2C	Peak Wavelength	λ_p	----	555	----	nm	IF=20mA
15-21/G3C				560			
15-21/G5C				570			
15-21/G6C				575			
15-21/GLC				502			
15-21/GHC				518			
15-21/GPC				561			
15-21/G2C				Dominant Wavelength			
15-21/G3C	565						
15-21/G5C	571						
15-21/G6C	573						
15-21/GLC	505						
15-21/GHC	525						
15-21/GPC	562						

Electro-Optical Characteristics (Ta=25°C)

Part No.	Parameter	Symbol	Min.	Typ.	Max.	Unit	Condition
15-21/G2C	Spectrum Radiation Bandwidth	$\Delta \lambda$	----	30	----	nm	IF=20mA
15-21/G3C				30			
15-21/G5C				30			
15-21/G6C				20			
15-21/GLC				30			
15-21/GHC				36			
15-21/GPC				20			
15-21/G_C Series	Viewing Angle	$2\theta 1/2$	----	130	----	deg	
15-21/G_C Series	Forward Voltage	VF	----	2.0	2.4	V	
15-21/GLC/GHC				3.5	4.3		
15-21/G_C Series	Reverse Current	IR	----	----	10	μA	VR=5V
15-21/ GLC/GHC/GPC					50		

15-21/G__C Series
■15-21/G__C Series Explain Of Luminous Intensity:
IF=20mA

Part No.	Parameter	Symbol	Typ.	Bin Code	Min.	Max.	Unit
15-21/G2C-G0J0	Luminous Intensity	Iv	2.7	G0	1.8	2.8	mcd
				H0	2.8	4.5	
				J0	4.5	7.2	
15-21/G3C-J0L1	Luminous Intensity	Iv	7.0	J0	4.5	7.2	mcd
				K0	7.2	11.5	
				L1	11.5	14.5	
15-21/G5C-K0L2	Luminous Intensity	Iv	11	K0	7.2	11.5	mcd
				L1	11.5	14.5	
				L2	14.5	18.0	
15-21/G5C-L1M1	Luminous Intensity	Iv	16	L1	11.5	14.5	mcd
				L2	14.5	18.0	
				M1	18.0	22.5	

Note:

The luminous intensity data did not including $\pm 15\%$ testing tolerance.

15-21/G__C Series
15-21/G__C Series Explain Of Luminous Intensity:
I_F=20mA

Part No.	Parameter	Symbol	Typ.	Bin Code	Min.	Max.	Unit
15-21/G6C-L2M2	Luminous Intensity	I _v	21	L2	14.5	18.0	mcd
				M1	18.0	22.5	
				M2	22.5	28.5	
15-21/G6C-M2N2	Luminous Intensity	I _v	32	M2	22.5	28.5	mcd
				N1	28.5	36.0	
				N2	36.0	45.0	
15-21/G6C-N1P1	Luminous Intensity	I _v	42	N1	28.5	36.0	mcd
				N2	36.0	45.0	
				P1	45.0	57.0	
15-21/GLC-Q1R1	Luminous Intensity	I _v	110	Q1	72.0	90.0	mcd
				Q2	90.0	112	
				R1	112	140	
15-21/GHC-R1S1	Luminous Intensity	I _v	160	R1	112	140	mcd
				R2	140	180	
				S1	180	225	
15-21/GPC-K0L2	Luminous Intensity	I _v	12	K0	7.2	11.5	mcd
				L1	11.5	14.5	
				L2	14.5	18.0	

Note:

 The luminous intensity data did not including $\pm 15\%$ testing tolerance.

Typical Electro-Optical Characteristics Curves

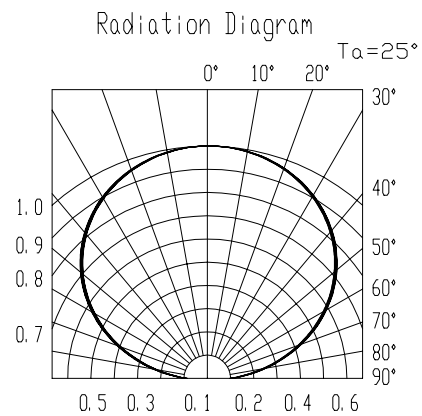
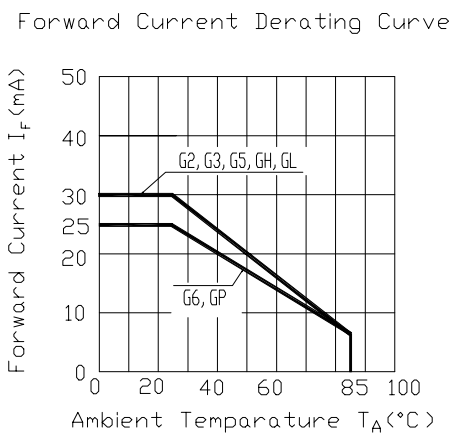
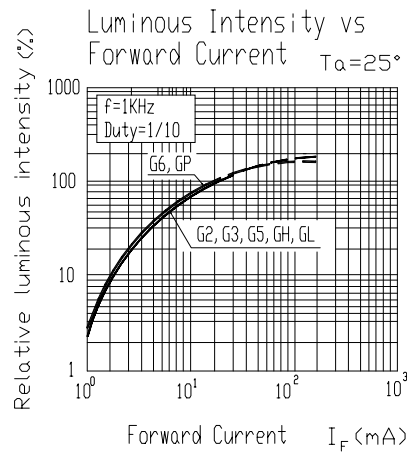
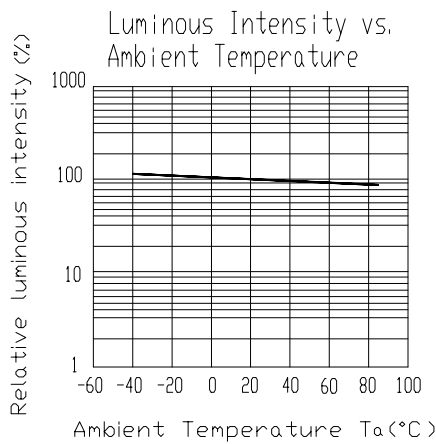
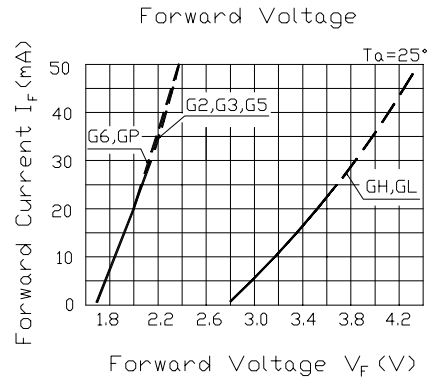
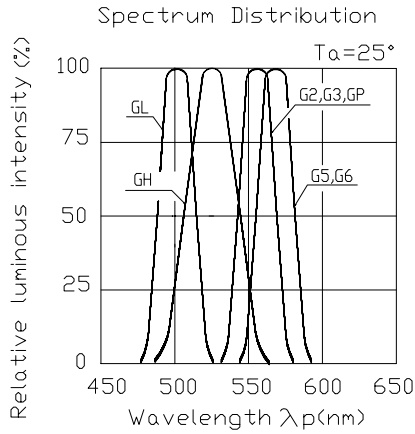

15-21/G__C Series

Reel & Carrier Tape Dimensions

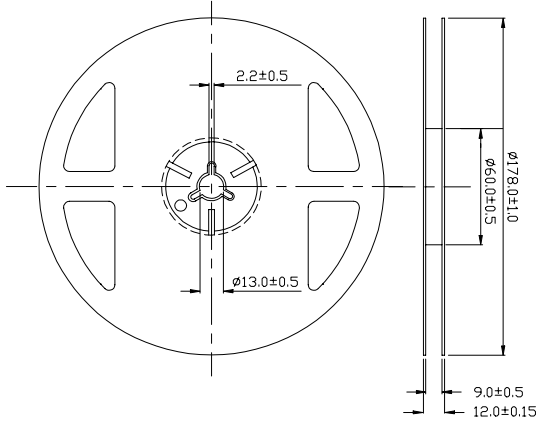

Loaded quantity per reel 2000 PCS/reel

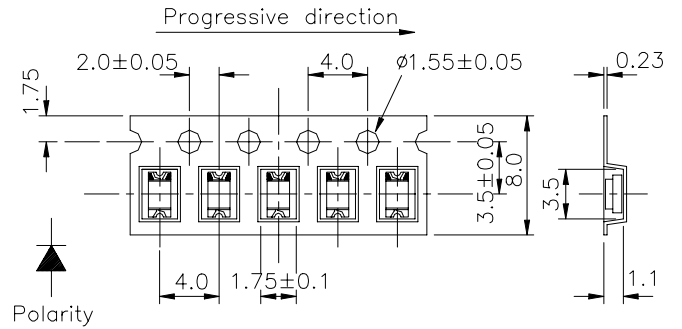

Notes: Tolerances Unless Dimension $\pm 0.1\text{mm}$, Angle $\pm 0.5^\circ$,Unit = mm

Label explanation

CAT: Luminous Intensity (mcd)

HUE: Dom. Wavelength (nm)

REF: Forward Voltage (V)

EVERLIGHT

CPN :
P/N: XXXXXXXXXXXX



XX-XXXXXXXX

QTY: XXXX



LOT NO: XXXXXXXXXXX



CAT:
HUE:
REF:

MADE IN TAIWAN

Iv λd VF

Reliability Test Items And Conditions

The reliability of products shall be satisfied with items listed below.

Confidence level : 90 %

LTPD : 10 %

No.	Items	Test Condition	Test Hours/Cycles	Sample Size	Ac/Rc
1	Reflow	Temp. : 240°C ± 5°C Min. 5 sec.	5 Sec.	22 Pcs.	0/1
2	Temperature Cycle	H : +85°C 30 min. § 5 min. L : -55°C 30 min.	50 Cycles	22 Pcs.	0/1
3	Thermal Shock	H : +100°C 5 min. § 10 sec. L : -10°C 5 min.	50 Cycles	22 Pcs.	0/1
4	High Temperature Storage	Temp. : 100°C	1000 Hrs.	22 Pcs.	0/1
5	Low Temperature Storage	Temp. : -55°C	1000 Hrs.	22 Pcs.	0/1
6	DC Operating Life	IF = 20 mA	1000 Hrs.	22 Pcs.	0/1
7	High Temperature / High Humidity	85°C/RH 85%	1000 Hrs.	22 Pcs.	0/1

Precautions For Use

1. Over-current-proof

Customer must apply resistors for protection , otherwise slight voltage shift will cause big current change (Burn out will happen).

2. Storage time

2.1 The operation of Temperature and RH are : 5°C ~35°C , RH60%.

2.2 Once the package is opened, the products should be used within a week.

Otherwise, they should be kept in a damp proof box with descanting agent.

Considering the tape life , we suggest our customers to use our products within a year(from production date).

2.3 If opened more than one week in an atmosphere 5°C ~35°C , RH 60%, they should be treated at 60°C± 5°C for 15hrs.

2.4 When you discover that the desiccant in the package has a pink color (Normal = blue) , you should treat them in the same conditions as 2.3.

Soldering heat

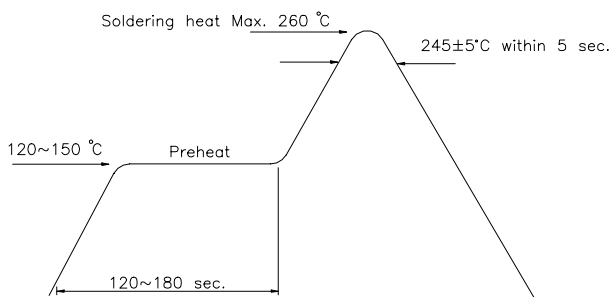

Reflow Temp / Time

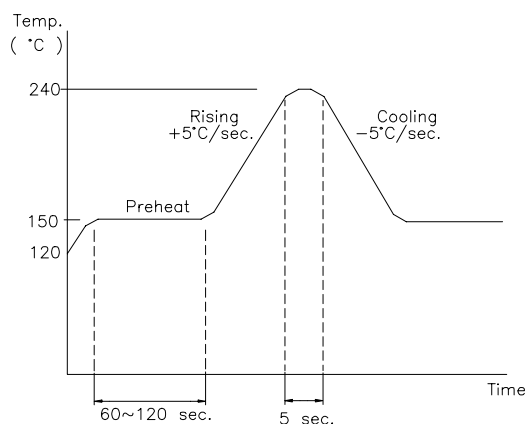

Soldering Iron

Basic spec is ≤ 5 sec when 260°C. If temperature is higher, time should be shorter (+10°C → -1sec).

Power dissipation of Iron should be smaller than 15 W , and temperature should be controllable.

Surface temperature of the device should be under 230 °C .

Rework

1. Customer must finish rework within 5 sec under 245°C.
2. The head of iron can not touch copper foil.
3. Twin-head type is preferred.

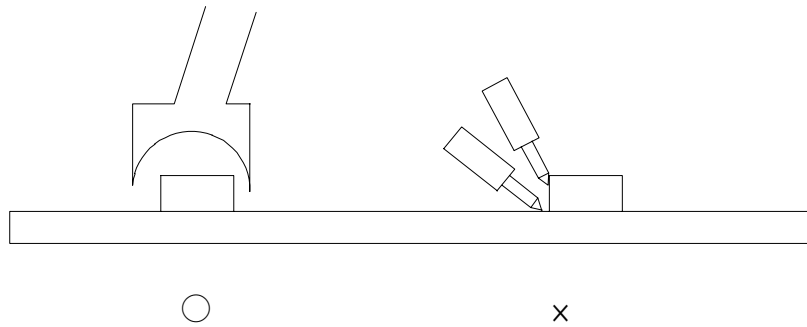

EVERLIGHT ELECTRONICS CO., LTD.
Office: No 25, Lane 76, Sec 3, Chung Yang Rd,
Tucheng, Taipei 236, Taiwan, R.O.C

Tel: 886-2-2267-2000, 2267-9936
Fax: 886-2267-6244, 2267-6189, 2267-6306
<http://www.everlight.com>