

EC11-1B-18T with switch

OUTLINE DRAWING

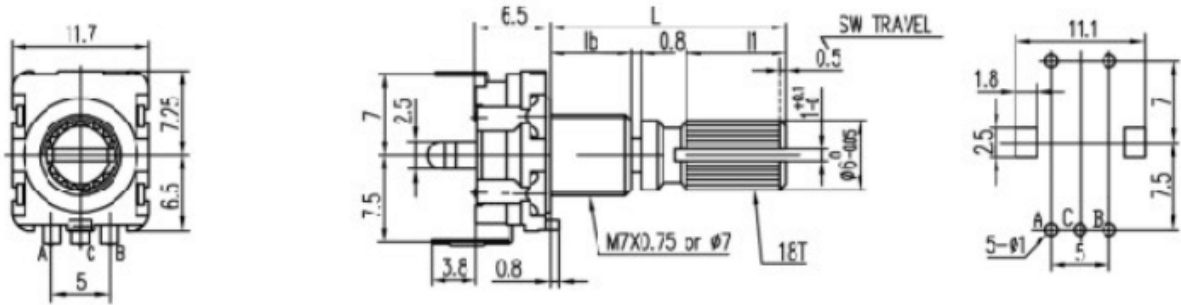

L	13	15	20	23.5	25
lb	7	5	7	7	7
ll/f	3	7	5	10	12

SPECIFICATIONS

Type 型号	EC11
Power Rating 额定功率	DC5V 5Ma
Detent torque 定位点脱出力	40-80gf.cm
Rotation life(cycles) 回转寿命	30000cycles
Insulation resistance 绝缘阻抗	DC50V/100Mohm min
Withstand voltage 耐电压	AV100V/1minute
Switch Ratings 开关额定功率	DC5V 10Ma
Switch Operating force 开关操作力	600±20gf
Switch contact resistance 开关接触电阻	≤200mohm
Travel of switch 按压开关位移量	0.5±0.3mm
Switch life 开关寿命	10,000cycles