

Tab Contacts

**Tabs 1.6 x 0.6 mm
with Steel Top Spring,
Mates with
Micro Timer II**

Extraction Tool:
Part No. **539960-1**

Product Specification:
108-18331

Application Specification:
114-18082

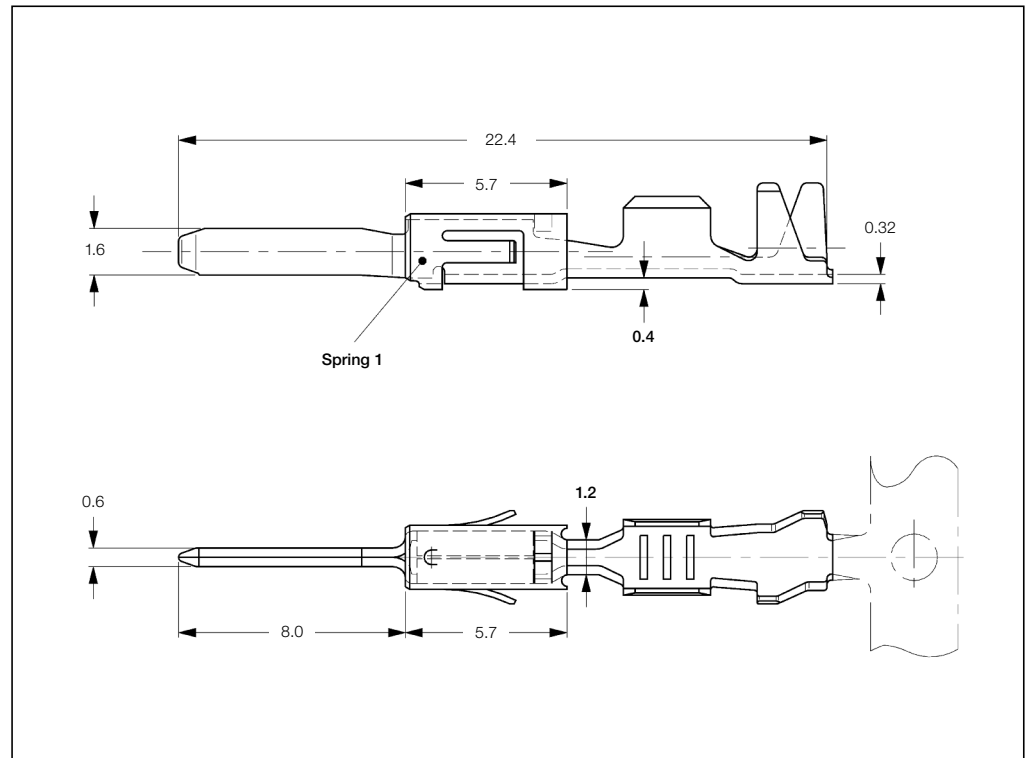

Standard Tab Contacts

Wire Size Range (mm ²)	Insulation Diameter (mm)		Material and Finish*	Part Numbers				Applicator ♦	Hand Tool
	FLK	FLR		Strip Form	Package Quantity	Loose-Piece	Package Quantity		
0.2-0.5	-	1.15-1.60	-1 / -2 / -3	963898 1)	7,000	963899 1)	500	1528061	2063265-1
0.5-1.0	-	1.4-2.1	-1 / -2 / -3 / -4	963900 1)	6,000	963901 1)	500	1528256	

Tab Contacts with Single Wire Sealing System

Wire Size Range (mm ²)	Insulation Diameter (mm)		Material and Finish*	Part Numbers				Applicator ♦	Hand Tool
	FLK	FLR		Strip Form	Package Quantity	Loose-Piece	Package Quantity		
0.2-0.5	-	1.15-1.60	-1 / -2 / -3	963902 1)	4,000	963903 1)	500	1528281	2063265-1
0.5-1.0	-	1.4-2.1	-1 / -2 / -3	963904 1)	4,000	963905 1)	500	1528054	

***) Material and Finish:**
xxx-1 = CuSn4, pre-tin plated
xxx-2 = CuFe2, pre-tin plated
xxx-3 = CuSn4, gold plated
xxx-4 = CuSn4, gold plated

Remarks:
1) = With Spring 1

♦) The pre- and suffix for the applicators depends on the applied termination equipment.

Tab Contacts

**Tabs 1.6 x 0.6 mm
with Modified
Steel Top Spring,
Mates with
Micro Timer II**

Extraction Tool:
Part No. **539960-1**

Product Group Drawing:
1355055

Product Specification:
108-18331

Application Specification:
114-18082

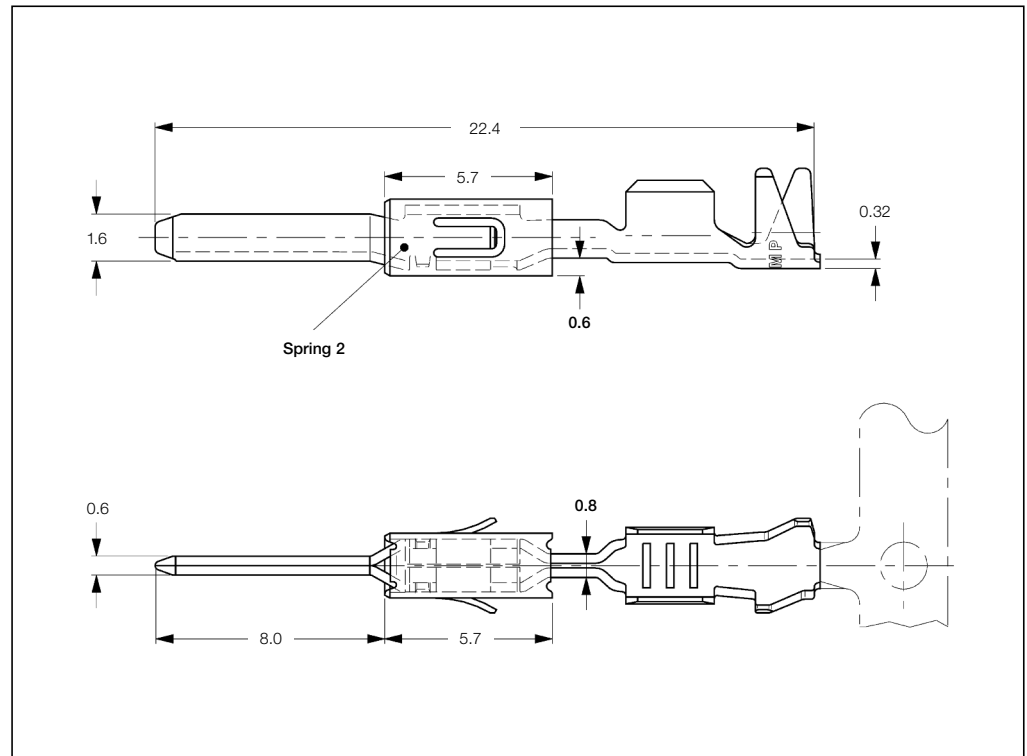

Standard Tab Contacts with Modified Spring

Wire Size Range (mm ²)	Insulation Diameter (mm)		Material and Finish*	Part Numbers				Applicator ♦	Hand Tool
	FLK	FLR		Strip Form	Package Quantity	Loose-Piece	Package Quantity		
0.2-0.5	-	1.15-1.60	-2 / -3	964265 2)	7,500	964266 2)	500	1528091	
0.5-1.0	-	1.4-2.1	-2 / -3	969079 2) 3)	5,500	969080 2) 3)	500	1528096	2063409-1
			-1 / -2 / -3	964267 2)	6,000	964268 2)	500	1528092	
1.5	-	2.2-2.4	-1 / -2 / -3	1241846 2)	4,000	1241847 2)	500	1528123	-

Tab Contacts with Modified Spring and Single Wire Sealing System

Wire Size Range (mm ²)	Insulation Diameter (mm)		Material and Finish*	Part Numbers				Applicator ♦	Hand Tool
	FLK	FLR		Strip Form	Package Quantity	Loose-Piece	Package Quantity		
0.2-0.5	-	1.2-1.6	-2 / -3	969028 2)	4,000	969029 2)	500	1528068	
0.5-1.0	-	1.4-2.1	-2 / -3	964269 2)	4,000	964270 2)	500	1528261	2063409-1
			-1	1703278	4,000	1703279	500	1528579	-

*) **Material and Finish:**
xxx-1 = CuSn4, pre-tin plated
xxx-2 = CuFe2, pre-tin plated
xxx-3 = CuSn4, gold plated

Remarks:
2) = With Spring 1 or Spring 2
3) = For Double and Single Termination

♦) The pre- and suffix for the applicators depends on the applied termination equipment.