

CERAMIC CAPACITORS

SAFETY RECOGNIZED CAPACITORS—KD TYPE

4KVAC FLASH

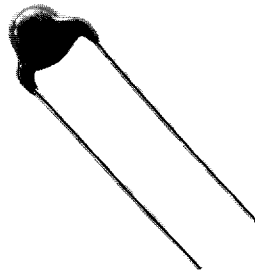

DIMENSIONS: mm

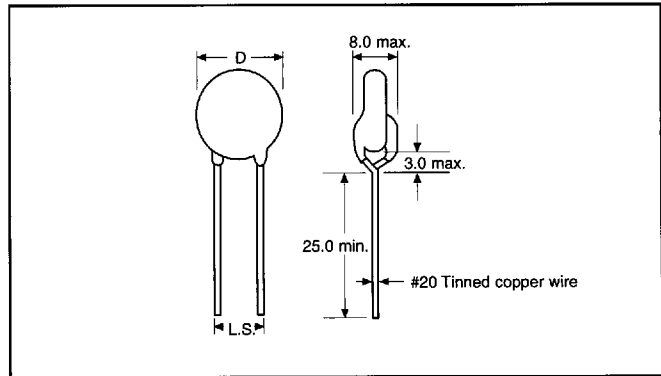

PART NUMBERING SYSTEM

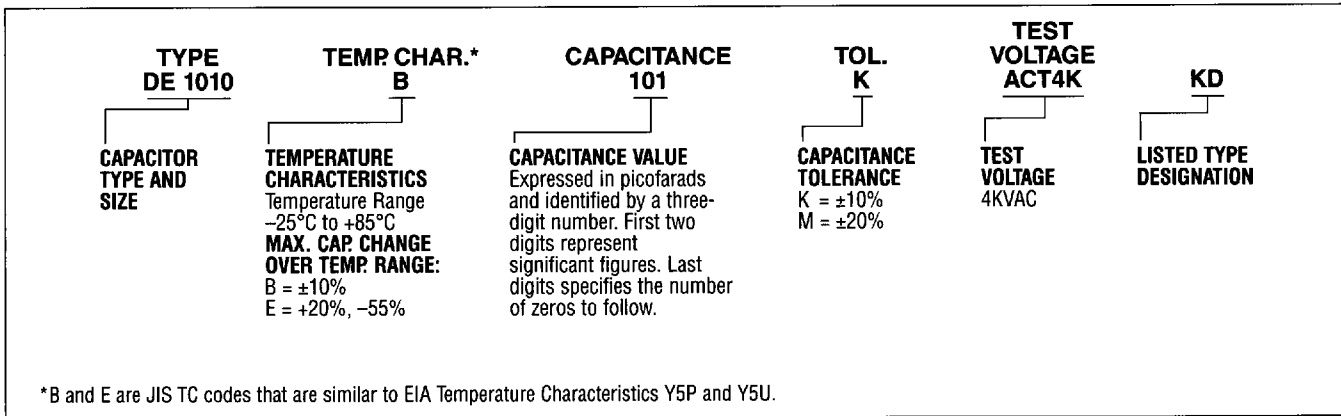

CERAMIC CAPACITORS

TYPICAL MARKING

Part Number	D max. mm	L.S.	Cap. Value (pF)
*DE1010 B 101K ACT4K-KD	10.0	10	100
*DE1010 B 151K ACT4K-KD	10.0	10	150
*DE1010 B 221K ACT4K-KD	10.0	10	220
*DE1010 B 331K ACT4K-KD	10.0	10	330
*DE1010 B 471K ACT4K-KD	10.0	10	470
*DE1010 E 681M ACT4K-KD	10.0	10	680
*DE1110 E 102M ACT4K-KD	11.0	10	1000
*DE1410 E 222M ACT4K-KD	14.0	10	2200
*DE1610 E 332M ACT4K-KD	16.0	10	3300
*DE1710 E 392M ACT4K-KD	17.0	10	3900
*DE1910 E 472M ACT4K-KD	19.0	10	4700

Item	Example
UL Recognized Mark	
VDE Approval Mark	
SEMKO Approval Mark	
IMQ Approval Mark	
CSA Monogram	
SEV Approval Mark	
FIMKO Approval Mark	
NEMKO Approval Mark	
DEMKO Approval Mark	
BSI Approval Mark	BS 415
Class Code	X 1, Y 1
Rated Voltage	250~
Type Designation	KD
Nominal Capacitance	—
Capacitance Tolerance	—
Testing Voltage	T4KV
Manufacturer's Name	Ⓜ3
Manufactured Date Code	—

Marking on one side

For DE1910E472MACT4K-KD

Note: Please refer to page 92 for Standard Recognitions by Part Number.
*Available as standard through authorized Murata Electronics Distributors.

CERAMIC CAPACITORS SAFETY RECOGNIZED CAPACITORS—KC, KH & KD TYPE STANDARDS



TYPE KC

Part Number	Recognized Standard No.				
	IEC384-14 2nd Edition (1993)	UL1414	C22.2 No. 0, No. 1	BSI EN60065	AS3250
	X1/Y2	—	—	X1/Y2	—
DE7090 B 101 K VA1-KC	○	○	○	○	○
DE7090 B 151 K VA1-KC	○	○	○	○	○
DE7090 B 221 K VA1-KC	○	○	○	○	○
DE7090 B 331 K VA1-KC	○	○	○	○	○
DE7090 B 471 K VA1-KC	○	○	○	○	○
DE7090 B 102 K VA1-KC	○	○	○	○	○
DE7090 F 152 M VA1-KC	○	○	○	○	○
DE7100 F 222 M VA1-KC	○	○	○	○	○
DE7120 F 332 M VA1-KC	○	○	○	○	○
DE7120 F 392 M VA1-KC	○	○	○	○	○
DE7150 F 472 M VA1-KC	○	○	○	○	○
DE7100 F 472 M VA1-KC	○	○	○	○	○
DE7150 F 103 M VA1-KC	○	○	○	○	○
DE7100 FZ 472 P VA1-KC	—	○	○	—	○
DE7150 FZ 103 P VA1-KC	—	○	○	—	○
AC Rated Voltage	250	250	125	250	250

TYPE KH

Part Number	Recognized Standard No.				
	IEC384-14 2nd Edition (1993)	UL1414	C22.2 No. 1	BSI EN60065	AS3250
	X1/Y2	—	—	X1/Y2	—
DE0807 B 101K-KH	○	○	○	○	○
DE0807 B 151K-KH	○	○	○	○	○
DE0807 B 221K-KH	○	○	○	○	○
DE0807 B 331K-KH	○	○	○	○	○
DE0807 B 471K-KH	○	○	○	○	○
DE0907 B 681K-KH	○	○	○	○	○
DE0807 E 102M-KH	○	○	○	○	○
DE0907 E 152M-KH	○	○	○	○	○
DE1007 E 222M-KH	○	○	○	○	○
DE1207 E 332M-KH	○	○	○	○	○
DE1307 E 472M-KH	○	○	○	○	○
DE1607 F 103M-KH	○	○	○	○	○
AC Rated Voltage	250	250	125	250	250

TYPE KD

Part Number	Recognized Standard No.			
	IEC384-14 2nd Edition (1993)	UL1414	C22.2 No. 0, No. 1	BSI EN60065
	X1/Y1	—	—	X1/Y1
DE1010 B 101 K ACT4K-KD	○	○	○	○
DE1010 B 151 K ACT4K-KD	○	○	○	○
DE1010 B 221 K ACT4K-KD	○	○	○	○
DE1010 B 331 K ACT4K-KD	○	○	○	○
DE1010 B 471 K ACT4K-KD	○	○	○	○
DE1010 E 681 M ACT4K-KD	○	○	○	○
DE1110 E 102 M ACT4K-KD	○	○	○	○
DE1410 E 222 M ACT4K-KD	○	○	○	○
DE1610 E 332 M ACT4K-KD	○	○	○	○
DE1710 E 392 M ACT4K-KD	○	○	○	○
DE1910 E 472 M ACT4K-KD	○	○	○	○
AC Rated Voltage	250	250	125	250

Notes:

- (1) ○: Recognized —: Not Recognized
- (2) X capacitors are for use only in positions where failure of the capacitor would not expose anyone to electrical shock. UL/CSA designates the "X" type capacitor for "Across-The-Line" applications.
- (3) Y capacitors are for use in positions where failure of the capacitor may expose someone to dangerous electrical shock. UL/CSA designates the "Y" type capacitor for "Antenna Coupling" and "Line-By-Pass" applications.
- (4) IEC384-14 2nd Edition (1993) – Approval Standard for SEMKO, VDE, IMQ, SEV, FIMKO, NEMKO, DEMKO.

CERAMIC CAPACITORS SAFETY RECOGNIZED CAPACITORS-KC, KH & KD TYPE SPECIFICATIONS



Discharge Test II

A single layer of cheesecloth is to be placed around the body of the test capacitor. Each sample is to be subjected to 4 discharges from a dump capacitor charged to a voltage that, when discharged, places 5KV (KC, KH, KD type) across Ct. The interval between successive discharges is to be 5 seconds. A 240V, 60Hz potential is to be applied across Ct and is to be maintained for 30 seconds after the fourth discharge, unless the circuit is otherwise opened sooner due to breakdown of Ct. The test circuit is shown as Figure 1 and the test results shall meet the parameters of Table 1.

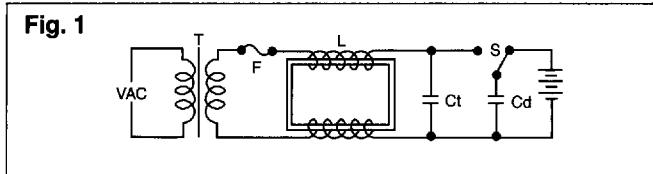

The direct current supply is to be adjusted to provide a potential in accordance with the following.

$$VDC = \frac{5000(Cd + Ct)}{Cd} \text{ (V)}$$

- VDC : Variable direct-current voltage source
- S : High-voltage switch
- L : Choke coil of approximately 3mH and 0.03Ω
- F : Plug fuse rate 30A and 250V
- VAC : Supply source rated 240V, 60Hz and 30A
- Ct : Capacitor under test
- Cd : Dump capacitor

Capacitance Value(s) and Dissipation Factor(s) are as follows:

TABLE 1

Item	Series	
	KC, KH, KD	
Cap. Value of Ct	0 to 0.005μF	0.0051 to 0.05μF
Cap. Value of Cd	0.005μF	0.05μF
D.F.	0.5% max.	
Appearance	The cheesecloth around capacitor shall not glow or flame.	

Flame Test

Capacitor shall be subjected to Figure 2 for 15 sec. and then removed for 15 sec. for 5 cycles.

- 1st to 4th cycles : 30 sec. max.
- 5th cycle : 60 sec. max. with flame extinguished

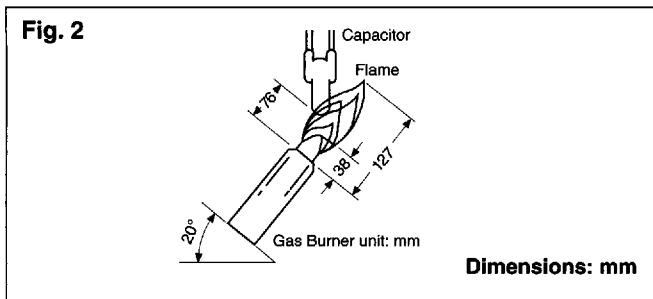

Encapsulation

Conformally coated in epoxy resin, which conforms to UL94V-φ.

Active Flammability

The cheesecloth shall not be on fire when the following testing method is performed.

Testing Method

The specimens shall be individually wrapped in at least two complete layers of cheesecloth. The specimens shall be subjected to 20 discharges. The interval between successive discharges shall be 5 sec. The VAC shall be maintained for 2 min. after the last discharge. See Figures 3 & 4 below.

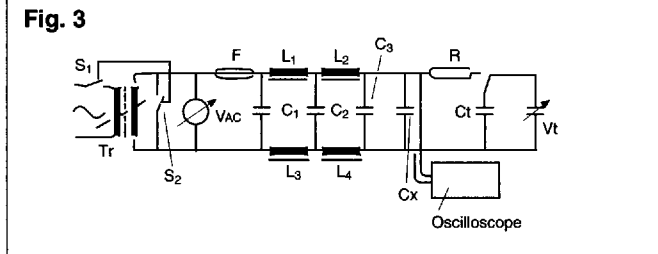

- C_{1,2} : 1μF ± 10%, C₃: 0.33μF ± 5% 10KV
- L₁₋₄ : 1.5mH ± 20% 16A Rod core choke
- R : 100Ω ± 2%, Ct: 3μF ± 5% 10KV
- VAC : V_R ± 5%, V_R: Rated working voltage
- Cx : Capacitor, F: Fuse, Rated 10A
- Vt : Voltage applied to Ct

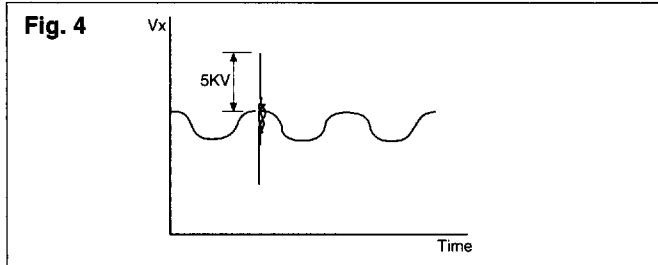

Passive Flammability

The test specimen shall be held in the flame and the time shall not exceed 30 sec. The tissue paper shall not ignite. See Figure 5 below.

Testing Method

The capacitor under test shall be held in the flame in the position which best promotes burning. Each specimen shall only be exposed once to the flame. Time of exposure to flame: 30sec.

- Length of flame : 12 ± 1mm
- Gas burner : Length 35mm min.
- Inside diameter : 0.5 ± 0.1mm
- Outside diameter : 0.9mm max.
- Gas : Butane gas purity 95% min.

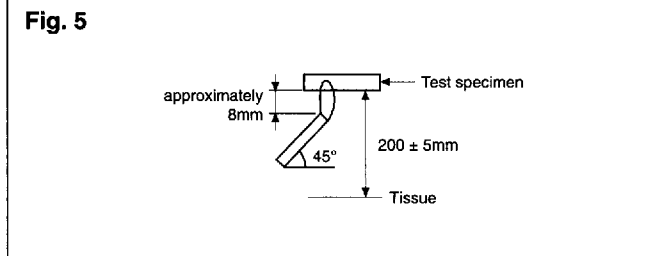

CERAMIC CAPACITORS SAFETY RECOGNIZED CAPACITORS—KC, KH & KD TYPE SPECIFICATIONS



Operating Temperature Range

-25°C to +85°C (KC and KD)
-25°C to +125°C (KH except UL, CSA and VDE)

Capacitance

Measured at 1 ± 0.1 KHz, 5Vrms max. and 20°C

Dissipation Factor (D.F.)

Measured at 1 ± 0.1 KHz, 5Vrms max. and 20°C

TC	D.F.
B	≤2.5%
E	≤2.5%
F, FZ	≤5.0%

Insulation Resistance (I.R.)

10,000MΩ min. (at 500V DC for 1 minute).

Dielectric Strength

Between both leads:

KC and KH Type : 2,600 VAC for 1 minute.
KD Type : 4,000 VAC for 1 minute.

Temperature Characteristics

TC	Change Over Temp. Range
B	±10%
E	+20, -55%
F	+30, -80%
FZ	+30, -85% (-10°C to +60°C)

Humidity

Capacitor shall be subjected to $40 \pm 2^\circ\text{C}$ and a relative humidity of 90 to 95% for 500 ± 12 hours. After placing at room temperature for 1 or 2 hours, conditions shall be as in Table 1.

TABLE 1

Item	Series	
	KC	KH, KD
Appearance	No physical damage	No physical damage
I.R.	B, F: 3000MΩ min. FZ: 1500MΩ min.	3000MΩ min.
Dielectric Strength	See above	

Life Test

Capacitor shall be placed in a circulating air chamber under the following conditions and meet the parameters of Table 2 measured 24 ± 2 hours after testing:

KC Type : $85 \pm 2^\circ\text{C}$, 50% RH max., Apply 425 VAC for 1000 hours increasing to 1000 VAC for 0.1 seconds once each hour.

KH Type : $125 \pm 2^\circ\text{C}$, 50% RH max., Apply 425 VAC for 1000 hours increasing to 1000 VAC for 0.1 seconds once each hour.

KD Type : $85 \pm 2^\circ\text{C}$, 50% RH max., Apply 800 VAC for 1500 hours increasing to 1600 VAC for 0.1 seconds once each hour.

TABLE 2

Item	Series	
	KC	KH, KD
Appearance	No physical damage	No physical damage
I.R.	B, F: 3000MΩ min. FZ: 1500MΩ min.	3000MΩ min.
Dielectric Strength	See dielectric strength item at left	
Discharge Test II	See page 95	

Impulse Voltage Test

After the capacitors are subjected to the life test, each individual capacitor shall be subjected to a 5kV (KD : 8kV) impulse voltage as shown in Figure 1.

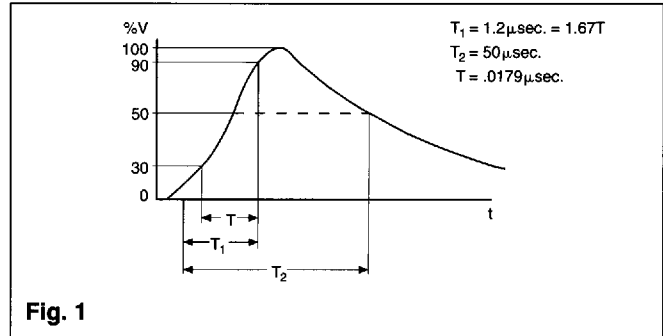

Discharge Test 1

As in Figure 2, discharge is made 50 times at 5 second intervals from Cd charged to 10kV DC (KC, KH, KD type); the measured results shall meet the parameters of Table 3.

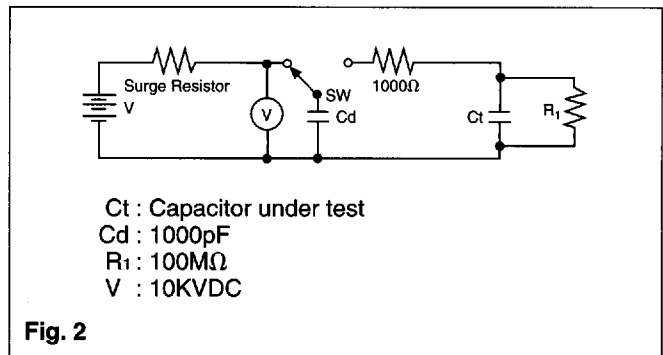

Ct : Capacitor under test
Cd : 1000pF
R1 : 100MΩ
V : 10KVDC

TABLE 3

Item	Series
	KC, KH, KD
Appearance	No physical damage
I.R.	1000MΩ min.
Dielectric Strength	See dielectric strength item at left