

MITSUBISHI LSTTLs
M74LS32P

QUADRUPLE 2-INPUT POSITIVE OR GATES

DESCRIPTION

The M74LS32P is a semiconductor integrated circuit containing 4 dual-input positive OR and negative AND gates.

FEATURES

- High breakdown input voltage ($V_I \geq 15V$)
- Low power dissipation ($P_D = 20mW$ typical)
- High speed ($t_{pd} = 7ns$ typical)
- Low output impedance
- Wide operating temperature range ($T_a = -20 \sim +75^\circ C$)

APPLICATION

General purpose, for use in industrial and consumer equipment.

FUNCTIONAL DESCRIPTION

The use of Schottky TTL technology has enabled the achievement of input high breakdown voltage, high speed, low power dissipation, and high fan-out.

When either or both of the inputs A and B is/are high, output Y is high, and when both A and B are low, Y is low.

FUNCTION TABLE

A	B	Y
L	L	L
H	L	H
L	H	H
H	H	H

PIN CONFIGURATION (TOP VIEW)

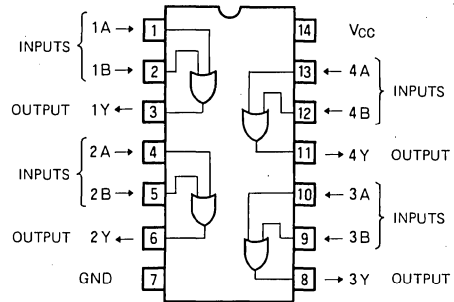

Outline 14P4

CIRCUIT SCHEMATIC (EACH GATE)

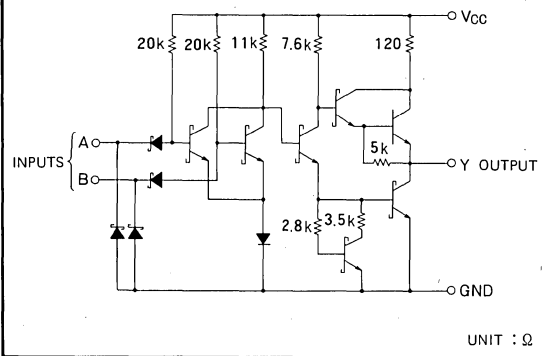

ABSOLUTE MAXIMUM RATINGS ($T_a = -20 \sim +75^\circ C$, unless otherwise noted)

Symbol	Parameter	Conditions	Limits	Unit
V_{CC}	Supply voltage		$-0.5 \sim +7$	V
V_I	Input voltage		$-0.5 \sim +15$	V
V_O	Output voltage	High-level state	$-0.5 \sim V_{CC}$	V
T_{opr}	Operating free-air ambient temperature range		$-20 \sim +75$	$^\circ C$
T_{stg}	Storage temperature range		$-65 \sim +150$	$^\circ C$

QUADRUPLE 2-INPUT POSITIVE OR GATES

RECOMMENDED OPERATING CONDITIONS ($T_a = -20 \sim +75^\circ\text{C}$, unless otherwise noted)

Symbol	Parameter		Limits			Unit
			Min	Typ	Max	
V_{CC}	Supply voltage		4.75	5	5.25	V
I_{OH}	High-level output current	$V_{OH} \geq 2.7\text{V}$	0		-400	μA
I_{OL}	Low-level output current	$V_{OL} \leq 0.4\text{V}$	0		4	mA
		$V_{OL} \leq 0.5\text{V}$	0		8	mA

ELECTRICAL CHARACTERISTICS ($T_a = -20 \sim +75^\circ\text{C}$, unless otherwise noted)

Symbol	Parameter	Test conditions	Limits			Unit
			Min	Typ*	Max	
V_{IH}	High-level input voltage		2			V
V_{IL}	Low-level input voltage				0.8	V
V_{IC}	Input clamp voltage	$V_{CC} = 4.75\text{V}$, $I_{IC} = -18\text{mA}$			-1.5	V
V_{OH}	High-level output voltage	$V_{CC} = 4.75\text{V}$, $V_I = 2\text{V}$ $I_{OH} = -400\mu\text{A}$	2.7	3.4		V
V_{OL}	Low-level output voltage	$V_{CC} = 4.75\text{V}$ $V_I = 0.8\text{V}$		0.25	0.4	V
			$I_{OL} = 4\text{mA}$		0.35	0.5
I_{IH}	High-level input current	$V_{CC} = 5.25\text{V}$, $V_I = 2.7\text{V}$			20	μA
		$V_{CC} = 5.25\text{V}$, $V_I = 10\text{V}$			0.1	mA
I_{IL}	Low-level input current	$V_{CC} = 5.25\text{V}$, $V_I = 0.4\text{V}$			-0.4	mA
I_{OS}	Short-circuit output current (Note 1)	$V_{CC} = 5.25\text{V}$, $V_O = 0\text{V}$	-20		-100	mA
I_{CCH}	Supply current, all outputs high	$V_{CC} = 5.25\text{V}$, $V_I = 4.5\text{V}$		3.1	6.2	mA
I_{CCL}	Supply current, all outputs low	$V_{CC} = 5.25\text{V}$, $V_I = 0\text{V}$		4.9	9.8	mA

* : All typical values are at $V_{CC} = 5\text{V}$, $T_a = 25^\circ\text{C}$.

Note 1: All measurements should be done quickly, and not more than one output should be shorted at a time.

SWITCHING CHARACTERISTICS ($V_{CC} = 5\text{V}$, $T_a = 25^\circ\text{C}$, unless otherwise noted)

Symbol	Parameter	Test conditions	Limits			Unit
			Min	Typ	Max	
t_{PLH}	Low-to-high-level output propagation time	$C_L = 15\text{pF}$ (Note 2)		7	22	ns
t_{PHL}	High-to-low-level output propagation time			7	22	ns

Note 2: Measurement circuit

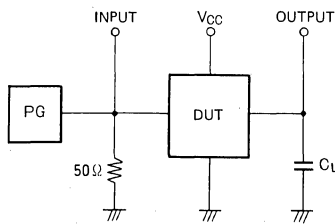

- The pulse generator (PG) has the following characteristics:
 $PRR = 1\text{MHz}$, $t_r = 6\text{ns}$, $t_f = 6\text{ns}$, $t_w = 500\text{ns}$,
 $V_P = 3\text{V}_{P-P}$, $Z_0 = 50\Omega$
- C_L includes probe and jig capacitance.

TIMING DIAGRAM (Reference level = 1.3V)

