

SN54365A THRU SN54368A, SN54LS365A THRU SN54LS368A SN74365A THRU SN74368A, SN74LS365A THRU SN74LS368A HEX BUS DRIVERS WITH 3-STATE OUTPUTS

DECEMBER 1983—REVISED MARCH 1988

- 3-State Outputs Drive Bus Lines or Buffer Memory Address Registers
 - Choice of True or Inverting Outputs
 - Package Options Include Plastic "Small Outline" Packages, Ceramic Chip Carriers and Flat Packages, and Plastic and Ceramic DIPs
 - Dependable Texas Instruments Quality and Reliability
- '365A, '367A, 'LS365A, 'LS367A True Outputs
'366A, '368A, 'LS366A, 'LS368A Inverting Outputs

description

These Hex buffers and line drivers are designed specifically to improve both the performance and density of three-state memory address drivers, clock drivers, and bus oriented receivers and transmitters. The designer has choice of selected combinations of inverting and noninverting outputs, symmetrical \bar{G} (active-low control) inputs.

These devices feature high fan-out, improved fan-in, and can be used to drive terminated lines down to 133 ohms.

The SN54365A thru SN54368A and SN54LS365A thru SN54LS368A are characterized for operation over the full military temperature range of -55°C to 125°C . The SN74365A thru SN74368A and SN74LS365A thru SN74LS368A are characterized for operation from 0°C to 70°C .

SN54365A, 366A, SN54LS365A, 366A . . . J PACKAGE
SN74365A, 366A . . . N PACKAGE
SN74LS365A, SN74LS366A . . . D OR N PACKAGE

(TOP VIEW)

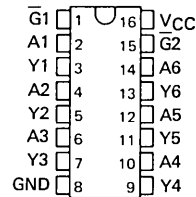

SN54LS365A, SN54LS366A . . . FK PACKAGE

(TOP VIEW)

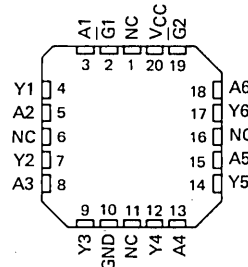

SN54367A, 368A, SN54LS367A, 368A . . . J PACKAGE
SN74367A, 368A . . . N PACKAGE
SN74LS367A, SN74LS368A . . . D OR N PACKAGE

(TOP VIEW)

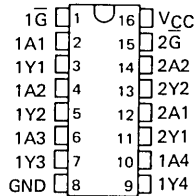

SN54LS367A, SN54LS368A . . . FK PACKAGE

(TOP VIEW)

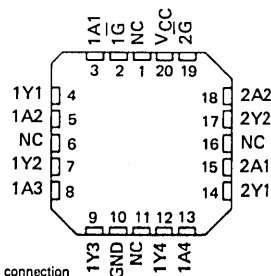

NC - No internal connection



TTL Devices

PRODUCTION DATA documents contain information current as of publication date. Products conform to specifications per the terms of Texas Instruments standard warranty. Production processing does not necessarily include testing of all parameters.

TEXAS INSTRUMENTS

POST OFFICE BOX 655012 • DALLAS, TEXAS 75265

2-873

**SN54365A THRU SN54368A, SN54LS365A THRU SN54LS368A
SN74365A THRU SN74368A, SN74LS365A THRU SN74LS368A
HEX BUS DRIVERS WITH 3-STATE OUTPUTS**

schematics of inputs and outputs

'365A thru '368A

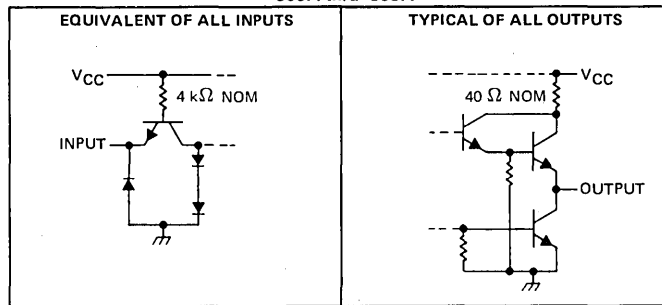

'LS365A thru 'LS368A

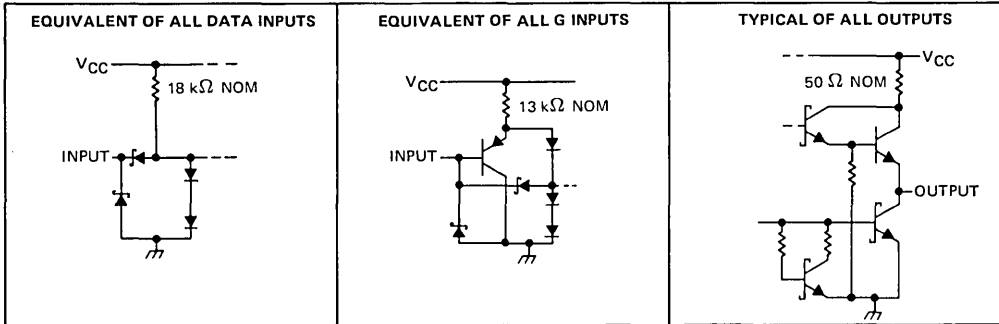

2
TTL Devices

logic diagrams (positive logic)

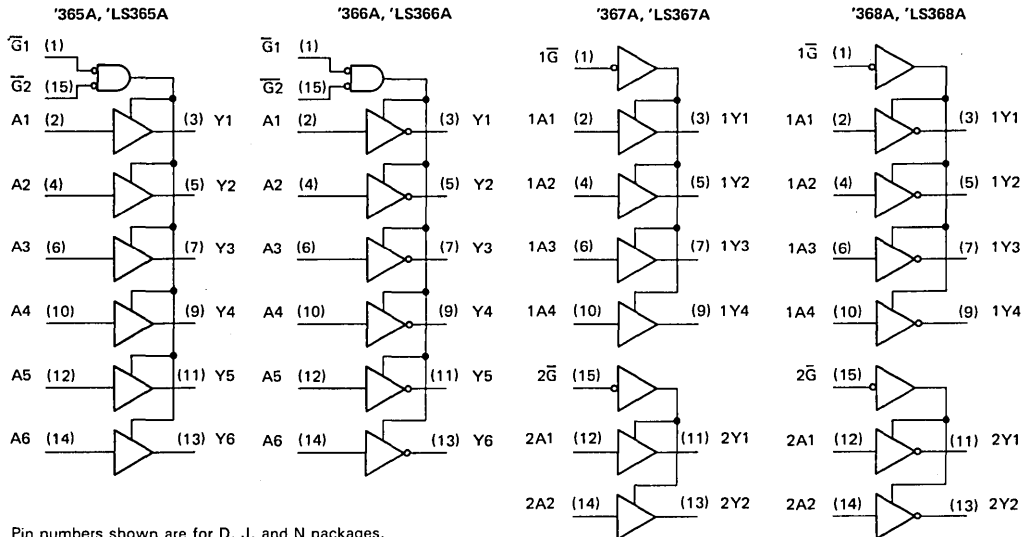

**SN54365A THRU SN54368A, SN54LS365A THRU SN54LS368A
SN74365A THRU SN74368A, SN74LS365A THRU SN74LS368A
HEX BUS DRIVERS WITH 3-STATE OUTPUTS**

logic symbols†

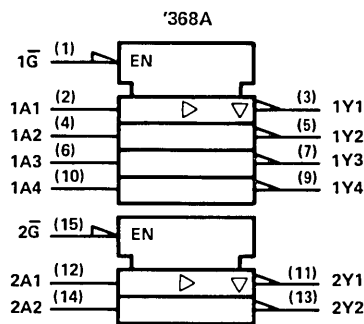
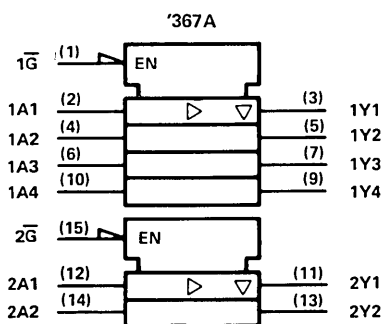
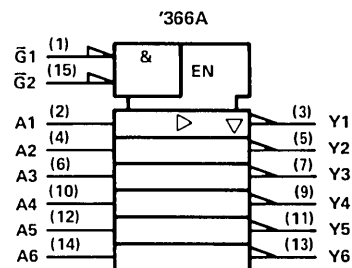
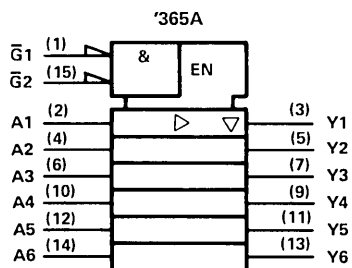

†These symbols are in accordance with ANSI/IEEE Std 91-1984 and IEC Publication 617-12. Pin numbers shown are for D, J, and N packages.

absolute maximum ratings over operating free-air temperature range (unless otherwise noted)

Supply voltage, V_{CC} (see Note 1)	7 V
Input voltage: '365A, '366A, '367A, '368A	5.5 V
'LS365A, 'LS366A, 'LS367A, 'LS368A	7 V
Voltage applied to a disabled 3-state output	5.5 V
Operating free-air temperature: SN54'	-55°C to 125°C
SN74'	0°C to 70°C
Storage temperature range	-65°C to 150°C

NOTE 1: Voltage values are with respect to network ground terminal.

**SN54365A, SN54367A
SN74365A, SN74367A
HEX BUS DRIVERS WITH 3-STATE OUTPUTS**

recommended operating conditions

	SN54365A SN54367A			SN74365A SN74367A			UNIT
	MIN	NOM	MAX	MIN	NOM	MAX	
V _{CC} Supply voltage	4.5	5	5.5	4.75	5	5.25	V
V _{IH} High-level input voltage	2			2			V
V _{IL} Low-level input voltage	0.8			0.8			V
I _{OH} High-level output current	-2			-5.2			mA
I _{OL} Low-level output current	32			32			mA
T _A Operating free-air temperature	-55	125		0	70		°C

electrical characteristics over recommended operating free-air temperature range (unless otherwise noted)

PARAMETER	TEST CONDITIONS†	SN54365A SN54367A			SN74365A SN74367A			UNIT	
		MIN	TYP‡	MAX	MIN	TYP‡	MAX		
V _{IK}	V _{CC} = MIN, I _I = -12 mA	-1.5			-1.5			V	
V _{OH}	V _{CC} = MIN, V _{IH} = 2 V, V _{IL} = 0.8 V, I _{OH} = MAX	2.4	3.3		2.4	3.1	V		
V _{OL}	V _{CC} = MIN, V _{IH} = 2 V, V _{IL} = 0.8 V, I _{OL} = 32 mA	0.4			0.4			V	
I _{OZ}	V _{CC} = MAX, V _{IH} = 2 V, V _{IL} = 0.8 V, V _O = 2.4 V	40			40			μA	
	V _{CC} = MAX, V _{IH} = 2 V, V _{IL} = 0.8 V, V _O = 0.4 V	-40			-40				
I _I	V _{CC} = MAX, V _I = 5.5 V	1			1			mA	
I _{IH}	V _{CC} = MAX, V _I = 2.4 V	40			40			μA	
I _{IL}	A Inputs	V _{CC} = MAX, V _I = 0.5 V, Either \bar{C} input at 2 V	-40			-40			μA
		V _{CC} = MAX, V _I = 0.4 V, Both \bar{C} inputs at 0.4 V	-1.6			-1.6			
	\bar{C} Inputs	V _{CC} = MAX, V _I = 0.4 V	-1.6			-1.6			mA
I _{OS} §	V _{CC} = MAX	-40	-130		-40	-130	mA		
I _{CC}	V _{CC} = MAX, Data inputs = 0 V, Output controls = 4.5 V	65 85			65 85			mA	

† For conditions shown as MIN or MAX, use the appropriate value specified under recommended operating conditions.

‡ All typical values are at V_{CC} = 5 V, T_A = 25°C.

§ Not more than one output should be shorted at a time.

switching characteristics, V_{CC} = 5 V, T_A = 25°C (see note 2)

PARAMETER	FROM (INPUT)	TO (OUTPUT)	TEST CONDITIONS	MIN	TYP	MAX	UNIT
t _{PLH}	Any	Y	R _L = 400 Ω, C _L = 50 pF	16			ns
t _{PHL}				22			ns
t _{PZH}				35			ns
t _{PZL}				37			ns
t _{PHZ}				11			ns
t _{PLZ}				27			ns

NOTE 2: Load circuits and voltage waveforms are shown in Section 1.

SN54366A, SN54368A
SN74366A, SN74368A
HEX BUS DRIVERS WITH 3-STATE OUTPUTS

recommended operating conditions

	SN54366A SN54368A			SN74366A SN74368A			UNIT
	MIN	NOM	MAX	MIN	NOM	MAX	
V _{CC} Supply voltage	4.5	5	5.5	4.75	5	5.25	V
V _{IH} High-level input voltage	2			2			V
V _{IL} Low-level input voltage			0.8			0.8	V
I _{OH} High-level output current			-2			-5.2	mA
I _{OL} Low-level output current			32			32	mA
T _A Operating free-air temperature	-55		125	0		70	°C

electrical characteristics over recommended operating free-air temperature range (unless otherwise noted)

PARAMETER	TEST CONDITIONS†	SN54366A SN54368A			SN74366A SN74368A			UNIT
		MIN	TYP‡	MAX	MIN	TYP‡	MAX	
V _{IK}	V _{CC} = MIN, I _I = -12 mA			-1.5			-1.5	V
V _{OH}	V _{CC} = MIN, V _{IH} = 2 V, V _{IL} = 0.8 V, I _{OH} = MAX	2.4	3.3		2.4	3.1		V
V _{OL}	V _{CC} = MIN, V _{IH} = 2 V, V _{IL} = 0.8 V, I _{OL} = 32 mA			0.4			0.4	V
I _{OZ}	V _{CC} = MAX, V _{IH} = 2 V, V _{IL} = 0.8 V, V _O = 2.4 V			40			40	μA
	V _{CC} = MAX, V _{IH} = 2 V, V _{IL} = 0.8 V, V _O = 0.4 V			-40			-40	
I _I	V _{CC} = MAX, V _I = 5.5 V			1			1	mA
I _{IH}	V _{CC} = MAX, V _I = 2.4 V			40			40	μA
I _{IL}	A Inputs	V _{CC} = MAX, V _I = 0.5 V, Either \bar{G} input at 2 V			-40		-40	μA
		V _{CC} = MAX, V _I = 0.4 V, Both \bar{G} inputs at 0.4 V			-1.6		-1.6	mA
	\bar{G} Inputs	V _{CC} = MAX, V _I = 0.4 V			-1.6		-1.6	mA
I _{OS} §	V _{CC} = MAX	-40		-130	-40		-130	mA
I _{CC}	V _{CC} = MAX, Data inputs = 0 V, Output controls = 4.5 V,		59	77		59	77	mA

† For conditions shown as MIN or MAX, use the appropriate value specified under recommended operating conditions.

‡ All typical values are at V_{CC} = 5 V, T_A = 25°C.

§ Not more than one output should be shorted at a time.

switching characteristics, V_{CC} = 5 V, T_A = 25°C (see note 2)

PARAMETER	FROM (INPUT)	TO (OUTPUT)	TEST CONDITIONS	MIN	TYP	MAX	UNIT
t _{PLH}	Any	Y	R _L = 400 Ω, C _L = 50 pF			17	ns
t _{PHL}						16	ns
t _{PZH}						35	ns
t _{PZL}						37	ns
t _{PHZ}						11	ns
t _{PLZ}						27	ns

NOTE 2: Load circuits and voltage waveforms are shown in Section 1.



TTL Devices

**SN54LS365A, SN54LS367A
SN74LS365A, SN74LS367A
HEX BUS DRIVERS WITH 3-STATE OUTPUTS**

recommended operating conditions

	SN54LS365A SN54LS367A			SN74LS365A SN74LS367A			UNIT
	MIN	NOM	MAX	MIN	NOM	MAX	
V _{CC} Supply voltage	4.5	5	5.5	4.75	5	5.25	V
V _{IH} High-level input voltage	2			2			V
V _{IL} Low-level input voltage	0.7			0.8			V
I _{OH} High-level output current	-1			-2.6			mA
I _{OL} Low-level output current	12			24			mA
T _A Operating free-air temperature	-55			125			°C

electrical characteristics over recommended operating free-air temperature range (unless otherwise noted)

PARAMETER	TEST CONDITIONS†	SN54LS365A SN54LS367A			SN74LS365A SN74LS367A			UNIT	
		MIN	TYP‡	MAX	MIN	TYP‡	MAX		
V _{IK}	V _{CC} = MIN, I _I = -18 mA	-1.5			-1.5			V	
V _{OH}	V _{CC} = MIN, V _{IH} = 2 V, V _{IL} = MAX, I _{OH} = MAX	2.4	3.3		2.4	3.1		V	
V _{OL}	V _{CC} = MIN, V _{IH} = 2 V, V _{IL} = MAX, I _{OL} = 12 mA	0.25	0.4		0.25	0.4		V	
	V _{CC} = MIN, V _{IH} = 2 V, V _{IL} = 0.8 V, I _{OL} = 24 mA				0.35	0.5		V	
I _{OZ}	V _{CC} = MAX, V _{IH} = 2 V, V _{IL} = MAX, V _O = 2.4 V	20			20			μA	
	V _{CC} = MAX, V _{IH} = 2 V, V _{IL} = MAX, V _O = 0.4 V	-20			-20				
I _I	V _{CC} = MAX, V _I = 7 V	0.1			0.1			mA	
I _{IH}	V _{CC} = MAX, V _I = 2.7 V	20			20			μA	
I _{IL}	A Inputs	V _{CC} = MAX, V _I = 0.5 V, Either \bar{G} input at 2 V	-20			-20			μA
		V _{CC} = MAX, V _I = 0.4 V, Both \bar{G} inputs at 0.4 V	-0.4			-0.4			
	\bar{G} Inputs	V _{CC} = MAX, V _I = 0.4 V	-0.2			-0.2			mA
I _{OS} §	V _{CC} = MAX	-40	-225		-40	-225		mA	
I _{CC}	V _{CC} = MAX, Data inputs = 0 V, Output controls = 4.5 V,	14	24		14	24		mA	

† For conditions shown as MIN or MAX, use the appropriate value specified under recommended operating conditions.

‡ All typical values are at V_{CC} = 5 V, T_A = 25°C.

§ Not more than one output should be shorted at a time, and the duration of the short circuit should not exceed one second.

2

TTL Devices

SN54LS365A, SN54LS367A
SN74LS365A, SN74LS367A
HEX BUS DRIVERS WITH 3-STATE OUTPUTS

switching characteristics, $V_{CC} = 5\text{ V}$, $T_A = 25^\circ\text{C}$ (see note 2)

PARAMETER	FROM (INPUT)	TO (OUTPUT)	TEST CONDITIONS	MIN	TYP	MAX	UNIT
t_{PLH}	Any	Y	$R_L = 667\ \Omega$, $C_L = 45\ \text{pF}$	10	16	ns	
t_{PHL}				9	22	ns	
t_{PZH}				19	35	ns	
t_{PZL}				24	40	ns	
t_{PHZ}			$R_L = 667\ \Omega$, $C_L = 5\ \text{pF}$	30	ns		
t_{PLZ}				35	ns		

NOTE 2: Load circuits and voltage waveforms are shown in Section 1.

2

TTL Devices

SN54LS366A, SN54LS368A
SN74LS366A, SN74LS368A
HEX BUS DRIVERS WITH 3-STATE OUTPUTS

recommended operating conditions

	SN54LS366A SN54LS368A			SN74LS366A SN74LS368A			UNIT
	MIN	NOM	MAX	MIN	NOM	MAX	
V _{CC} Supply voltage	4.5	5	5.5	4.75	5	5.25	V
V _{IH} High-level input voltage	2			2			V
V _{IL} Low-level input voltage			0.7			0.8	V
I _{OH} High-level output current			-1			-2.6	mA
I _{OL} Low-level output current			12			24	mA
T _A Operating free-air temperature	-55		125	0		70	°C

electrical characteristics over recommended operating free-air temperature range (unless otherwise noted)

2

TTL Devices

PARAMETER	TEST CONDITIONS †	SN54LS366A SN54LS368A			SN74LS366A SN74LS368A			UNIT
		MIN	TYP ‡	MAX	MIN	TYP ‡	MAX	
V _{IK}	V _{CC} = MIN, I _I = -18 mA			-1.5			-1.5	V
V _{OH}	V _{CC} = MIN, V _{IH} = 2 V, V _{IL} = MAX, I _{OH} = MAX	2.4	3.3		2.4	3.1		V
V _{OL}	V _{CC} = MIN, V _{IH} = 2 V, V _{IL} = MAX, I _{OL} = 12 mA		0.25	0.4		0.25	0.4	V
	V _{CC} = MIN, V _{IH} = 2 V, V _{IL} = 0.8 V, I _{OL} = 24 mA					0.35	0.5	
I _{OZ}	V _{CC} = MAX, V _{IH} = 2 V, V _{IL} = MAX, V _O = 2.4 V			20			20	μA
	V _{CC} = MAX, V _{IH} = 2 V, V _{IL} = MAX, V _O = 0.4 V			-20			-20	
I _I	V _{CC} = MAX, V _I = 7 V			0.1			0.1	mA
I _{IH}	V _{CC} = MAX, V _I = 2.7 V			20			20	μA
I _{IL}	A Inputs	V _{CC} = MAX, V _I = 0.5 V, Either \bar{G} input at 2 V			-20		-20	μA
		V _{CC} = MAX, V _I = 0.4 V, Both \bar{G} inputs at 0.4 V			-0.4		-0.4	
	\bar{G} Inputs	V _{CC} = MAX, V _I = 0.4 V			-0.2		-0.2	
I _{OS} §	V _{CC} = MAX	-40		-225	-40		-225	mA
I _{CC}	V _{CC} = MAX, Data inputs = 0 V, Output controls = 4.5 V,		12	21		12	21	mA

† For conditions shown as MIN or MAX, use the appropriate value specified under recommended operating conditions.

‡ All typical values are at V_{CC} = 5 V, T_A = 25°C.

§ Not more than one output should be shorted at a time, and the duration of the short circuit should not exceed one second.

**SN54LS366A, SN54LS368A
SN74LS366A, SN74LS368A
HEX BUS DRIVERS WITH 3-STATE OUTPUTS**

switching characteristics, $V_{CC} = 5\text{ V}$, $T_A = 25^\circ\text{C}$ (see note 2)

PARAMETER	FROM (INPUT)	TO (OUTPUT)	TEST CONDITIONS	MIN	TYP	MAX	UNIT	
t_{PLH}	Any	Y	$R_L = 667\ \Omega$, $C_L = 45\ \text{pF}$		7	15	ns	
t_{PHL}					12	18	ns	
t_{PZH}					18	35	ns	
t_{PZL}					28	45	ns	
t_{PHZ}							32	ns
t_{PLZ}					$R_L = 667\ \Omega$, $C_L = 5\ \text{pF}$			35

NOTE 2: Load circuits and voltage waveforms are shown in Section 1.