

# SN5430, SN54LS30, SN54S30, SN7430, SN74LS30, SN74S30 8-INPUT POSITIVE-NAND GATES

DECEMBER 1983—REVISED MARCH 1988

- Package Options Include Plastic "Small Outline" Packages, Ceramic Chip Carriers and Flat Packages, and Plastic and Ceramic DIPs
- Dependable Texas Instruments Quality and Reliability

## description

These devices contain a single 8-input NAND gate.

The SN5430, SN54LS30, and SN54S30 are characterized for operation over the full military range of -55°C to 125°C. The SN7430, SN74LS30, and SN74S30 are characterized for operation from 0°C to 70°C.

FUNCTION TABLE

INPUTS A THRU H	OUTPUT Y
All inputs H	L
One or more inputs L	H

## logic diagram

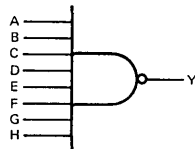

## positive logic

$$Y = \overline{A \cdot B \cdot C \cdot D \cdot E \cdot F \cdot G \cdot H} \quad \text{or}$$

$$Y = \overline{A} + \overline{B} + \overline{C} + \overline{D} + \overline{E} + \overline{F} + \overline{G} + \overline{H}$$

## logic symbol†

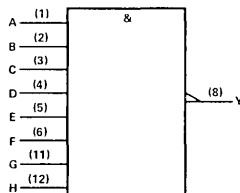

†This symbol is in accordance with ANSI/IEEE Std 91-1984 and IEC Publication 617-12.

Pin numbers shown are for D, J, N, and W packages.

SN5430 . . . J PACKAGE  
SN54LS30, SN54S30 . . . J OR W PACKAGE  
SN7430 . . . N PACKAGE  
SN74LS30, SN74S30 . . . D OR N PACKAGE  
(TOP VIEW)

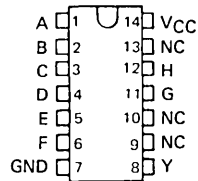

SN5430 . . . W PACKAGE  
(TOP VIEW)

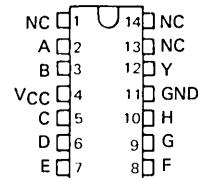

SN54LS30, SN54S30 . . . FK PACKAGE  
(TOP VIEW)

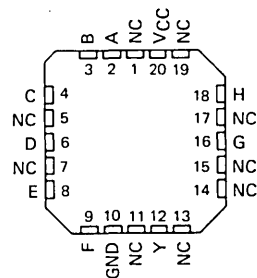

NC - No internal connection

2  
TTL Devices

PRODUCTION DATA documents contain information current as of publication date. Products conform to specifications per the terms of Texas Instruments standard warranty. Production processing does not necessarily include testing of all parameters.

TEXAS  
INSTRUMENTS

POST OFFICE BOX 655012 • DALLAS, TEXAS 75265

**SN5430, SN54LS30, SN54S30,  
SN7430, SN74LS30, SN74S30  
8-INPUT POSITIVE-NAND GATES**

schematics (each gate)

**2**

TTL Devices

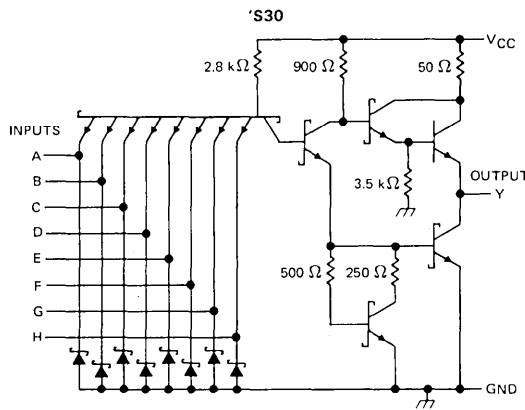
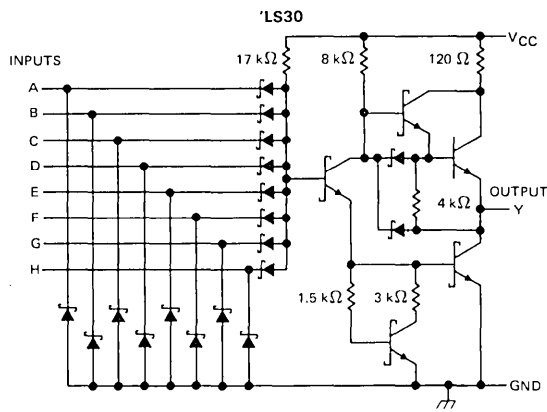
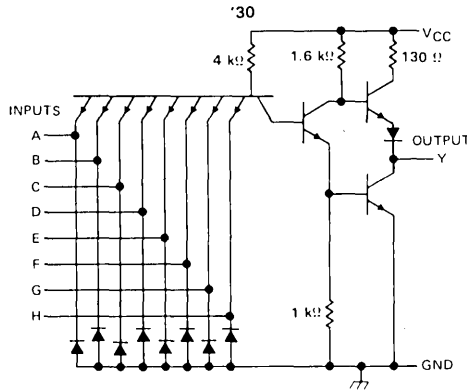

Resistor values shown are nominal.

**SN5430, SN7430**  
**8-INPUT POSITIVE-NAND GATES**

**absolute maximum ratings over operating free-air temperature range (unless otherwise noted)**

Supply voltage, $V_{CC}$ (see Note 1) .....	7 V
Input voltage .....	5.5 V
Operating free-air temperature range: SN5430 .....	-55°C to 125°C
SN7430 .....	0°C to 70°C
Storage temperature range .....	-65°C to 150°C

NOTE 1: Voltage values are with respect to network ground terminal.

**recommended operating conditions**

	SN5430			SN7430			UNIT
	MIN	NOM	MAX	MIN	NOM	MAX	
$V_{CC}$ Supply voltage	4.5	5	5.5	4.75	5	5.25	V
$V_{IH}$ High-level input voltage	2			2			V
$V_{IL}$ Low-level input voltage			0.8			0.8	V
$I_{OH}$ High-level output current			-0.4			-0.4	mA
$I_{OL}$ Low-level output current			16			16	mA
$T_A$ Operating free-air temperature	-55		125	0		70	°C



TTL Devices

**electrical characteristics over recommended operating free-air temperature range (unless otherwise noted)**

PARAMETER	TEST CONDITIONS †	SN5430		SN7430		UNIT		
		MIN	TYP ‡	MAX	MIN		TYP ‡	MAX
$V_{IK}$	$V_{CC} = \text{MIN}, I_I = -12 \text{ mA}$			-1.5		-1.5	V	
$V_{OH}$	$V_{CC} = \text{MIN}, V_{IL} = 0.8 \text{ V}, I_{OH} = -0.4 \text{ mA}$	2.4	3.4		2.4	3.4	V	
$V_{OL}$	$V_{CC} = \text{MIN}, V_{IH} = 2 \text{ V}, I_{OL} = 16 \text{ mA}$		0.2	0.4		0.2	0.4	V
$I_I$	$V_{CC} = \text{MAX}, V_I = 5.5 \text{ V}$			1		1	mA	
$I_{IH}$	$V_{CC} = \text{MAX}, V_I = 2.4 \text{ V}$			40		40	µA	
$I_{IL}$	$V_{CC} = \text{MAX}, V_I = 0.4 \text{ V}$			-1.6		-1.6	mA	
$I_{OS} §$	$V_{CC} = \text{MAX}$	-20		-55	-18	-55	mA	
$I_{CCH}$	$V_{CC} = \text{MAX}, V_I = 0$		1	2		1	2	mA
$I_{CCL}$	$V_{CC} = \text{MAX}, V_I = 4.5 \text{ V}$		3	6		3	6	mA

† For conditions shown as MIN or MAX, use the appropriate value specified under recommended operating conditions.

‡ All typical values are at  $V_{CC} = 5 \text{ V}, T_A = 25^\circ\text{C}$ .

§ Not more than one output should be shorted at a time.

**switching characteristics,  $V_{CC} = 5 \text{ V}, T_A = 25^\circ\text{C}$  (see note 2)**

PARAMETER	FROM (INPUT)	TO (OUTPUT)	TEST CONDITIONS	MIN	TYP	MAX	UNIT
$t_{PLH}$	Any	Y	$R_L = 400 \Omega, C_L = 15 \text{ pF}$		13	22	ns
$t_{PHL}$					8	15	ns

NOTE 2: Load circuits and voltage waveforms are shown in Section 1.

**SN54LS30, SN74LS30**  
**8-INPUT POSITIVE-NAND GATES**

**absolute maximum ratings over operating free-air temperature range (unless otherwise noted)**

Supply voltage, $V_{CC}$ (see Note 1) .....	7 V
Input voltage .....	7 V
Operating free-air temperature range: SN54LS30 .....	-55°C to 125°C
SN74LS30 .....	0°C to 70°C
Storage temperature range .....	-65°C to 150°C

NOTE 1: Voltage values are with respect to network ground terminal.

**recommended operating conditions**

	SN54LS30			SN74LS30			UNIT
	MIN	NOM	MAX	MIN	NOM	MAX	
$V_{CC}$ Supply voltage	4.5	5	5.5	4.75	5	5.25	V
$V_{IH}$ High-level input voltage	2			2			V
$V_{IL}$ Low-level input voltage			0.7			0.8	V
$I_{OH}$ High-level output current			-0.4			-0.4	mA
$I_{OL}$ Low-level output current			4			8	mA
$T_A$ Operating free-air temperature	-55		125	0		70	°C

**electrical characteristics over recommended operating free-air temperature range (unless otherwise noted)**

PARAMETER	TEST CONDITIONS †	SN54LS30		SN74LS30		UNIT		
		MIN	TYP‡	MAX	MIN		TYP‡	MAX
$V_{IK}$	$V_{CC} = \text{MIN}, I_I = -18 \text{ mA}$			-1.5		-1.5	V	
$V_{OH}$	$V_{CC} = \text{MIN}, V_{IL} = \text{MAX}, I_{OH} = -0.4 \text{ mA}$	2.5	3.4	2.7	3.4		V	
$V_{OL}$	$V_{CC} = \text{MIN}, V_{IH} = 2 \text{ V}, I_{OL} = 4 \text{ mA}$		0.25	0.4		0.4	V	
	$V_{CC} = \text{MIN}, V_{IH} = 2 \text{ V}, I_{OL} = 8 \text{ mA}$				0.25	0.5		
$I_I$	$V_{CC} = \text{MAX}, V_I = 7 \text{ V}$		0.1			0.1	mA	
$I_{IH}$	$V_{CC} = \text{MAX}, V_I = 2.7 \text{ V}$		20			20	µA	
$I_{IL}$	$V_{CC} = \text{MAX}, V_I = 0.4 \text{ V}$		-0.4			-0.4	mA	
$I_{OS}§$	$V_{CC} = \text{MAX}$	-20		-100		-20	-100	mA
$I_{CCH}$	$V_{CC} = \text{MAX}, V_I = 0$		0.35	0.5		0.35	0.5	mA
$I_{CCL}$	$V_{CC} = \text{MAX}, V_I = 4.5 \text{ V}$		0.6	1.1		0.6	1.1	mA

† For conditions shown as MIN or MAX, use the appropriate value specified under recommended operating conditions.

‡ All typical values are at  $V_{CC} = 5 \text{ V}, T_A = 25^\circ\text{C}$

§ Not more than one output should be shorted at a time, and the duration of the short-circuit should not exceed one second.

**switching characteristics,  $V_{CC} = 5 \text{ V}, T_A = 25^\circ\text{C}$  (see note 2)**

PARAMETER	FROM (INPUT)	TO (OUTPUT)	TEST CONDITIONS	MIN	TYP	MAX	UNIT
$t_{PLH}$	Any	Y	$R_L = 2 \text{ k}\Omega, C_L = 15 \text{ pF}$		8	15	ns
$t_{PHL}$					13	20	ns

NOTE 2: Load circuits and voltage waveforms are shown in Section 1.

2  
TTL Devices

## SN54S30, SN74S30 8-INPUT POSITIVE-NAND GATES

### absolute maximum ratings over operating free-air temperature range (unless otherwise noted)

Supply voltage, $V_{CC}$ (see Note 1) .....	7 V
Input voltage .....	5.5 V
Operating free-air temperature range: SN54S30 .....	-55°C to 125°C
SN74S30 .....	0°C to 70°C
Storage temperature range .....	-65°C to 150°C

NOTE 1: Voltage values are with respect to network ground terminal.

### recommended operating conditions

	SN54S30			SN74S30			UNIT
	MIN	NOM	MAX	MIN	NOM	MAX	
$V_{CC}$ Supply voltage	4.5	5	5.5	4.75	5	5.25	V
$V_{IH}$ High-level input voltage	2			2			V
$V_{IL}$ Low-level input voltage			0.8			0.8	V
$I_{OH}$ High-level output current			-1			-1	mA
$I_{OL}$ Low-level output current			20			20	mA
$T_A$ Operating free-air temperature	-55		125	0		70	°C

### electrical characteristics over recommended operating free-air temperature range (unless otherwise noted)

PARAMETER	TEST CONDITIONS †	SN54S30			SN74S30			UNIT
		MIN	TYP‡	MAX	MIN	TYP‡	MAX	
$V_{IK}$	$V_{CC} = \text{MIN}$ , $I_I = -18 \text{ mA}$			-1.2			-1.2	V
$V_{OH}$	$V_{CC} = \text{MIN}$ , $V_{IL} = 0.8 \text{ V}$ , $I_{OH} = -1 \text{ mA}$	2.5	3.4		2.7	3.4		V
$V_{OL}$	$V_{CC} = \text{MIN}$ , $V_{IH} = 2 \text{ V}$ , $I_{OL} = 20 \text{ mA}$			0.5			0.5	V
$I_I$	$V_{CC} = \text{MAX}$ , $V_I = 5.5 \text{ V}$			1			1	mA
$I_{IH}$	$V_{CC} = \text{MAX}$ , $V_I = 2.7 \text{ V}$			50			50	µA
$I_{IL}$	$V_{CC} = \text{MAX}$ , $V_I = 0.5 \text{ V}$			-2			-2	mA
$I_{OS}§$	$V_{CC} = \text{MAX}$	-40		-100	-40		-100	mA
$I_{CCH}$	$V_{CC} = \text{MAX}$ , $V_I = 0$			3			3	mA
$I_{CCL}$	$V_{CC} = \text{MAX}$ , $V_I = 4.5 \text{ V}$			5.5			10	mA

† For conditions shown as MIN or MAX, use the appropriate value specified under recommended operating conditions.

‡ All typical values are at  $V_{CC} = 5 \text{ V}$ ,  $T_A = 25^\circ\text{C}$ .

§ Not more than one output should be shorted at a time, and the duration of the short-circuit should not exceed one second.

### switching characteristics, $V_{CC} = 5 \text{ V}$ , $T_A = 25^\circ\text{C}$ (see note 2)

PARAMETER	FROM (INPUT)	TO (OUTPUT)	TEST CONDITIONS	MIN	TYP	MAX	UNIT
$t_{PLH}$	Any	Y	$R_L = 280 \Omega$ , $C_L = 15 \text{ pF}$		4	6	ns
$t_{PHL}$					4.5	7	ns
$t_{PLH}$			$R_L = 280 \Omega$ , $C_L = 50 \text{ pF}$		5.5		ns
$t_{PHL}$					6.5		ns

NOTE 2: Load circuits and voltage waveforms are shown in Section 1.

2

TTL Devices

