

SN5406, SN5416, SN7406, SN7416 HEX INVERTER BUFFERS/DRIVERS WITH OPEN-COLLECTOR HIGH-VOLTAGE OUTPUTS

DECEMBER 1983—REVISED MARCH 1988

- Converts TTL Voltage Levels to MOS Levels
- High Sink-Current Capability
- Input Clamping Diodes Simplify System Design
- Open-Collector Driver for Indicator Lamps and Relays
- Inputs Fully Compatible with Most TTL Circuits

SN5406, SN5416 . . . J OR W PACKAGE
SN7406, SN7416 . . . N PACKAGE
(TOP VIEW)

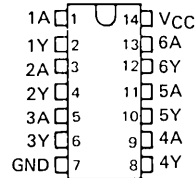

description

These monolithic TTL hex inverter buffers/drivers feature high-voltage open-collector outputs for interfacing with high-level circuits (such as MOS), or for driving high-current loads (such as lamps or relays), and are also characterized for use as inverter buffers for driving TTL inputs. The SN5406 and SN7406 have minimum breakdown voltages of 30 volts and the SN5416 and SN7416 have minimum breakdown voltages of 15 volts. The maximum sink current is 30 milliamperes for the SN5406 and SN5416, and 40 milliamperes for the SN7406 and SN7416.



logic symbol†

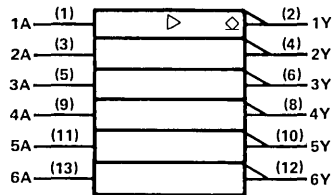

† This symbol is in accordance with ANSI/IEEE Std 91-1984 and IEC Publication 617-12.

logic diagram (positive logic)

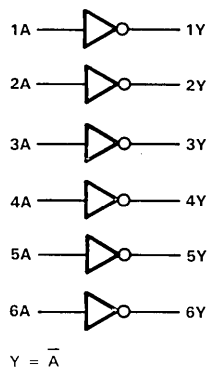

schematic

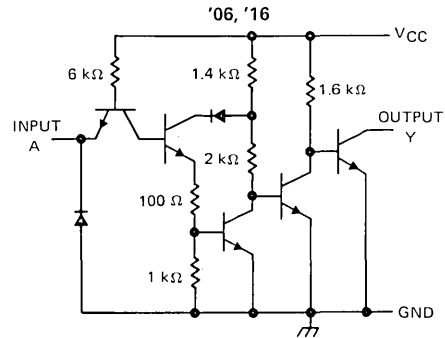

Resistor values shown are nominal.

TTL Devices

SN5406, SN5416, SN7406, SN7416
HEX INVERTER BUFFERS/DRIVERS WITH
OPEN-COLLECTOR HIGH-VOLTAGE OUTPUTS

absolute maximum ratings over operating free-air temperature range (unless otherwise noted)

Supply voltage, V_{CC} (see Note 1)	7 V
Input voltage (see Note 1)	5.5 V
Output voltage (see Notes 1 and 2): SN5406, SN7406 Circuits	30 V
SN5416, SN7416 Circuits	15 V
Operating free-air temperature range: SN5406, SN5416 Circuits	-55°C to 125°C
SN7406, SN7416 Circuits	0°C to 70°C
Storage temperature range	-65°C to 150°C

- NOTES: 1. Voltage values are with respect to network ground terminal.
2. This is the maximum voltage which should be applied to any output when it is in the off state.

recommended operating conditions

	SN5406 SN5416			SN7406 SN7416			UNIT
	MIN	NOM	MAX	MIN	NOM	MAX	
V_{CC} Supply voltage	4.5	5	5.5	4.75	5	5.25	V
V_{IH} High-level input voltage	2			2			V
V_{IL} Low-level input voltage	0.8			0.8			V
V_{OH} High-level output voltage	'06			30			V
	'16			15			
I_{OL} Low-level output current	30			40			mA
T_A Operating free-air temperature	-55		125	0		70	°C

electrical characteristics over recommended operating free-air temperature range (unless otherwise noted)

PARAMETER	TEST CONDITIONS†	SN5406 SN5416			SN7406 SN7416			UNIT
		MIN	TYP‡	MAX	MIN	TYP‡	MAX	
V_{IK}	$V_{CC} = \text{MIN}, I_I = -12 \text{ mA}$	-1.5			-1.5			V
I_{OH}	$V_{CC} = \text{MIN}, V_{IL} = 0.8 \text{ V}, V_{OH} = \S$	0.25			0.25			mA
V_{OL}	$V_{CC} = \text{MIN}, V_{IH} = 2 \text{ V}$	$I_{OL} = 16 \text{ mA}$			0.4			V
		$I_{OL} = ¶$			0.7			
I_I	$V_{CC} = \text{MAX}, V_I = 5.5 \text{ V}$	1			1			mA
I_{IH}	$V_{CC} = \text{MAX}, V_{IH} = 2.4 \text{ V}$	40			40			µA
I_{IL}	$V_{CC} = \text{MAX}, V_{IL} = 0.4 \text{ V}$	-1.6			-1.6			mA
I_{CCH}	$V_{CC} = \text{MAX}$	30		48	30		48	mA
I_{CCL}	$V_{CC} = \text{MAX}$	32		51	32		51	mA

- † For conditions shown as MIN or MAX, use the appropriate value specified under recommended operating conditions.
‡ All typical values are at $V_{CC} = 5 \text{ V}, T_A = 25^\circ\text{C}$.
§ $V_{OH} = 30 \text{ V}$ for '06 and 15 V for '16.
¶ $I_{OL} = 30 \text{ mA}$ for SN54' and 40 mA for SN74'.

switching characteristics, $V_{CC} = 5 \text{ V}, T_A = 25^\circ\text{C}$ (see note 3)

PARAMETER	FROM (INPUT)	TO (OUTPUT)	TEST CONDITIONS		MIN	TYP	MAX	UNIT
t_{PLH}	A	Y	$R_L = 110 \Omega$	$C_L = 15 \text{ pF}$	10		15	ns
t_{PHL}					15		23	ns

NOTE 3: Load circuits and voltage waveforms are shown in Section 1.

2

TTL Devices