

SILICON TRANSISTORS

2SC1505, 2SC1506, 2SC1507

NPN SILICON TRIPLE DIFFUSED TRANSISTORS

COLOR TV CHROMA AND SOUND OUTPUT AMPLIFIERS

DESCRIPTION

The 2SC1505, 2SC1506 and 2SC1507 are high voltage triple diffused silicon transistors. These transistors are designed for use in line-operated color TV chroma output circuits and sound output circuits.

Three types of different lead configuration are prepared for designer's convenience.

FEATURES

- Suitable for chroma output circuits and sound output circuits ($P_0=1.5W$) in line-operated color TV receivers.
- High voltage, high f_T and low C_{ob} .
- Three types of different lead configuration available.
 - 2SC1505 Standard type
 - 2SC1506 TO-66 replacement
 - 2SC1507 Upright mounting

ABSOLUTE MAXIMUM RATINGS ($T_a=25^\circ C$)

Collector to Base Voltage	V_{CBO}	300	V
Collector to Emitter Voltage	V_{CEO}	300	V
Emitter to Base Voltage	V_{EBO}	7.0	V
Collector Current	I_C	200	mA
Total Power Dissipation	$P_T(T_c=25^\circ C)$	15	W
Total Power Dissipation	$P_T(T_a=25^\circ C)$	1.2	W
Junction Temperature	T_j	150	$^\circ C$
Storage Temperature	T_{stg}	-55 to +150	$^\circ C$

ELECTRICAL CHARACTERISTICS ($T_a=25^\circ C$)

CHARACTERISTIC	SYMBOL	MIN.	TYP.	MAX.	UNIT	TEST CONDITIONS
Collector Cutoff Current	I_{CBO}			100	nA	$V_{CB}=200V, I_E=0$
Emitter Cutoff Current	I_{EBO}			100	nA	$V_{EB}=5.0V, I_C=0$
DC Current Gain	h_{FE}	40	80	200		$V_{CE}=10V, I_C=10mA$ *
Collector Saturation Voltage	$V_{CE(sat)}$			2.0	V	$I_C=50mA, I_B=5.0mA$ *
Gain Bandwidth Product	f_T	50	80		MHz	$V_{CE}=30V, I_E=-10mA$
Collector to Base Capacitance	C_{ob}			4.5	pF	$V_{CB}=50V, I_E=0, f=1.0MHz$

* Pulse test $PW \leq 350\mu s$, duty cycle $\leq 2.0\%$

h_{FE} classification / M: 40-80 L: 60-120 K: 100-200

PACKAGE DIMENSIONS (Unit:mm)

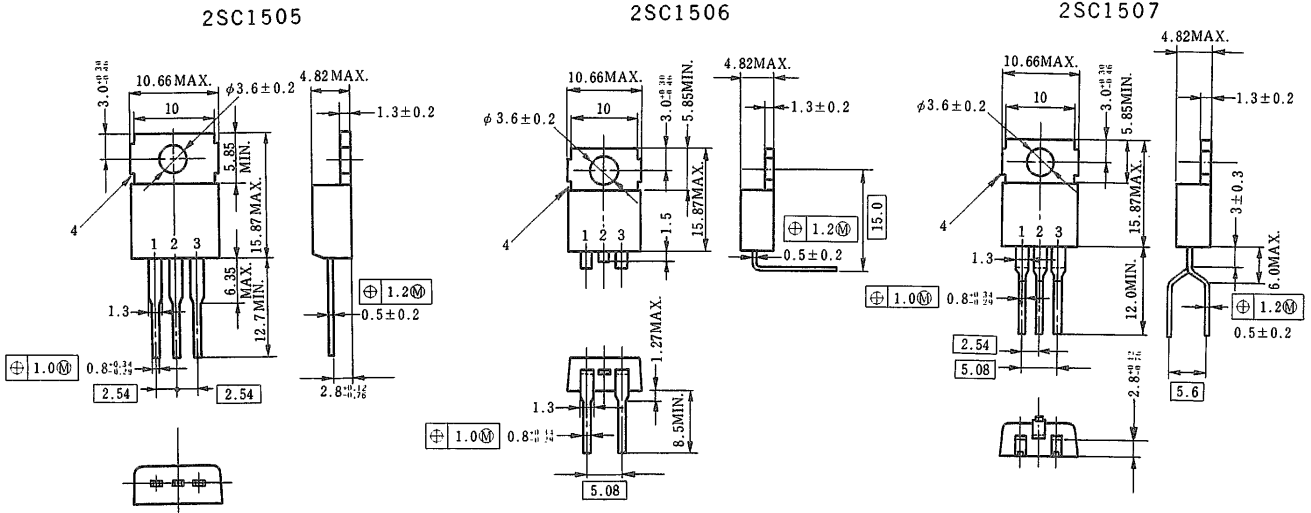

MOUNTING HOLE LAYOUT DIMENSIONS

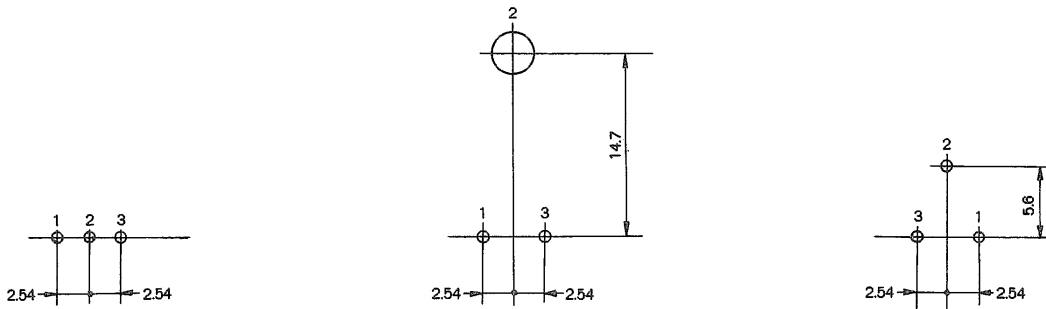

LEAD CONNECTION

- 1. Base EIAJ :SC-46
- 2. Collector(Fin) JEDEC:TO-220AB
- 3. Emitter IEC :-
- 4. Fin

As the clearance between collector and Base, Emitter is narrow, care should be taken at high voltage use.

- 1. Base EIAJ :SC-45
- 2. - JEDEC:TO-220AA
- 3. Emitter IEC :-
- 4. Collector(Fin)

As the collector lead is cut, solder lug is used instead of it.

- 1. Base EIAJ :-
- 2. Collector(Fin) JEDEC:-
- 3. Emitter IEC :-
- 4. Fin

Convenient in case of free-air use.

SUGGESTED MOUNTING METHODS

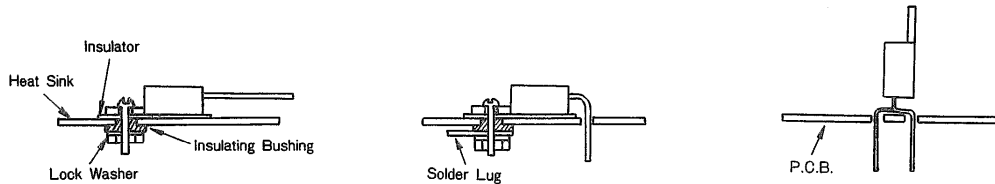

POWER-TEMPERATURE DERATING CURVES

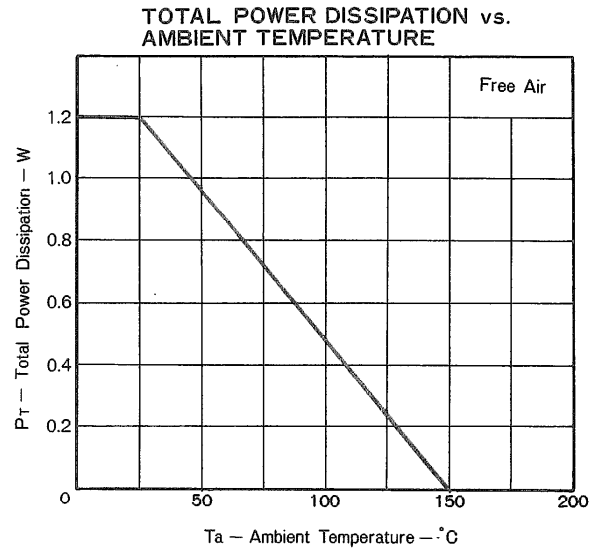
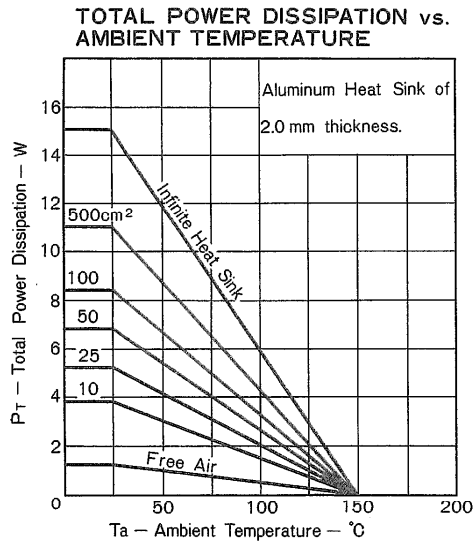

TYPICAL CHARACTERISTICS (Ta=25°C)

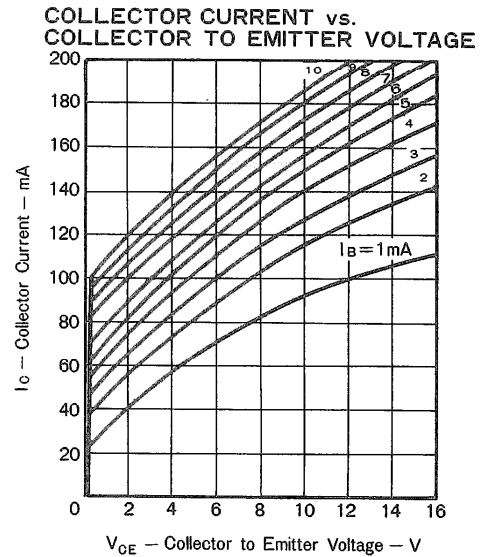
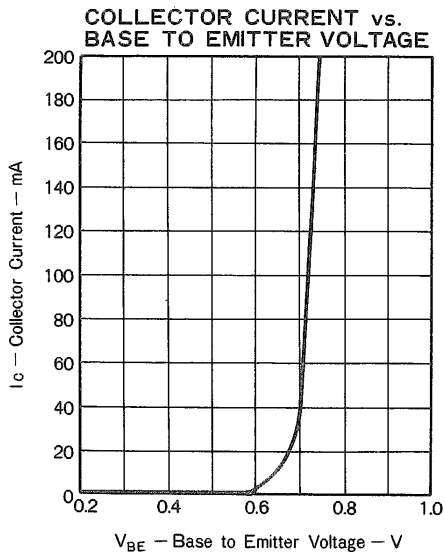

COLLECTOR CURRENT vs. COLLECTOR TO EMITTER VOLTAGE

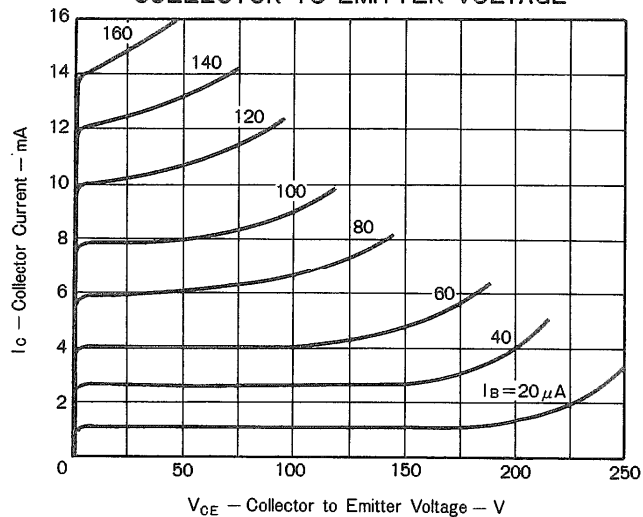

DC CURRENT GAIN vs. COLLECTOR CURRENT

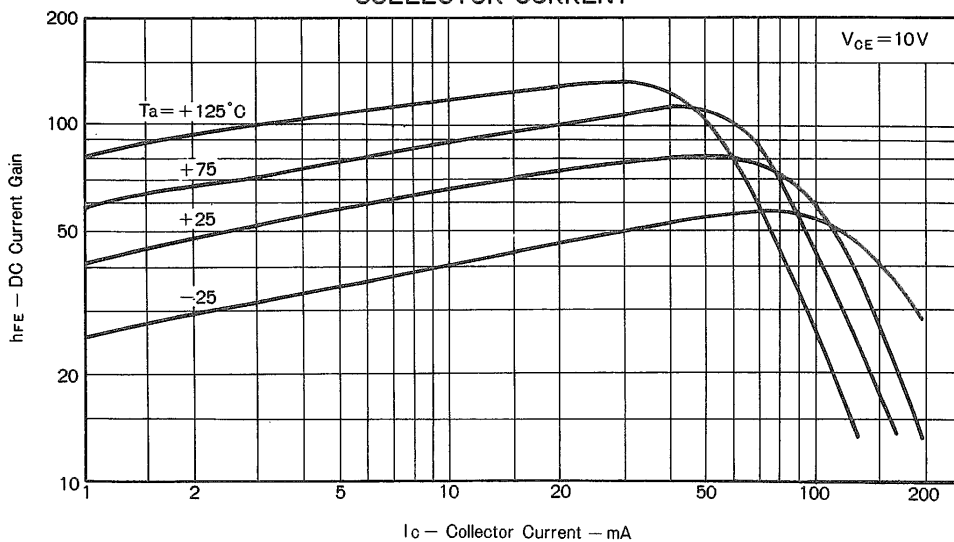

BASE AND COLLECTOR SATURATION VOLTAGE vs. COLLECTOR CURRENT

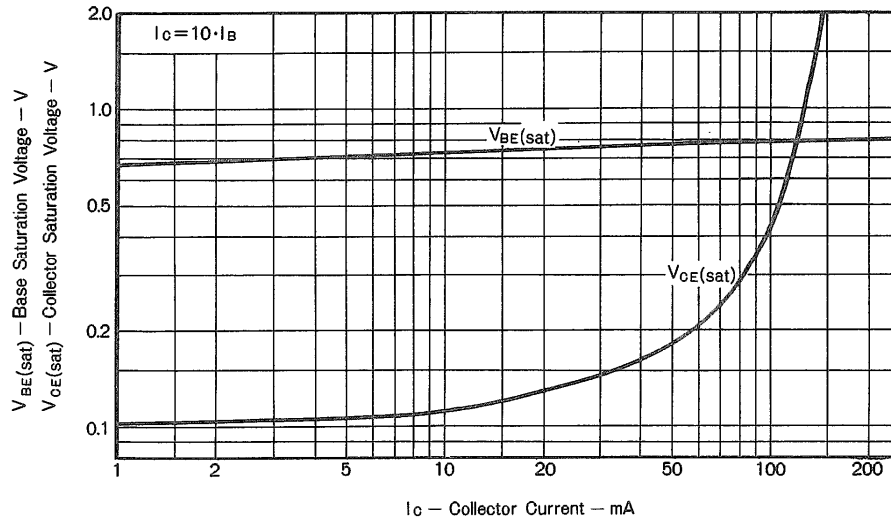

OUTPUT CAPACITANCE vs. COLLECTOR TO BASE VOLTAGE

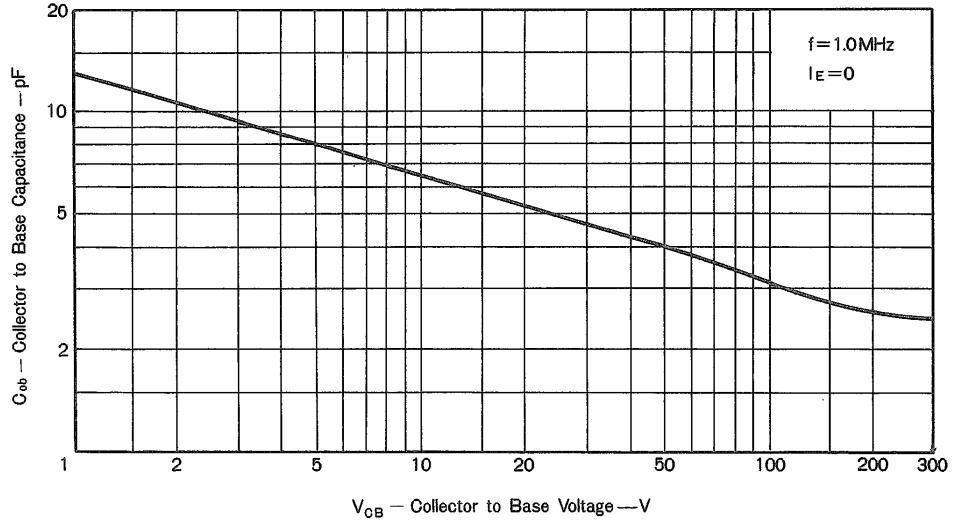

GAIN BANDWIDTH PRODUCT vs.
EMITTER CURRENT

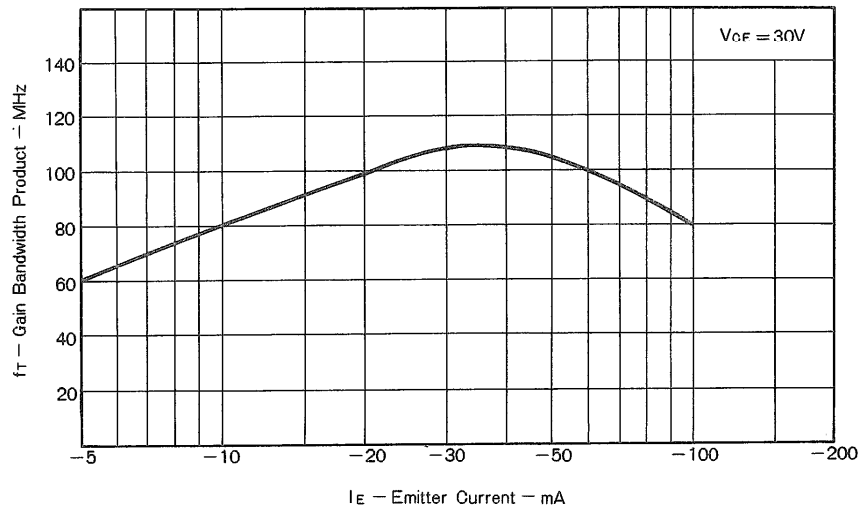

Nippon Electric Co., Ltd.

NEC Building, 33-1, Shiba Gochome, Minato-ku, Tokyo 108, Japan
 Tel.: Tokyo 454-1111
 Telex Address: NECTOK A J22686
 Cable Address: MICROPHONE TOKYO

TC-1010B
 APR.-20-79K
 Printed in Japan